



Owner's Manual

VSHCDC Systems
VSACDCR Systems

ADVENTURE IS ALWAYS ON THE LINE!



VSHCDC Systems



VSACDCR Systems

This manual is also available online

940 NW 1st St, Fort Lauderdale, FL 33311 USA
954.462.5570 FAX 954.462.6115

www.BrowniesMarineGroup.com



CONGRATULATIONS ON YOUR PURCHASE OF A BROWNIE'S SYSTEM

You now have in your possession the finest, most reliable, surface supplied breathing air system available. The operation is designed with your safety and convenience in mind, and by carefully reading this brief manual you can be assured of many hours of trouble-free enjoyment.



**READ ALL SAFETY RULES AND OPERATING INSTRUCTIONS
CONTAINED IN THIS MANUAL AND FOLLOW THEM WITH EACH USE
OF THIS PRODUCT.**

MANUAL SAFETY NOTICES



Important instructions concerning the endangerment of personnel, technical safety or operator safety will be specially emphasized in this manual by placing the information in the following types of safety notices.

 **DANGER** 



DANGER indicates an imminently hazardous situation which, if not avoided, will result in death or serious injury.
This is limited to the most extreme situations.

 **WARNING** 

WARNING indicates a potentially hazardous situation which, if not avoided, could result in death or injury.

 **CAUTION** 

CAUTION indicates a potentially hazardous situation which, if not avoided, may result in minor or moderate injury.
It may also be used to alert against unsafe practices.

 **NOTE** 

NOTE advise of technical requirements that require particular attention by the operator or the maintenance technician for proper maintenance and utilization of the equipment.

REGISTER YOUR PRODUCT ONLINE
Go to www.BrowniesMarineGroup.com to
register your product. Registration will allow us to
keep you informed about important issues and news
about your system.

Table of Contents

Specifications	3
VSHCDC Compressor	4
VSACDCR Compressor	5
Standard System Component List	6
Medical Clearance/Potential Risks	6
Online Training	13
Setting Up	14
Using the 12/24vdc twist-lock connector	14
Connecting to a single 12vdc or 24vdc battery	15
Connecting two 12vdc batteries to create a 24vdc source	16
Connecting to a 115vac power source	16
Hoses	18
Drop Weight Cummerbelt™	19
Egressor™ Package	20
Troubleshooting Guide	21
Post Dive	22
Warranty	22
Brownie's Hookah Regulator	23
Compressor Rebuild Instructions	24
Compressor Exploded View	25
Use of Equipment in the Bahamas Islands	26

SPECIFICATIONS

	VSHCDC	VSACDCR
Compressor	Oil-less, single head, direct drive	Oil-less, single head, direct drive
Motor	.75 HP sealed DC motor with sealed switch	.75 HP sealed DC motor with sealed switch
Run Speed	Variable Speed 1450-2600 rpm	Variable Speed 1450-2600 rpm
Amp Draw	12vdc: 26.7a avg, 30a max 24vdc: 19.8a avg, 25a max 120vac: not applicable	12vdc: 26.7a avg, 30a max 24vdc: 19.8a avg, 25a max 120vac: 9.0a avg, 15a max
Air Delivery (24vdc electric service)	3.5 cfm @ 50psi; 6 cfm @ 0psi 99 lpm @ 345 kPa; 170 lpm @ 0 kPa	3.5 cfm @ 50psi; 6 cfm @ 0psi 99 lpm @ 345 kPa; 170 lpm @ 0 kPa
Dimensions: Compressor Case (L x W x H)	Hand carry case 15 x 12.25 x 9.75 inches 38 x 31 x 25 cm	Wheeled case with telescoping handle 24 x 16 x 10 inches 61 x 40.6 x 25.4 cm
Weight: Compressor Case	26 pounds 11.8 kg	46 pounds 20.9 kg





WHEN YOU RECEIVE YOUR NEW COMPRESSOR SYSTEM

1. Inspect the contents to be sure everything is included.
2. Contact your dealer within 5 days of receipt should your equipment be damaged or missing.
3. Read and understand the information in this and other supplied manuals before operating.

	VSHCDC-1B	VSHCDC-1X	VSHCDC-1XE	VSACDCR-2B	VSACDCR-2X	VSACDCR-2XE
Compressor in case	Y	Y	Y	Y	Y	Y
DC electric lead w/twist-lock connector (male)	Y	Y	Y	Y	Y	Y
Female twist-lock socket with alligator type battery connections	1	1	1	1	1	1
Battery terminal connector pigtail, + to -, alligator type battery connections	1	1	1	1	1	1
AC power supply w/5ft lead	N/A	N/A	N/A	Integrated	Integrated	Integrated
5ft heat transfer hose w/filter	1	1	1	1	1	1
Downline	40 ft	40 ft	40 ft	40 ft	40 ft	40 ft
QRS Y divider	-	-	-	1	1	1
20ft diver hose	1	1	1	2	2	2
Brownie hookah regulator	1	1	1	2	2	2
Drop weight cummerbelt	-	1	1	-	2	2
Basic towbelt	1	-	-	2	-	-
Brownie's mesh gearbag	1	1	1	1	1	1
Manual	Y	Y	Y	Y	Y	Y
Online Hookah training certificates	1	1	1	2	2	2
Egressor™ mini scuba system: Tank sleeve for cummerbelt, 6 cuft cylinder with valve, Egressor regulator, Regulator retention necklace	-	-	1	-	-	2
Spare parts: QRS fittings (2 male, 2 female) O-rings, Filter screen kit	Y	Y	Y	Y	Y	Y

⚠ DANGER ⚠

Before using this system or engaging in any underwater activities you must ensure: 1) you are in good physical health 2) you are in good mental health 3) you have been properly trained and 4) you know the potential risks of diving.

MEDICAL CLEARANCE/POTENTIAL RISKS

Diving can be one of the most exciting and rewarding activities you will ever experience. However, like most exciting activities, there are rules and procedures you must follow. Proper training is crucial to minimize risk and maximize enjoyment. Breathing in an underwater environment can be dangerous, or even deadly, if you don't know the rules or if you chose to ignore them.

Please refer to the *RSTC Medical Statement and Guidelines for Recreational Scuba Divers Physical Examination* included with this manual. You should complete all portions of the medical statement including the Divers Medical Questionnaire for each user of the system. You may photocopy the form as needed. Please keep this information on file for future reference and to review with your doctor or any professional diving instructor.

The purpose of the *Divers Medical Questionnaire* is to find out if you should be examined by your doctor before participating in recreational diver training. A positive response to a question does not necessarily disqualify you from diving. A positive response means that there is a pre-existing condition that may affect your safety while diving and you must seek the advice of your physician prior to engaging in dive activities. Please answer the following questions on your past or present medical history with a YES or NO. If you are not sure, answer YES. If any of these items apply to you or you are not sure, we must request that you consult with a physician prior to participating in SSA (surface supplied air) diving. Take the *RSTC Medical Statement and Guidelines for Recreational Scuba Diver's Physical Examination* to your physician.

Temporary Risk Conditions

- Back pain

HEMATOLOGICAL

Abnormalities resulting in altered rheological properties may theoretically increase the risk of decompression sickness. Bleeding disorders could worsen the effects of otic or sinus barotrauma, and exacerbate the injury associated with inner ear or spinal cord decompression sickness. Spontaneous bleeding into the joints (e.g.: in hemophilia) may be difficult to distinguish from decompression illness.

Relative Risk Conditions

- Sickle Cell Disease
- Polycythemia Vera
- Leukemia
- Hemophilia/Impaired Coagulation

METABOLIC AND ENDOCRINOLOGICAL

With the exception of diabetes mellitus, states of altered hormonal or metabolic function should be assessed according to their impact on the individual's ability to tolerate the moderate exercise requirement and environmental stress of sport diving. Obesity may predispose the individual to decompression sickness, can impair exercise tolerance and is a risk factor for coronary artery disease.

Relative Risk Conditions

- Hormonal Excess or Deficiency
- Obesity
- Renal Insufficiency

Severe Risk Conditions

The potentially rapid change in level of consciousness associated with hypoglycemia in diabetics on insulin therapy or certain oral hypoglycemic medications can result in drowning. Diving is therefore generally contraindicated, unless associated with a specialized program that addresses these issues.

Pregnancy: The effect of venous emboli formed during decompression on the fetus has not been thoroughly investigated. Diving is therefore not recommended during any stage of pregnancy or for women actively seeking to become pregnant.

BEHAVIORAL HEALTH

Behavioral: The diver's mental capacity and emotional make-up are important to safe diving. The student diver must have sufficient learning abilities to grasp information presented to him by his instructors, be able to safely plan and execute his own dives and react to changes around him in the underwater environment. The student's motivation to learn and his ability to deal with potentially dangerous situations are also crucial to safe scuba diving.

Relative Risk Conditions

- Developmental delay
- History of drug or alcohol abuse
- History of previous psychotic episodes
- Use of psychotropic medications

Severe Risk Conditions

- Inappropriate motivation to dive – solely to please spouse, partner or family member, to prove oneself in the face of personal fears
- Claustrophobia and agoraphobia

- Active psychosis
- History of untreated panic disorder
- Drug or alcohol abuse

OTOLARYNGOLOGICAL

Equalisation of pressure must take place during ascent and descent between ambient water pressure and the external auditory canal, middle ear and paranasal sinuses. Failure of this to occur results at least in pain and in the worst case rupture of the occluded space with disabling and possible lethal consequences.

The inner ear is fluid filled and therefore noncompressible. The flexible interfaces between the middle and inner ear, the round and oval windows are, however, subject to pressure changes. Previously ruptured but healed round or oval window membranes are at increased risk of rupture due to failure to equalise pressure or due to marked overpressurisation during vigorous or explosive Valsalva manoeuvres.

The larynx and pharynx must be free of an obstruction to airflow. The laryngeal and epiglottic structure must function normally to prevent aspiration.

Mandibular and maxillary function must be capable of allowing the patient to hold a scuba mouthpiece. Individuals who have had mid-face fractures may be prone to barotrauma and rupture of the air filled cavities involved.

Relative Risk Conditions

- Recurrent otitis externa
- Significant obstruction of external auditory canal
- History of significant cold injury to pinna
- Eustachian tube dysfunction
- Recurrent otitis media or sinusitis
- History of TM perforation
- History of tympanoplasty
- History of mastoidectomy
- Significant conductive or sensorineural hearing impairment
- Facial nerve paralysis not associated with barotrauma
- Full prosthodontic devices
- History of mid-face fracture
- Unhealed oral surgery sites
- History of head and/or neck therapeutic radiation
- History of temperomandibular joint dysfunction
- History of round window rupture

Severe Risk Conditions

- Monomeric TM
- Open TM perforation
- Tube myringotomy
- History of stapedectomy
- History of ossicular chain surgery
- History of inner ear surgery
- Facial nerve paralysis secondary to barotrauma
- Inner ear disease other than presbycusis
- Uncorrected upper airway obstruction
- Laryngectomy or status post partial laryngectomy
- Tracheostomy
- Uncorrected laryngocele
- History of vestibular decompression sickness

1. Bennett, P. & Elliott, D (eds.)(1993). *The Physiology and Medicine of Diving*. 4th Ed., W.B. Saunders Company Ltd., London, England.

- History of Coronary Artery Bypass Grafting (CABG)
- Percutaneous Balloon Angioplasty (PCTA) or Coronary Artery Disease (CAD)
- History of Myocardial Infarction
- Congestive Heart Failure
- Hypertension
- History of dysrhythmias requiring medication for suppression
- Valvular Regurgitation

Pacemakers

The pathologic process that necessitated should be addressed regarding the diver's fitness to dive. In those instances where the problem necessitating pacing does not preclude diving, will the diver be able to meet the performance criteria?

* NOTE: Pacemakers must be certified by the manufacturer as able to withstand the pressure changes involved in recreational diving.

Severe Risks

Venous emboli, commonly produced during decompression, may cross major intracardiac right-to-left shunts and enter the cerebral or spinal cord circulations causing neurological decompression illness. Hypertrophic cardiomyopathy and valvular stenosis may lead to the sudden onset of unconsciousness during exercise.

PULMONARY

Any process or lesion that impedes airflow from the lungs places the diver at risk for pulmonary overinflation with alveolar rupture and the possibility of cerebral air embolization. Many interstitial diseases predispose to spontaneous pneumothorax: Asthma (reactive airway disease), Chronic Obstructive Pulmonary Disease (COPD), cystic or cavitating lung diseases may all cause air trapping. The 1996 Undersea and Hyperbaric Medical Society (UHMS) consensus on diving and asthma indicates that for the risk of pulmonary barotrauma and decompression illness to be acceptably low, the asthmatic diver should be asymptomatic and have normal spirometry before and after an exercise test. Inhalation challenge tests (e.g.: using histamine, hypertonic saline or methacholine) are not sufficiently standardized to be interpreted in the context of scuba diving.

A pneumothorax that occurs or reoccurs while diving may be catastrophic. As the diver ascends, air trapped in the cavity expands and could produce a tension pneumothorax.

In addition to the risk of pulmonary barotrauma, respiratory disease due to either structural disorders of the lung or chest wall or neuromuscular disease may impair exercise performance. Structural disorders of the chest or abdominal wall (e.g.: prune belly), or neuromuscular disorders, may impair cough, which could be life threatening if water is aspirated. Respiratory limitation due to disease is compounded by the combined effects of immersion (causing a restrictive deficit) and the increase in gas density, which increases in proportion to the ambient pressure (causing increased airway resistance). Formal exercise testing may be helpful.

Relative Risk Conditions

- History of Asthma or Reactive Airway Disease (RAD)*
- History of Exercise Induced Bronchospasm (EIB)*
- History of solid, cystic or cavitating lesion*
- Pneumothorax secondary to:
 - Thoracic Surgery
 - Trauma or Pleural Penetration*
 - Previous Overinflation Injury*
- Obesity

- History of Immersion Pulmonary Edema Restrictive Disease*
- Interstitial lung disease: May increase the risk of pneumothorax

* Spirometry should be normal before and after exercise

Active Reactive Airway Disease, Active Asthma, Exercise Induced Bronchospasm, Chronic Obstructive Pulmonary Disease or history of same with abnormal PFTs or a positive exercise challenge are concerns for diving.

Severe Risk Conditions

- History of spontaneous pneumothorax. Individuals who have experienced spontaneous pneumothorax should avoid diving, even after a surgical procedure designed to prevent recurrence (such as pleurodesis). Surgical procedures either do not correct the underlying lung abnormality (e.g.: pleurodesis, apical pleurectomy) or may not totally correct it (e.g.: resection of blebs or bullae).
- Impaired exercise performance due to respiratory disease.

GASTROINTESTINAL

Temporary Risks

As with other organ systems and disease states, a process which chronically debilitates the diver may impair exercise performance. Additionally, dive activities may take place in areas remote from medical care. The possibility of acute recurrences of disability or lethal symptoms must be considered.

Temporary Risk Conditions

- Peptic Ulcer Disease associated with pyloric obstruction or severe reflux
- Unrepaired hernias of the abdominal wall large enough to contain bowel within the hernia sac could incarcerate.

Relative Risk Conditions

- Inflammatory Bowel Disease
- Functional Bowel Disorders

Severe Risks

Altered anatomical relationships secondary to surgery or malformations that lead to gas trapping may cause serious problems. Gas trapped in a hollow viscous expands as the divers surfaces and can lead to rupture or, in the case of the upper GI tract, emesis. Emesis underwater may lead to drowning.

Severe Risk Conditions

- Gastric outlet obstruction of a degree sufficient to produce recurrent vomiting
- Chronic or recurrent small bowel obstruction
- Severe gastroesophageal reflux
- Achalasia
- Paraesophageal Hernia

ORTHOPAEDIC

Relative impairment of mobility, particularly in a boat or ashore with equipment weighing up to 18 kgs/40 pounds must be assessed. Orthopaedic conditions of a degree sufficient to impair exercise performance may increase the risk.

Relative Risk Conditions

- Amputation
- Scoliosis must also assess impact on respiratory function and exercise performance.
- Aseptic Necrosis possible risk of progression due to effects of decompression (evaluate the underlying medical cause of decompression may accelerate/escalate the progression).

Guidelines for Recreational Scuba Diver's Physical Examination

Instructions to the Physician: *Printed with permission from UHMS

Recreational **SCUBA** (Self-Contained Underwater Breathing Apparatus) can provide recreational divers with an enjoyable sport safer than many other activities. The risk of diving is increased by certain physical conditions, which the relationship to diving may not be readily obvious. Thus, it is important to screen divers for such conditions.

The **RECREATIONAL SCUBA DIVER'S PHYSICAL EXAMINATION** focuses on conditions that may put a diver at increased risk for decompression sickness, pulmonary overinflation syndrome with subsequent arterial gas embolization and other conditions such as loss of consciousness, which could lead to drowning. Additionally, the diver must be able to withstand some degree of cold stress, the physiological effects of immersion and the optical effects of water and have sufficient physical and mental reserves to deal with possible emergencies.

The history, review of systems and physical examination should include as a minimum the points listed below. The list of conditions that might adversely affect the diver is not all-inclusive, but contains the most commonly encountered medical problems. The brief introductions should serve as an alert to the nature of the risk posed by each medical problem.

The potential diver and his or her physician must weigh the pleasures to be had by diving against an increased risk of death or injury due to the individual's medical condition. As with any recreational activity, there are no data for diving enabling the calculation of an accurate mathematical probability of injury. Experience and physiological principles only permit a qualitative assessment of relative risk.

For the purposes of this document, **Severe Risk** implies that an individual is believed to be at substantially elevated risk of decompression sickness, pulmonary or otic barotrauma or altered consciousness with subsequent drowning, compared with the general population. The consultants involved in drafting this document would generally discourage a student with such medical problems from diving. **Relative Risk** refers to a moderate increase in risk, which in some instances may be acceptable. To make a decision as to whether diving is contraindicated for this category of medical problems, physicians must base their judgement on an assessment of the individual patient. Some medical problems which may preclude diving are **temporary** in nature or responsive to treatment, allowing the student to dive safely after they have resolved.

Diagnostic studies and specialty consultations should be obtained as indicated to determine the diver's status. A list of references is included to aid in clarifying issues that arise. Physicians and other medical professionals of the Divers Alert Network (DAN) associated with Duke University Health System are available for consultation by phone +1 919 684 2948 during normal business hours. For emergency calls, 24 hours 7 days a week, call +1 919 684 8111 or +1 919 684 4DAN (collect). Related organizations exist in other parts of the world – DAN Europe in Italy +39 039 605 7858, DAN S.E.A.P. in Australia +61 3 9886 9166 and Divers Emergency Service (DES) in Australia +61 8 8212 9242, DAN Japan +81 33590 6501 and DAN Southern Africa +27 11 242 0380. There are also a number of informative websites offering similar advice.

NEUROLOGICAL

Neurological abnormalities affecting a diver's ability to perform exercise should be assessed according to the degree of compromise. Some diving physicians feel that conditions in which there can be a waxing and waning of neurological symptoms and signs, such as migraine or demyelinating disease, contraindicate diving because an exacerbation or attack of the preexisting disease (e.g.: a migraine with aura) may be difficult to distinguish from neurological decompression sickness. A history of head

injury resulting in unconsciousness should be evaluated for risk of seizure.

Relative Risk Conditions

- **Complicated Migraine Headaches whose symptoms or severity impair motor or cognitive function, neurologic manifestations**
- **History of Head Injury with sequelae other than seizure**
- **Herniated Nucleus Pulposus**
- **Intracranial Tumor or Aneurysm**
- **Peripheral Neuropathy**
- **Multiple Sclerosis**
- **Trigeminal Neuralgia**
- **History of spinal cord or brain injury**

Temporary Risk Condition

History of cerebral gas embolism without residual where pulmonary air trapping has been excluded and for which there is a satisfactory explanation and some reason to believe that the probability of recurrence is low.

Severe Risk Conditions

Any abnormalities where there is a significant probability of unconsciousness, hence putting the diver at increased risk of drowning. Divers with spinal cord or brain abnormalities where perfusion is impaired may be at increased risk of decompression sickness.

Some conditions are as follows:

- **History of seizures other than childhood febrile seizures**
- **History of Transient Ischemic Attack (TIA) or Cerebrovascular Accident (CVA)**
- **History of Serious (Central Nervous System, Cerebral or Inner Ear) Decompression Sickness with residual deficits**

CARDIOVASCULAR SYSTEMS

Relative Risk Conditions

The diagnoses listed below potentially render the diver unable to meet the exertional performance requirements likely to be encountered in recreational diving. These conditions may lead the diver to experience cardiac ischemia and its consequences. Formalized stress testing is encouraged if there is any doubt regarding physical performance capability. The suggested minimum criteria for stress testing in such cases is at least 13 METS.* Failure to meet the exercise criteria would be of significant concern. Conditioning and retesting may make later qualification possible. Immersion in water causes a redistribution of blood from the periphery into the central compartment, an effect that is greatest in cold water. The marked increase in cardiac preload during immersion can precipitate pulmonary edema in patients with impaired left ventricular function or significant valvular disease. The effects of immersion can mostly be gauged by an assessment of the diver's performance while swimming on the surface. A large proportion of scuba diving deaths in North America are due to coronary artery disease. Before being approved to scuba dive, individuals older than 40 years are recommended to undergo risk assessment for coronary artery disease. Formal exercise testing may be needed to assess the risk.

* METS is a term used to describe the metabolic cost. The MET at rest is one, two METS is two times the resting level, three METS is three times the resting level, and so on. The resting energy cost (net oxygen requirement) is thus standardized. (Exercise Physiology; Clark, Prentice Hall, 1975.)

Relative Risk Conditions

STUDENT

Please print legibly.

Name _____ Birth Date _____ Age _____
First Initial Last Day/Month/Year

Mailing Address _____

City _____ State/Province/Region _____

Country _____ Zip/Postal Code _____

Home Phone () _____ Business Phone () _____

Email _____ FAX _____

Name and address of your family physician

Physician _____ Clinic/Hospital _____

Address _____

Date of last physical examination _____

Name of examiner _____ Clinic/Hospital _____

Address _____

Phone () _____ Email _____

Were you ever required to have a physical for diving? Yes No If so, when? _____

PHYSICIAN

This person applying for training or is presently certified to engage in scuba (self-contained underwater breathing apparatus) diving. Your opinion of the applicant's medical fitness for scuba diving is requested. There are guidelines attached for your information and reference.

Physician's Impression

I find no medical conditions that I consider incompatible with diving.

I am unable to recommend this individual for diving.

Remarks _____

Physician's Signature or Legal Representative of Medical Practitioner Date _____
Day/Month/Year

Physician _____ Clinic/Hospital _____

Address _____

Phone () _____ Email _____

BIBLIOGRAPHY/REFERENCE

- Bove, A., & Davis, J. (1990). *Diving Medicine*. 2nd Edition, W.B. Saunders Company, Philadelphia, PA.
- Davis, J., & Bove, A. (1986). "Medical Examination of Sport Scuba Divers, Medical Seminars, Inc.," San Antonio, TX
- Dembert, M. & Keith, J. (1986). "Evaluating the Potential Pediatric Scuba Diver." *AJDC*, Vol. 140, November.
- Edmonds, C., Lowry, C., & Pennefether, J. (1992) .3rd ed., *Diving and Subaquatic Medicine*. Butterworth & Heineman Ltd., Oxford, England.
- Elliott, D. (Ed) (1994). "Medical Assessment of Fitness to Dive." Proceedings of an International Conference at the Edinburgh Conference Centre, Biomedical Seminars, Surry, England.
- "Fitness to Dive," Proceedings of the 34th Underwater & Hyperbaric Medical Society Workshop (1987) UHMS Publication Number 70(WS-FD) Bethesda, MD.
- Neuman, T. & Bove, A. (1994). "Asthma and Diving." *Ann. Allergy*, Vol. 73, October, O'Conner & Kelsen.
- Shilling, C. & Carlston, D. & Mathias, R. (eds) (1984). *The Physician's Guide to Diving Medicine*. Plenum Press, New York, NY.
- Undersea and Hyperbaric Medical Society (UHMS) www.UHMS.org
- Divers Alert Network (DAN) United States, 6 West Colony Place, Durham, NC www.DiversAlertNetwork.org
- Divers Alert Network Europe, P.O. Box 64026 Roseto, Italy, telephone non-emergency line: weekdays office hours +39-085-893-0333, emergency line 24 hours: +39-039-605-7858
- Divers Alert Network S.E.A.P., P. O. Box 384, Ashburton, Australia, telephone 61-3-9886-9166
- Divers Emergency Service, Australia, www.rah.sa.gov.au/hyperbaric, telephone 61-8-8212-9242
- South Pacific Underwater Medicine Society (SPUMS), P.O. Box 190, Red Hill South, Victoria, Australia, www.spums.org.au
- European Underwater and Baromedical Society, www.eubs.org

ENDORRSERS

Paul A. Thombs, M.D., Medical Director
Hyperbaric Medical Center
St. Luke's Hospital, Denver, CO, USA

Peter Bennett, Ph.D., D.Sc.
Professor, Anesthesiology
Duke University Medical Center
Durham, NC, USA
pbennett@dan.duke.edu

Richard E. Moon, M.D., F.A.C.P., F.C.C.P.
Departments of Anesthesiology and Pulmonary
Medicine
Duke University Medical Center
Durham, NC, USA

Roy A. Myers, M.D.
MIEMS
Baltimore, MD, USA

William Clem, M.D., Hyperbaric Consultant
Division Presbyterian/St. Luke's Medical Center
Denver, CO, USA

John M. Alexander, M.D.
Northridge Hospital
Los Angeles, CA, USA

Des Gorman, B.Sc., M.B.Ch.B., F.A.C.O.M.,
F.A.F.O.M., Ph.D.
Professor of Medicine
University of Auckland, Auckland, NZ
d.gorman@auckland.ac.nz

Alf O. Brubakk, M.D., Ph.D.
Norwegian University of Science and Technology
Trondheim, Norway
alfb@medisin.ntnu.no

Alessandro Marroni, M.D.
Director, DAN Europe
Roseto, Italy
Hugh Greer, M.D.
Santa Barbara, CA, USA
hdgblgfp@aol.com

Christopher J. Acott, M.B.B.S., Dip. D.H.M.,
F.A.N.Z.C.A.
Physician in Charge, Diving Medicine
Royal Adelaide Hospital
Adelaide, SA 5000, Australia

Chris Edge, M.A., Ph.D., M.B.B.S., A.F.O.M.
Nuffield Department of Anaesthetics
Radcliffe Infirmary
Oxford, United Kingdom
cjedge@diver.demon.co.uk

Richard Vann, Ph.D.
Duke University Medical Center
Durham, NC, USA

Keith Van Meter, M.D., F.A.C.E.P.
Assistant Clinical Professor of Surgery
Tulane University School of Medicine
New Orleans, LA, USA

Robert W. Goldmann, M.D.
St. Luke's Hospital
Milwaukee, WI, USA

Paul G. Linaweaver, M.D., F.A.C.P.
Santa Barbara Medical Clinic
Undersea Medical Specialist
Santa Barbara, CA, USA

James Vorosmarti, M.D.
6 Orchard Way South
Rockville, MD, USA

Tom S. Neuman, M.D., F.A.C.P., F.A.C.P.M.
Associate Director, Emergency Medical Services
Professor of Medicine and Surgery
University of California at San Diego
San Diego, CA, USA

Yoshihiro Mano, M.D.
Professor
Tokyo Medical and Dental University
Tokyo, Japan
y.mano.ns@tmd.ac.jp

Simon Mitchell, MB.ChB., DipDHM, Ph.D.
Wesley Centre for Hyperbaric Medicine
Medical Director
Sandford Jackson Bldg., 30 Chasely Street
Auchenflower, QLD 4066 Australia
smitchell@wesley.com.au

Jan Risberg, M.D., Ph.D.
NUI, Norway

Karen B. Van Hoesen, M.D.
Associate Clinical Professor
UCSD Diving Medicine Center
University of California at San Diego
San Diego, CA, USA

Edmond Kay, M.D., F.A.A.F.P.
Dive Physician & Asst. Clinical Prof. of Family Medicine
University of Washington
Seattle, WA, USA
ekay@u.washington.edu

Christopher W. Dueker, TWS, M.D.
Atherton, CA, USA
chrisduek@aol.com

Charles E. Lehner, Ph.D.
Department of Surgical Sciences
University of Wisconsin
Madison, WI, USA
celehner@facstaff.wisc.edu

Undersea & Hyperbaric Medical Society
10531 Metropolitan Avenue
Kensington, MD 20895, USA

Diver's Alert Network (DAN)
6 West Colony Place
Durham, NC 27705



WARNING



IMPROPER USE OF ANY UNDERWATER DIVING EQUIPMENT CAN RESULT IN SERIOUS INJURY OR DEATH. DO NOT DIVE WITHOUT PROPER TRAINING.

ONLINE TRAINING

In the interest of sharing the most accurate and up-to-date information on accepted diving practices, Brownie's Third Lung has teamed up with Scuba-Training.net to provide free online dive training with the purchase of each Surface Supplied Hookah System.

The program is an interactive, web-based learning course designed to teach you how to properly and safely use your hookah system. It is broken down into 7 modules each with specific Knowledge Requirements and Objectives.

The course utilizes a variety of written explanations, illustrations, photographs and streaming video to clearly convey each subject. Brownie's makes it easy for students of all ages, including children, to enjoy learning.

Each chapter concludes with a multiple choice quiz to test your understanding and comprehension of the topics covered. Incorrect answers are automatically reviewed and retested. Once you have successfully completed the quiz for that module, you can move on to the next module. After all chapters and quizzes have been completed there is a final comprehensive exam. The final exam follows the same format as the quizzes and may be retaken until it is successfully completed.

TO BEGIN ONLINE TRAINING

1. Launch your browser window (Internet Explorer, Netscape, etc.).
2. Go to www.scuba-training.net.
3. Locate the "sign-up code" (found on the hookah training certificate that came with your purchase) and enter it. (Example pictured below).
4. You will be asked to create an account choosing a "user name" (usually email address) and password. You will also be asked to enter pertinent information to create an account, such as address and telephone number.
5. There will be a medical questionnaire that must be filled out before beginning the chapters. Answering yes to any question will require a consultation with a physician prior to participating in the in-water training phase.

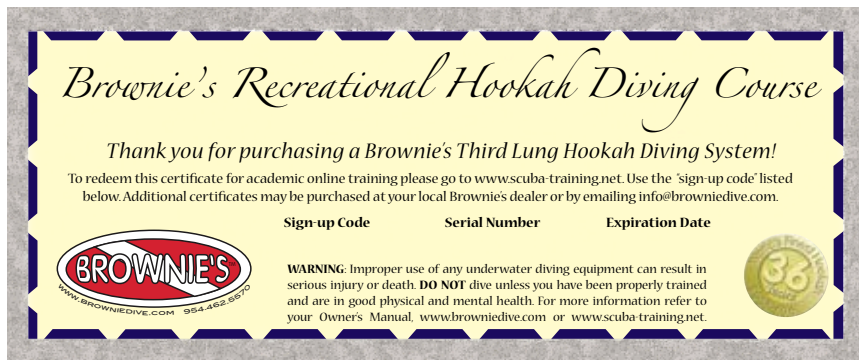

AFTER THE ONLINE COURSE IS COMPLETED

It is time to visit your local dive store for the in-water training phase.

The online course will provide academic knowledge. To complete your training you'll need to practice that knowledge in a controlled environment before venturing into open water. The course website, www.scuba-training.net, includes a list of affiliated independent scuba instructors and professional dive stores by geographic region. You should enroll in an in-water skills course with a professional scuba instructor to review your academic knowledge and practice your water skills. Your instructor will review with you the topics covered in the online course and evaluate your comprehension of the course content. Next, they will arrange a series of dives in a controlled environment (usually a pool) to practice breathing through a regulator and other water skills. He or she will share techniques to improve your efficiency and comfort in the water. By working closely with your instructor, you will become a better (and safer) diver.



WARNING



Your Third Lung is designed for shallow water, unobstructed diving and should never be used in enclosed areas, such as caves, shipwrecks or ledge overhangs.



WARNING



DO NOT POUR OIL INTO COMPRESSOR. THIS WILL CONTAMINATE THE COMPRESSOR AND RUIN IT FOR AIR BREATHING. BREATHING FROM A COMPRESSOR THAT HAS HAD OIL MISTAKENLY ADDED MAY RESULT IN SERIOUS INJURY. DO NOT SPRAY CORROSION X OR ANY PETROLEUM BASED PRODUCT ON, IN, OR AROUND THE COMPRESSOR.



WARNING



Never operate the equipment in an environment where toxic fumes are present such as near running outboard engines, exposed chemicals or fuel spills.

SETTING UP

1. Select a location with fresh, clean air. The compressor will pump the air from the immediate area through the hoses to the diver (s).



NOTE



Suitable for operation in a maximum surrounding air temperature of 104°F (40°C).



WARNING



The VSHCDC and VSACDCR compressors are designed to be used in a dry environment. Do not use an electric compressor in areas that will be subject to direct water exposure (rain, spray, splashing or other water sources).

The VSHCDC and VSACDCR compressors will operate when connected to either 12vdc or 24vdc power.

Air Delivery:

12vdc: 1 cfm @ 30psi (1 diver @ 45ft, 2 @ 20ft)

24vdc: 3 cfm @ 45psi (2 divers @ 65ft)

The VSACDCR compressor (only) has an integrated power supply to convert 110vac electric service to 24vdc power for the compressor. While using this configuration, the compressor will perform as if connected to a 24vdc power source. Details for this configuration follow in Step 2 below.

2. Make connection to a suitable power supply.

a. Compressor power cord.

The power cord for the VSHCDC and VSACDCR compressors terminate with a twist-lock connector, commonly used to prevent accidental disengagement of the electrical connection during use. Insert the connector into a mating female twist-lock socket that is supplying **12vdc or 24vdc** power.





WARNING



If you are unsure of the electric power supplied by a connection, test the circuit with an electric meter prior to use. If you are unable to perform the test, seek the assistance of a professional electrician.
Do not allow the electrical leads to come into contact with compressor during operation. Damage may occur.



NOTE



A female twist-lock connector is supplied with the system that can be installed in your boat or other suitable location. Installation should follow all local electric codes. If you are unable to perform the installation of the female twist-lock socket, seek the assistance of a professional electrician.

b. Connecting to a single 12vdc or 24vdc battery.



Photo 1

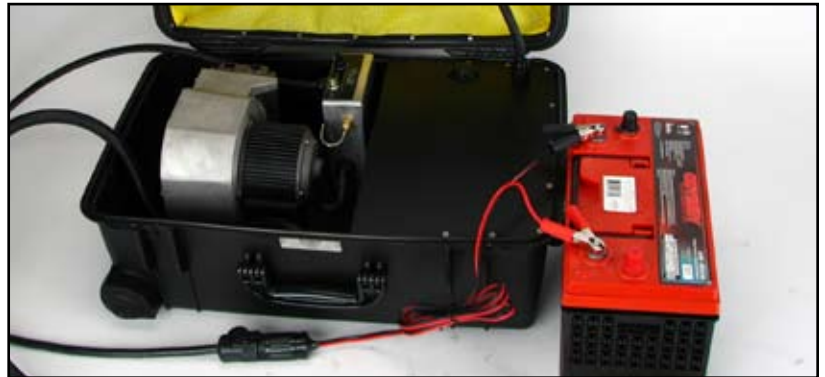

Photo 2

The female twist-lock connector supplied with the compressor includes 2 leads with alligator type clips for connecting to the post terminals of a battery. (photo 1)

- Make sure the compressor power switch is in the OFF position.
- Install the female twist-lock connector onto the male twist-lock connector at the end of the compressor power cord.
- Attach the black (-) clip to the negative (-) terminal post of a 12vdc or 24vdc battery. (photo 2)
- Attach the red (+) clip to the positive (+) terminal post of the same battery.



WARNING



An electric spark may occur when connecting the clips to the battery terminals. DO NOT perform this procedure in the presence of any potentially combustible fumes or materials.

Connect only to a free-standing battery that has no other leads attached to its terminals.
Do not allow the electrical leads to come into contact with compressor during operation. Damage may occur.

c. Connecting two 12vdc batteries to create a 24vdc source.

The female twist-lock connector supplied with the compressor includes 2 leads with alligator type clips for connecting to the post terminals of a battery. (photo 3)

- Make sure the compressor power switch is in the OFF position.
- Install the female twist-lock connector onto the male twist-lock connector at the end of the compressor power cord.
- Attach the black (-) clip to the negative (-) terminal post of a 12vdc battery. (photo 4)
- Attach the red (+) clip of the battery terminal connector pigtail to the positive (+) terminal post of the same battery.
- Attach the black (-) clip of the battery terminal connector pigtail to the negative (-) terminal of the second battery.
- Attach the red (+) clip to the positive (+) terminal post of the second battery.



Photo 3



Photo 4

⚠ WARNING ⚠

An electric spark may occur when connecting the clips to the battery terminals. DO NOT perform this procedure in the presence of any potentially combustible fumes or materials.
Connect only to free-standing batteries that have no other leads attached to their terminals. Damage to the batteries and/or other equipment attached may occur.
Do not allow the electrical leads to come into contact with compressor during operation. Damage may occur.

d. Connecting to 110vac power source. (VSACDCR model only)

The VSACDCR compressor has an integrated power supply to convert 110vac electric service to 24vdc power for the compressor.

- Make sure the compressor power switch is in the OFF position.
 - Install the male twist-lock connector into the female twist-lock socket on the deck of compressor. (photo 5)
- Twist the connector to engage and verify the connection is secure.
- Insert the electric plug into a GFI protected wall socket providing consistent 110-120vac electric power.



Photo 5



Photo 6

⚠ WARNING ⚠

Do not allow the electrical leads to come into contact with compressor during operation. Damage may occur.

3. Secure the compressor to avoid an unexpected disconnection from the power source, and to avoid pulling the compressor into the water while diving.



WARNING



The compressor case lid must be in the fully open position during operation. Operating the compressor while the case lid is partially closed may cause damage.

4. **Check the inline particle filter** at the end of the black heat transfer hose.
 - a. Unscrew the 2 knurled container parts to reveal the screen assembly.
 - b. Gently rock the screen until it drops out of the container.
 - c. Inspect the screen. It should be clean and free of debris. The screen can be cleaned by gently scrubbing with a clean toothbrush and rinsed with fresh, warm water. Clean or replace as necessary.
 - d. Reassemble by inserting the domed area of the screen toward the compressor.

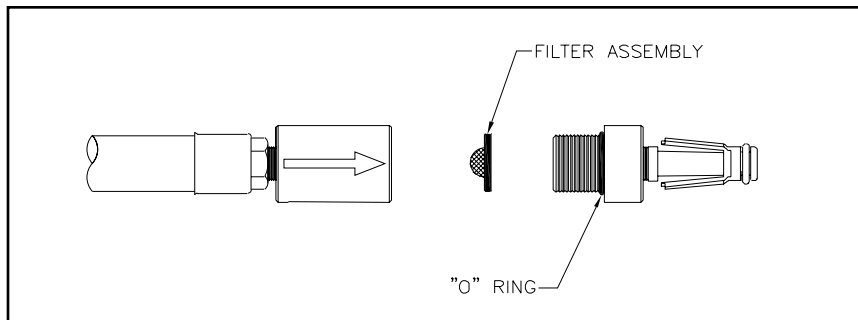

5. **Turn the compressor ON** to verify the output volume and pressure. Turn the compressor OFF.
6. **Connect the appropriate hose sections** in the following order.
 Single diver configuration: downline, 20ft diver hose, regulator & belt.
 Multiple diver configuration: common downline, Y-divider(s), 20ft diver hose (s), regulator(s) & belt(s).
 (See HOSES for additional information on the QRS connect/disconnect procedure.)

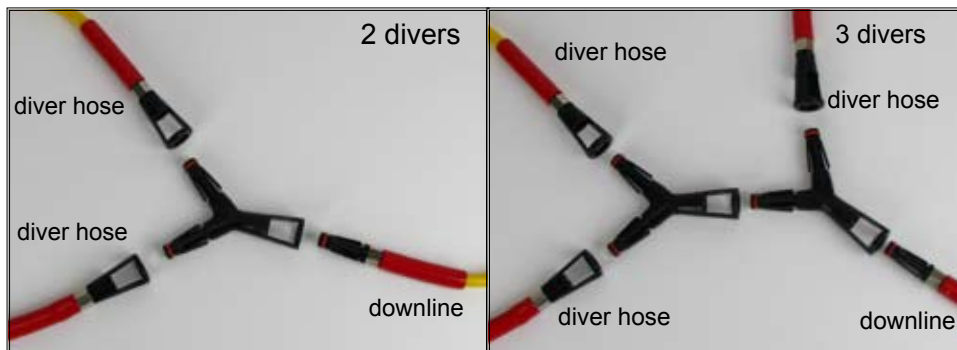

7. **Turn the compressor ON.** The Variable Speed technology will allow the compressor to run until the hose set is pressurized. When the hose(s) reach full pressure, the compressor speed will decrease and eventually stop. Check air delivery from the 2nd stage regulators by depressing the purge mechanism and by breathing from the regulators.



WARNING



Sudden bursts of energy might use up more air volume than the compressor can supply. This will result in restrictive breathing. If you encounter this, simply SLOW DOWN your breathing or refrain from exerting great amounts of energy until your respiration rate becomes normalized. Excitement, activity level, current flow, depth and experience level of divers will dictate your dive.

HOSES

Your Brownie's hookah system features our proprietary Quick Release Swivel (QRS) connectors, allowing you to engage or disengage hoses instantly, securely and without tools.

To engage the QRS hose ends:

1. Inspect the o-ring on the male fitting for any damage or foreign matter (hair, sand, etc). Clean and lightly lubricate with silicone grease as needed.
2. Insert the male fitting into the female fitting. Push together until you hear an audible "click", which indicates the fittings are correctly engaged.

To disengage the QRS hose ends:

1. Rotate the connection until the "wings" of the male fitting are visible in the "windows" of the female fitting.
2. While holding one hose end in each hand, squeeze the "wings" of the male fitting together and simultaneously pull the hose ends apart.



The QRS fittings are exclusive to Brownie's Third Lung and provide the following advantages:

- The plastic material is extremely durable and will provide years of reliable service. It is impervious to UV or ozone degradation.
- The fittings are much lighter than metal hoses ends. They will not hurt your feet or boat deck if dropped.
- The connection provides an audible "click" to confirm it is properly engaged, and it requires 2 hands to disengage.
- In the unlikely event that a fitting fails, a replacement can be installed on the hose end without special crimping or clamps.



Tips for use:

Coiled hoses will tend to remain coiled. To reduce the coiling effect, allow the hoses to warm in sunlight. Lay the hoses as straight as possible on the boat deck, pool deck, grassy area, or any other suitable location.

When stowing, larger loops have less coil effect than smaller, tighter loops.

Avoid allowing water, sand or other contaminants to enter the hoses. The easiest way to avoid intrusion is to engage the male and female fittings onto each other prior to rinsing or stowing the hose.

If something should enter the hose, follow these steps:

1. Shake as much material out of the hose as possible.
2. You can soak the hose in FRESH WATER ONLY to dissolve or dislodge any materials.
3. Force FRESH WATER ONLY through the hose.
4. Force clean fresh air through the hose.
5. When fully dry, engage the male and female QRS fittings to seal the ends prior to storage.

HOW TO ADJUST THE DROP WEIGHT CUMMERBELT:

1. Unclip the front buckle
2. Undo the Velcro underneath the buckle
3. Lay the belt flat open. Unzip the sleeve located on the back of the belt. You will see that there is a piece of elastic with the Velcro adjustments on both sides. The belt should be adjusted evenly on both sides so the front buckle is centered across the mid-section. Simply undo the Velcro and re-adjust them to fit the waist of the diver. (*For extremely small waist divers: You can switch the ends of the belt from opposite stainless steel loops to the loops that are next to each other. Bottom belt configuration will reduce belt size by approximately 3 inches.) Zip the sleeve back up.
4. Unclip the buckles that hold the drop weight pockets in place. Each pocket can hold up to 10 lbs. of weight. We recommend using soft lead shot weights rather than hard weights as they conform better to the shape of the pocket. Undo the Velcro and distribute the weight evenly into each pocket, then re-Velcro.
5. Reinsert the pockets matching the bend in the pocket to the bend in the belt itself, and reconnect the buckles.



HOW TO USE THE DROP WEIGHT CUMMERBELT WITH AN EGRESSOR PACKAGE (XE Packages):

1. Follow above steps 1-5.
2. Then unzip the sleeve that came with the Cummerbelt, and put aside. You will no longer need this sleeve unless there are times that you choose to dive without the Egressor scuba system.



3. Zip new sleeve onto the belt with the Brownie's logo facing upright.
4. Mount the regulator onto the tank and insert the cylinder with the valve pointing outward. Secure the cylinder in place using the elastic loop around the tank neck.
5. Open the tank valve completely.
6. The mouthpiece has a bungee necklace attached so the regulator may hang easily around the neck for quick retrieval in an out of air situation.



TROUBLESHOOTING GUIDE

Condition	Possible Cause	Solution
Compressor will not turn ON	<p>Insufficient power supply</p> <p>Circuit protector activated</p> <p>AC power interruption. (VSACDCR only)</p> <p>Motor or compressor locked or frozen</p>	<p>Connect the compressor to fully charged batteries.</p> <p>Depress the protector to reset. If the condition recurs, verify the incoming power is adequate to support the compressor operation.</p> <p>Reset circuit breaker and/or GFI when present.</p> <p>Service required. Contact Brownie's for technical assistance.</p>
Compressor speed slows, but will not stop, even when no air is being consumed through the second stage regulator.	Air leak	<p>Inspect hose connections and regulators for possible leaks.</p> <p>Service as necessary.</p>
Insufficient air.	<p>Debris in inline filter.</p> <p>Too many divers for the depth attempted.</p> <p>Diminishing battery power.</p>	<p>Clean or replace screen assembly.</p> <p>Ascend to shallower depth.</p> <p>Fully recharge battery before diving again.</p>
Water in 2nd stage regulator	<p>Diver in "head down" orientation</p> <p>Inverted exhaust valve.</p> <p>Leak in 2nd stage. (Mouthpiece, diaphragm, exhaust valve, o-rings)</p>	<p>Change orientation while diving to normal "head up – chin down" position.</p> <p>Manually reseal the exhaust valve.</p> <p>Have regulator serviced by a qualified technician.</p>
Diver headache, nausea, dizziness	Exhaust or other contaminants in the air around the compressor	<p>Stop diving immediately and move the compressor to a location with a clean, fresh air supply.</p> <p>If the condition persists, seek medical attention.</p>
Any strange noises or erratic behavior in the compressor.	<p>Water intrusion.</p> <p>Wear or failure of a mechanical component.</p> <p>Loss of lubrication.</p>	<p>Have unit inspected and serviced by a qualified technician</p>



CAUTION



Do not turn the compressor OFF until all divers are safely out of the water.

POST DIVE

1. When all divers are safely out of the water, turn the compressor OFF.
2. Rinse hoses, regulators and belts with fresh water and allow to dry.
Hose ends can be engaged on each other to prevent water or contaminants from entering hose.
(See the HOSE section for additional instructions to clear debris from the hose.)
3. Do not depress the purge mechanism of the 2nd stage regulators while soaking or rinsing.
4. Allow the gear to dry, then stow neatly in the mesh gear bag or other suitable container.
5. Allow the compressor to cool before closing the lid. The compressor will get HOT during operation.
It is safe to close the lid when the compressor is warm (not hot) to touch.
6. Keep the storage case clean inside. Remove any debris and wipe the case interior surfaces with a cloth dampened with fresh water only.
Do not use commercial cleaners with fumes that may be ingested by the compressor.
7. Coil and stow the black compressor hose and electric cord inside the case before closing and latching the lid.

WARRANTY

Brownie's Third Lung products are warranted to be free of defects in materials and workmanship for a period of one year from the date of retail purchase. A copy of retail purchase receipt, showing model and serial numbers is required to verify warranty eligibility. This warranty is limited and subject to the restrictions listed below.

Brownie's will repair, replace or refund valid warranty claims, at our discretion. Brownie's shall not be liable for any special, incidental or consequential damages beyond the wholesale purchase price.

Please fill out and return enclosed Warranty Registration Form along with a copy of dated retail purchase receipt to register your warranty.

What is not covered

Inspection, service and/or labor charges will be paid by the retail consumer.

Some parts are subject to wear, even under normal or minimal use. All components should be inspected for wear on a regular basis. Replacement of worn items constitutes normal maintenance and is the responsibility of the owner.

This warranty does not cover damage resulting from the introduction of water, gas, oil or other contaminants, normal wear, improper use, improper maintenance, neglect of care, alteration, or unauthorized repair.

All repairs made, not covered under the terms of this warranty, will be made at the owner's expense.

RETURN GOODS POLICY AND INSTRUCTIONS

To return merchandise to Brownie's for service or credit:

1. Call our sales department to obtain a RMA number and shipping destination (954.462.5570)
2. Pack authorized items in sturdy container
3. Boldly print the RMA number on the package exterior
4. Include: a note detailing the situation, a copy of original purchase receipt showing model number, serial number, date and place of purchase
5. Ship package, freight prepaid, to the designated location

Unauthorized returns, returns shipped freight collect and returns missing RMA numbers may be refused or subject to additional inspection/processing fees.

Items returned for credit must be in new condition (at our discretion) and will be subject to a 15% restocking fee (30% for custom orders.)

BROWNIE'S BOTTOM-MOUNT REGULATOR

We've changed the placement of the hose to follow a more natural path!

While scuba hoses are typically routed from the top of the tank around the diver's shoulder, hookah regulator hoses are attached to the diver's waist. By moving the hose to the bottom of the regulator the hose can lay cleanly next to the diver's body thereby creating a more efficient, streamlined profile in the water and reducing the chance of snagging the hose on objects nearby.

Additionally, there is a substantial reduction in the sideways torque placed on the second stage from the hose resulting in reduced jaw effort to grip the regulator.



NO:	P/N NO	DESCRIPTION
1	A-02-010-11	LONG MOUTHPIECE-P5
2	A-02-010-12	NYLON TIE
3	A-02-008-03	MAIN HOUSING
4	A-02-008-04	EXHAUST TEE
5	A-02-008-05	EXHAUST VALVE
6	B-02-010-01	DIAPHRAGM
7	A-02-010-10	DIAPHRAGM WASHER
8	A-02-010-04	COVER RING PLASTIC/ALUMINUM(C-02-010-07)
9	A-02-010-05	COVER BUTTON
10	C-02-010-06	NUT SCREW 5-40
11	P-02-008-01	STAINLESS SPACER
12	S-02-008-01	LEVER ARM
13	C-02-008-01	ADJUST TUBE
14	D-02-008-01	SPRING
15	C-02-008-02	POPPET
16	A-02-008-01	LP SEAT
17	O-EKM-15MX-1-5	O-RING-N70
18	A-02-010-06	ORIFICE
19	O-AS568-010	O-RING-N70
20	O-AS568-012	O-RING-N70
28	C-02-008-09	ADJUST SCREW

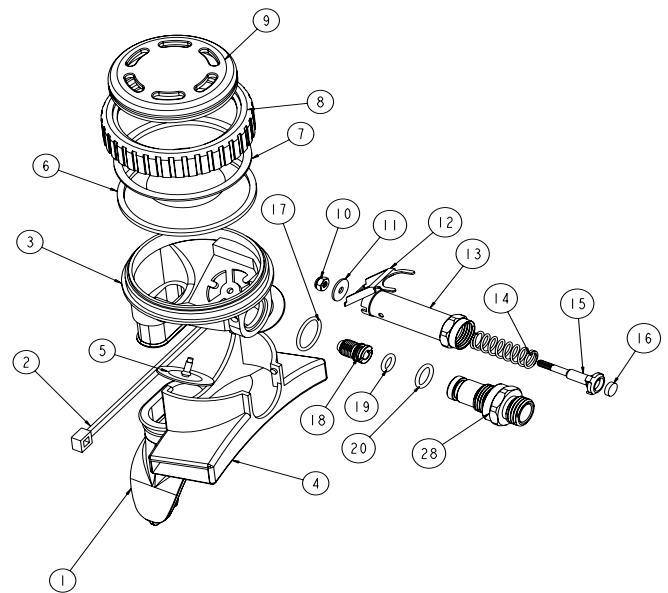

REBUILD KIT INSTRUCTIONS

Tools needed to perform this service:

Medium (6-8") Adjustable Wrench

1/8 Allen wrench

#2 Phillips screwdriver

#3 Phillips screwdriver

1/2" and 5/16" nut driver or socket wrench

11/16", 1/2" and 5/16" wrench

Rubber Hammer

Note: This procedure will deal with the disassembly of the compressor head and installation of the components contained in the compressor head rebuild kit.

You must have free access to exterior surfaces of the compressor assembly to perform this service. You will need to remove the motor/compressor assembly from the protective case to gain adequate access to perform this service.

Remove any straps from the pan that may inhibit the removal of motor/compressor assembly.

There are 4 bolts that hold the motor onto the pan or case. Locate and hold each of the 4 bolts at the base of the motor using a 1/2" wrench, and loosen the corresponding Nylock nuts on the underneath of the pan using a 1/2" socket wrench. Set bolts and nuts aside until reassembly.

1. Using a 11/16" wrench, remove the black Heat Hose (item 23) from the compressor head.
2. Using a 5/16" socket, remove the screws (item 8), lock washers (item 9) and flat washers (item 10) from front cover (item 7). Remove cover.
3. Using 5/16" socket, remove the screws (item 17), lockwashers (item 9) and flat washers* (item 10, 4 sets) from the compressor head. Remove compressor head (item 15).
4. Separate compressor head (item 15) from valve plate assembly (item 12).
5. Pull out piston sleeve (item 11a).

Inspect rod and bearing assembly. The piston rod should pivot freely on the bearing. There should be no play perpendicular to the bearing.

6. Using a #2 Phillips screwdriver, remove screws (items 12b), valve restraints (items 12c) and flapper valves (items 12d) from plate.
7. Using a #3 screwdriver, remove screw (item 11b) from center of piston head. Remove cap (item 11c) and cup (item 11d).
8. Install new piston sleeve (item 11a) over bare piston head onto piston rod.
9. Slowly pull engine start cord, or manually turn fan (item 4) to position piston at maximum extension.
10. Place piston cap (item 11c) into center of new piston cup (item 11d).
11. Install new retainer screw (item 11b) through cap (item 11c) and cup (item 11d), into threaded center of piston head. Start screwing retainer screw into piston head. With rubber hammer tap cup & cap into sleeve then tighten screw.
12. Install new flapper valves (items 12d) located under the valve restraints (items 12c) onto valve plate (item 12e), carefully matching valves with setting posts.
13. Install new o-ring (item 12f) and gasket (item 12a) making sure each is fully seated in its appropriate groove.
14. Hold completed valve plate assembly (item 12) gasket side up. Place head (item 15) onto valve plate assembly (item 12), lining up posts.
15. Place lockwashers (item 9) and flat washers (item 10) onto screws (item 17) and install into corner holes of the head assembly. Install two flat washers* (item 10) onto the screw threads protruding through the head assembly. (Washers will be between head assembly and housing.) Align screws with holes in housing and begin threading by hand. Tighten using 5/16" socket.
16. Using adjustable wrench, remove relief valve (item 13). Install new relief valve and tighten until snug.
17. Align front cover (item 7) with holes in housing. Install screws (item 8), lockwashers (item 9) and flat washers (item 10). Tighten using a 5/16" socket.
18. Place motor/compressor assembly in pan or dish. Secure with same bolts and nuts as disassembled. Replace any straps that were removed.

* If flat washers are present during disassembly, they must be replaced during reassembly. Current production models do not have flat washers located between compressor head and housing.

COMPRESSOR EXPLODED VIEW

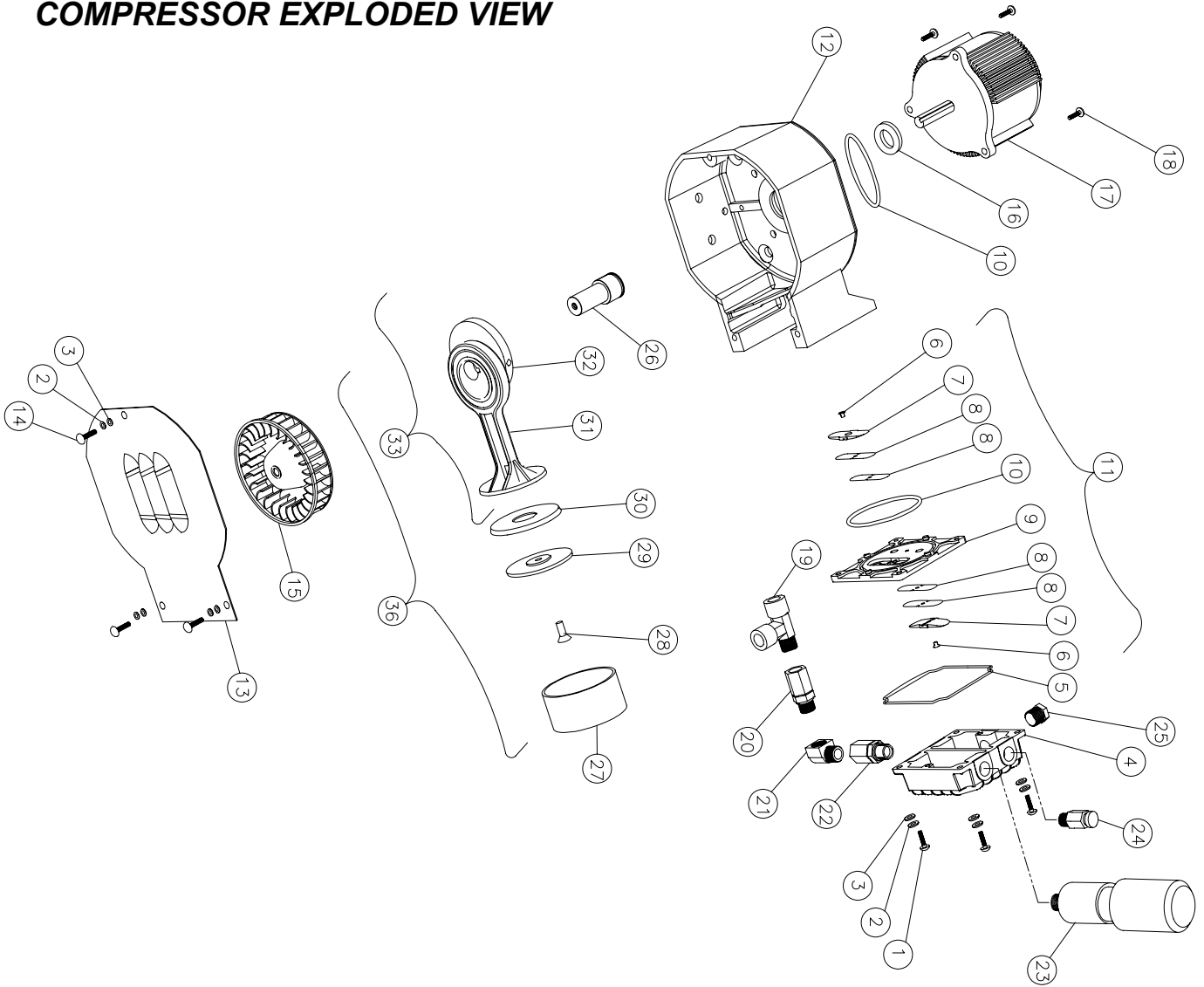

NO.	PART NUMBER	DESCRIPTION
1	HMSSS10C-1	SCREW, 10-24, 1 INCH
2	WML2210	LOCK WASHER
3	AN960C10L	WASHER
4	AC-HEAD	HEAD SINGLE
5*	AC1-2-17	GASKET, VALVE HEAD SPECIAL
6*	AC1-2-20	SCREW 6-32 X 3/8
7	AC1-2-19	VALVE RESTRAINT
8*	AC1-2-18	VALVE FLAPPER
9	AC1-2-13	VALVE PLATE
10*	AC-VPO	O-RING
11	AC-VPA	VALVE PLATE ASSEMBLY
12	AC1-VS HOUSING	VS1 HOUSING
13	AC2-TSS	COVER TWIN SS VENTED
14	HMSSS10C.3/8	SCREW, 10-24, 3/8
15	638656	FAN-WHEEL DIRECT DRIVE TWIN
16	6905-2RS-GPL-206	BEARING
17	VS-XVD-13	MOTOR 24V 600W
18	HMM SSS 10C.3/8	SCREW
19	127F-6	TEE STREET PIPE FORGED 3/8"
20	5A704	UNLOAD CHECK VALVE
21	28-158	ELBOW ST 3/8" 90° BARSTOCK
22	B-6-A	FEMALE TO MALE ADAPTOR
23	SS-280	SOCKET INTAKE STAFF 280
24	PR25-008	POP OFF VALVE
25	06115-06	PLUG FLAT 3/8
26	ISS-280	SHAFT ADAPTER
27*	AC1-2-10	SLEEVE, CYLINDER
28*	AC1-2-9	SCREW 1/4 20 x 5/8
29	AC1-2-11	PISTON CAP
30*	AC1-2-12	CUP PISTON AC-CUP
31	AC-2-8	ROD, BARE AC UNITS
32	AC-2-61	ECCENTRIC, INSIDE TWIN
33	AC2-BAI	ROD BEARING ASSEMBLY, INNER
QTY (1)	BTL-DDRB1	COMPRESSOR HEAD REBUILD KIT

(INCLUDED IN COMPRESSOR HEAD REBUILD KIT *)

USE OF EQUIPMENT IN THE BAHAMA ISLANDS

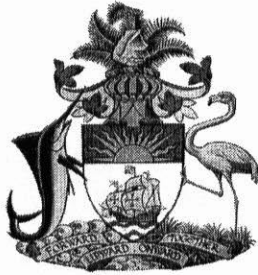

DEPARTMENT OF FISHERIES

Ministry of Agriculture, Fisheries
& Local Government
P. O. Box N-3028
Nassau, Bahamas
Fax: (242) 393-0238

MAF&LG/FIS/10

8 April 2003

Mr. Robert M. Carmichael
President/CEO
Brownie's Third Lung
940 Northwest 1st Street
Fort Lauderdale, FL33311
U.S.A.

Dear Mr. Carmichael,

Reference is made to your email of 26th March, 2003 that was addressed to the Bahamas' Ministry of Tourism relating to the usage of air compressors, hookah and scuba dive gear in the Bahamian exclusive economic zone.

Please be advised that current Bahamian laws do permit the possession and use of Scuba, hookah dive gear or air compressors for the purposes of recreational diving. However, the use of these apparatuses are strictly prohibited for the purposes of spearfishing or the collection of any marine resource while in Bahamian waters.

It is hoped that the above fulfills your request relating to the usage of the mentioned gear while in Bahamian waters.

Sincerely,

A handwritten signature in black ink, appearing to read 'Edison Deleveaux', written over a circular stamp.

Edison Deleveaux
For/DIRECTOR OF FISHERIES



940 NW 1st Street
Fort Lauderdale, FL 33311

PHONE: 954.462.5570 800.327.0412
FAX: 954.462.6115

www.browniesmarinegroup.com