



**ELECTRÓNICA Y ELECTRICIDAD PARA VEHÍCULOS**

**[WWW.CMELECTRONICA.COM.AR](http://WWW.CMELECTRONICA.COM.AR)**

**YAMAHA**

**Marine**

**Outboards**

**160**

**6V, 8V**

**SERVICE  
MANUAL**

## NOTICE

This manual has been prepared by the Yamaha Motor Company Ltd. primarily for use by Yamaha dealers and their trained mechanics when performing maintenance procedures and repairs to Yamaha equipment. It has been written to suit the needs of persons who have a basic understanding of the mechanical and electrical concepts and procedures inherent in the work, for without such knowledge attempted repairs or service to the equipment could render it unsafe or unfit for use.

Because the Yamaha Motor Company Ltd. has a policy of continuously improving its products, models may differ in detail from the descriptions and illustrations given in this publication. Use only the latest edition of this manual. Authorized Yamaha dealers are notified periodically of modifications and significant changes in specifications and procedures, and these are incorporated in successive editions of this manual.

A10001-0\*

**6V, 8V  
SERVICE MANUAL  
©1996 Yamaha Motor Co., LTD.  
1st. Edition, July 1996  
All rights reserved.**

**No part of this publication may be reproduced or transmitted in any form or by any means including photocopying and recording without the written permission of the copyright holder. Such written permission must also be obtained before any part of this publication is stored in a retrieval system of any nature.**

**Printed in USA  
P/N LIT-18616-01-64**

---

## HOW TO USE THIS MANUAL

### MANUAL FORMAT

All of the procedures in this manual are organized in a sequential, step-by-step format. The information has been compiled to provide the mechanic with an easy to read, handy reference that contains comprehensive explanations of all disassembly, repair, assembly, and inspection operations.

In this revised format, the condition of a faulty component will precede an arrow symbol and the course of action required will follow the symbol, e.g.,

● Bearings

Pitting/Damage → Replace.

To assist you to find your way about this manual, the Section Title and Major Heading is given at the head of every page.

An Index to contents is provided on the first page of each Section.

### MODEL INDICATION

Multiple models are shown in this manual. These indications are noted as follows.

<b>Model name</b>	6MH (USA, CANADA) 6CM	6CEM	8MH (USA, CANADA) 8CM	8CEM
<b>Indication</b>	6CM	6CEM	8CM	8CEM

### THE ILLUSTRATIONS

Some illustrations in this manual may differ from the model you have. This is because a procedure described may relate to several models, though only one may be illustrated. (The name of model described will be mentioned in the description.)

### REFERENCES

These have been kept to a minimum; however, when you are referred to another section of the manual, you are told the page number to go to.

# HOW TO READ DESCRIPTIONS

1. An easy-to-see disassembly illustration is mainly provided for a disassembly job.
2. Numbers are given in the order of a disassembly job in the disassembly illustration.
3. An explanation of jobs and notes is presented in an easy-to-read way by the use of symbol marks. The meanings of the symbol marks are given on the next page.
4. A job instruction chart accompanies the assembly illustration, providing the order of jobs, names of parts, notes in jobs, etc.
5. In addition to the disassembly illustration, "REMOVAL POINTS" is provided to supplement in detail the explanation which does or cannot necessarily cover the main jobs.
6. Jobs necessary before and after those which are not included in the disassembly illustration are explained before the same illustration as related jobs.

- |                           |                     |
|---------------------------|---------------------|
| ① Section                 | ⑥ Remarks           |
| ② Preparation for removal | ⑦ Removal points    |
| ③ Order of removal        | ⑧ Extent of removal |
| ④ Part name               | ⑨ Symbol mark       |
| ⑤ Q'ty                    | ⑩ Exploded diagram  |

**POWR** **CYLINDER HEAD, VALVE AND CAMSHAFT** E

**CYLINDER HEAD, VALVE AND CAMSHAFT**

**PREPARATION FOR REMOVAL**

- Remove the power unit.
- Remove the following parts:
  - CDI unit
  - Ignition coil
  - Magneto base
  - Rectifier regulator
  - Flywheel magneto
  - Timing belt

**A** 2 mm (0.2 mm), L4 (7/16)  
**B** 8 mm (0.8 mm), 0.8 mm  
**C** 13 mm (1.3 mm), 0.4 mm  
**D** 10 mm (1.0 mm), 1.3 mm  
**E** 10 mm (1.0 mm), 11 mm  
**F** 30 mm (3.0 mm), 22 mm

8-23

**POWR** **CYLINDER HEAD, VALVE AND CAMSHAFT** E

**NOTE ON REMOVAL AND REASSEMBLY**

- Before servicing, clean the power unit.
- Remove any gasket adhered to the contacting surfaces.
- Take care not to scratch the contacting surfaces when removing the cylinder and cylinder head.
- For reassembly, the removed parts should be cleaned with solvent, and apply the gear oil to the sliding surfaces.

Extent of removal: 1. Intake manifold removal 2. Cylinder head removal 3. Oil pump assembly removal 4. Valve disassembly

Extent of removal	Order	Part name	Q'ty	Remarks
①	1	Bolt	3	
	2	Intake manifold	1	
	3	Bolt	4	
	4	Head cover	1	
	5	Bolt	8	
	6	Cylinder head	1	Refer to "REMOVAL POINTS"
	7	Bit	3	
	8	Oil pump assembly	1	
	9	Adjust screw	4	Loosen the screw.
	10	Valve lifter	2	Refer to "REMOVAL POINTS"
	11	Rocker shaft	2	
	12	Rocker arm	4	
	13	Bolt	1	
	14	Driven gear	1	Refer to "REMOVAL POINTS"
	15	Camshaft	1	
	16	Valve collar	4	
	17	Valve (intake)	2	Refer to "REMOVAL POINTS"
	18	Spring returner	2	
	19	Valve (exhaust)	2	

**REMOVAL POINTS**

**CYLINDER HEAD**

1. Remove  
 • Cylinder head ①

**NOTE:**

- To remove the cylinder head, insert a bar between the cylinder head and cylinder body, and then separate it.
- Do not to scratch the gasket surfaces by the screw driver.

**ROCKER SHAFT**

1. Loosen  
 • Lock nut ①  
 • Adjust bolt ②

Valve adjuster:  
 YB-6035/50950-01311

8-24

---

## **WARNINGS, CAUTIONS AND NOTES**

Attention is drawn to the various Warnings, Cautions and Notes which distinguish important information in this manual in the following way.

 The Safety Alert Symbol means **ATTENTION! BECOME ALERT! YOUR SAFETY IS INVOLVED!**

---

### **WARNING**

**Failure to follow WARNING instruction could result in severe injury or death to the machine operator, a bystander, or a person inspecting or repairing the outboard motor.**

---

---

### **CAUTION**

**A CAUTION indicates special precautions that must be taken to avoid damage to the outboard motor.**

---

---

### **NOTE:**

**A NOTE provides key information to make procedures easier or clearer.**

---

**SYMBOLS**

Symbols ① to ⑨ are designed as thumb-tabs to indicate the content of a chapter.

- ① General Information
- ② Specifications
- ③ Periodic Inspection and Adjustment
- ④ Fuel System
- ⑤ Power Unit
- ⑥ Lower Unit
- ⑦ Bracket Unit
- ⑧ Electrical System
- ⑨ Troubleshooting

Symbols ⑩ to ⑯ indicate specific data:

- ⑩ Special tool
- ⑪ Specified liquid
- ⑫ Specified grease
- ⑬ Specified engine speed
- ⑭ Specified torque
- ⑮ Specified measurement
- ⑯ Specified electrical value  
[Resistance ( $\Omega$ ), Voltage (V), Electric current (A)]

Symbol ⑰ to ⑳ in an exploded diagram indicate grade of lubricant and location of lubrication point:

















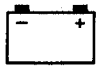





- ⑰ Apply Yamaha 2-stroke outboard motor oil
- ⑱ Apply Yamaha gear-case lubricant
- ⑲ Apply molybdenum disulfide oil
- ⑳ Apply water resistant grease (Yamaha marine grease A, Yamaha marine grease)

Symbols ㉑ to ㉔ in an exploded diagram indicate grade of sealing or locking agent, and location of application point:









- ㉑ Apply Gasket Maker<sup>®</sup>
- ㉒ Apply LOCTITE<sup>®</sup> No. 271 (Red LOCTITE)
- ㉓ Apply LOCTITE<sup>®</sup> No. 242 (Blue LOCTITE)
- ㉔ Apply LOCTITE<sup>®</sup> No. 572

**NOTE:**

In this manual, the above symbols may not be used in every case.

① GEN INFO 	② SPEC 
③ INSP ADJ 	④ FUEL 
⑤ POWR 	⑥ LOWR 
⑦ BRKT 	⑧ ELEC 
⑨ TRBL SHTG ?	⑩ 
⑪ 	⑫ 
⑬ 	⑭ 
⑮ 	⑯ 
⑰ 	⑱ 
⑲ 	⑳ 
㉑ 	㉒ 
㉓ 	㉔ 

# INDEX

<b>GENERAL INFORMATION</b>	 GEN INFO	<b>1</b>
<b>SPECIFICATIONS</b>	 SPEC	<b>2</b>
<b>PERIODIC INSPECTION AND ADJUSTMENT</b>	 INSP ADJ	<b>3</b>
<b>FUEL SYSTEM</b>	 FUEL	<b>4</b>
<b>POWER UNIT</b>	 POWR	<b>5</b>
<b>LOWER UNIT</b>	 LOWR	<b>6</b>
<b>BRACKET UNIT</b>	 BRKT	<b>7</b>
<b>ELECTRICAL SYSTEM</b>	 ELEC	<b>8</b>
<b>TROUBLESHOOTING</b>	 TRBL SHTG	<b>9</b>



---

**CHAPITRE 1  
GENERAL INFORMATION**

**IDENTIFICATION**..... 1-1  
    SERIAL NUMBER ..... 1-1  
    STARTING SERIAL NUMBERS ..... 1-1

**SAFETY WHILE WORKING** ..... 1-2  
    FIRE PREVENTION ..... 1-2  
    VENTILATION ..... 1-2  
    SELF-PROTECTION ..... 1-2  
    OILS, GREASES AND SEALING FLUIDS ..... 1-2  
    GOOD WORKING PRACTICES ..... 1-3  
    DISASSEMBLY AND ASSEMBLY ..... 1-4

**SPECIAL TOOLS** ..... 1-5  
    FOR TUNE-UP ..... 1-5  
    FOR POWER UNIT SERVICE..... 1-7  
    FOR LOWER UNIT SERVICE..... 1-7

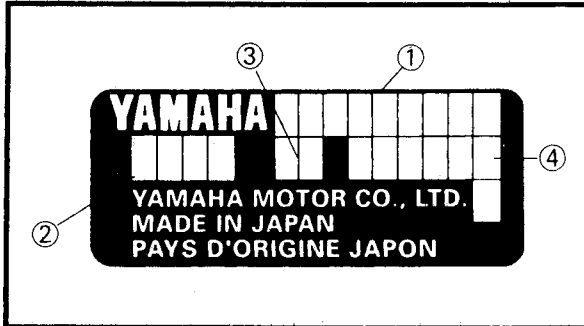
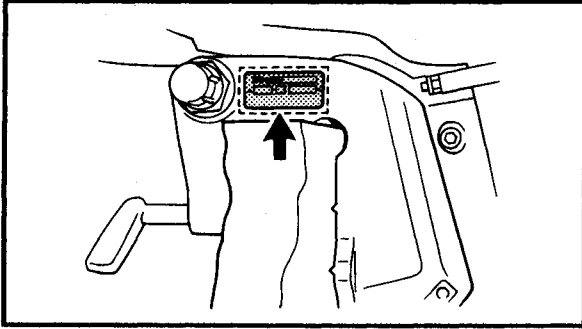

A60000-1\*

**IDENTIFICATION  
SERIAL NUMBER**

The serial number of the outboard motor is stamped on a plate attached to the port side of the clamp bracket.

**NOTE:**

As an antitheft measure, a special label on which the outboard motor serial number is stamped is bonded to the portside of the clamp bracket. The label is specially treated so that peeling it off causes cracks across the serial number.

- ① Model name
- ② Approved model No.
- ③ Transom height
- ④ Serial number

**STARTING SERIAL NUMBERS**

The starting serial number blocks are as follows:

Model		Approved model code	Starting serial No.
World-wide	USA, CANADA		
6CM	6MH	6H6	S: 003802 ~ L: 303150 ~
6CEM	—		S: 100101 ~ L: 400101 ~
8CM	8MH	6G1	S: 008601 ~ L: 305566 ~
8CEM	—		UL: 700101 ~ S: 100101 ~ L: 100101 ~

**SAFETY WHILE WORKING**

The procedures given in this manual are those recommended by Yamaha to be followed by Yamaha dealers and their mechanics.

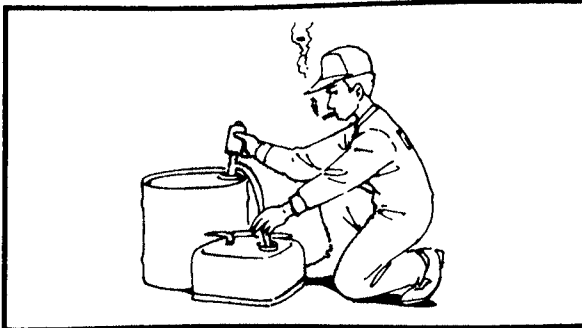
**FIRE PREVENTION**

Gasoline (petrol) is highly flammable. Petroleum vapor is explosive if ignited. Do not smoke while handling, and keep it away from heat, sparks, and open flames.

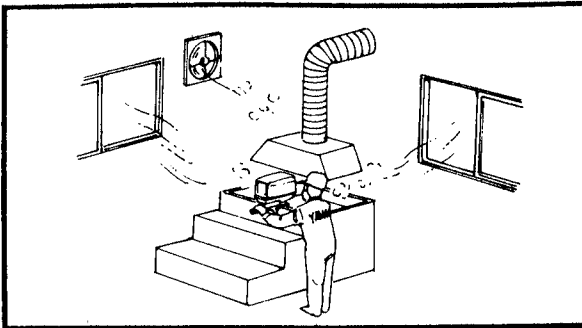
**VENTILATION**

Petroleum vapor is heavier than air and if inhaled in large quantities will not support life. Engine exhaust gases are harmful to breathe. When test-running an engine indoors, maintain good ventilation.

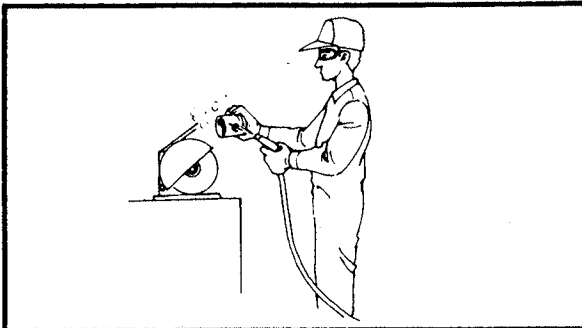
**SELF-PROTECTION**

Protect your eyes with suitable safety spectacles or safety goggles when using compressed air, when grinding or when doing any operation which may cause particles to fly off. Protect hands and feet by wearing safety gloves or protective shoes if appropriate to the work you are doing.

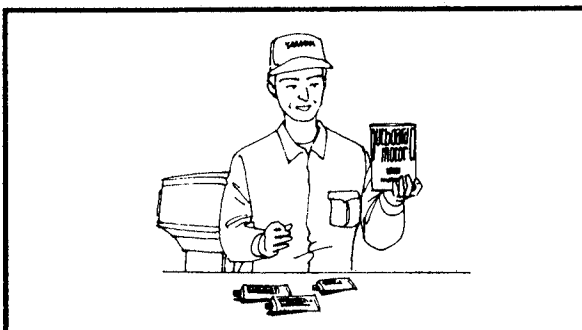
**OILS, GREASES AND SEALING FLUIDS**

Use only genuine Yamaha oils, greases and sealing fluids or those recommended by Yamaha.

Under normal conditions of use, there should be no hazards from the use of the lubricants mentioned in this manual, but safety is all-important, and by adopting good safety practices, any risk is minimized.

A summary of the most important precautions is as follows:

1. While working, maintain good standards of personal and industrial hygiene.
2. Clothing which has become contaminated with lubricants should be changed as soon as practicable, and laundered before further use.
3. Avoid skin contact with lubricants; do not, for example, place a soiled wiping-rag in one's pocket.
4. Hands, and any other part of the body which have been in contact with lubricants or lubricant-contaminated clothing, should be thoroughly washed with hot water and soap as soon as practicable.
5. To protect the skin, the application of a suitable barrier cream to the hands before working is recommended.
6. A supply of clean lint-free cloths should be available for wiping purposes.



### **GOOD WORKING PRACTICES**

1. **The right tools**  
Use the special tools that are advised to protect parts from damage. Use the right tool in the right manner — don't improvise.
2. **Tightening torque**  
Follow the torque tightening instructions. When tightening bolts, nuts and screws, tighten the large sizes first, and tighten inner-positioned fixings before outer-positioned ones.

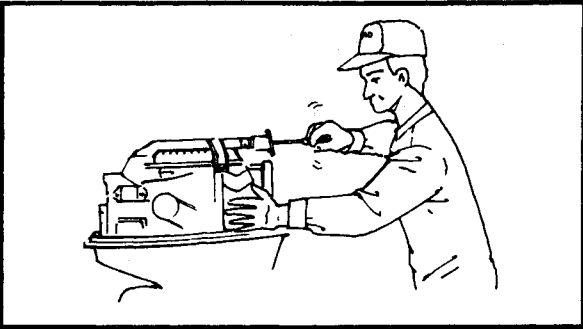
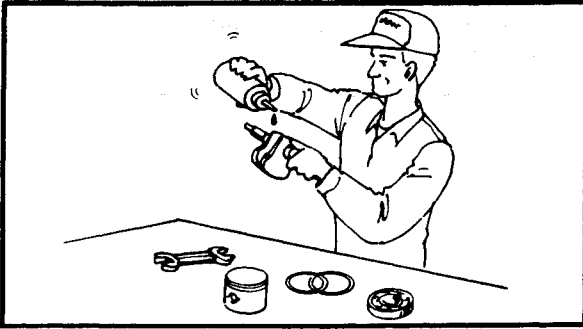
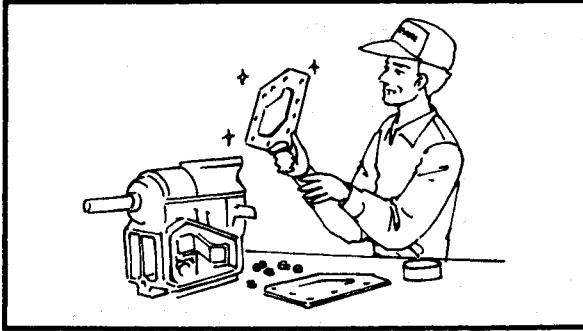
**3. Non-reusable items**

Always use new gaskets, packings, O-rings, split-pins and circlips etc. on reassembly.

**DISASSEMBLY AND ASSEMBLY**

1. Clean parts with compressed-air on disassembling them.
2. Oil the contact surfaces of moving parts on assembly.

3. After assembly, check that moving parts operate normally.

4. Install bearings with the manufacturer's markings on the side exposed to view, and liberally oil the bearings.
5. When installing oil seals, apply a light coating of water-resistant grease to the outside diameter.

A80701-0\*

**SPECIAL TOOLS**

The use of correct special tools recommended by Yamaha will aid the work and enable accurate assembly and tune-up. Improvisations and use of improper tools can cause damage to the equipment.

**NOTE:**

- For U.S.A. and Canada, use part number starting with "YB-", "YU-" or "YW-".
- For others, use part number starting with "90890-".

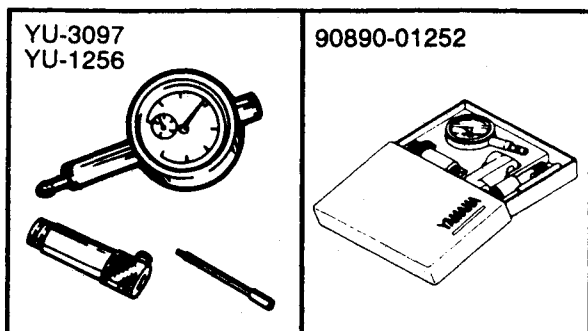

**FOR TUNE-UP**

1. Dial gauge and stand  
P/N. YU-3097, YU-1256  
90890-01252

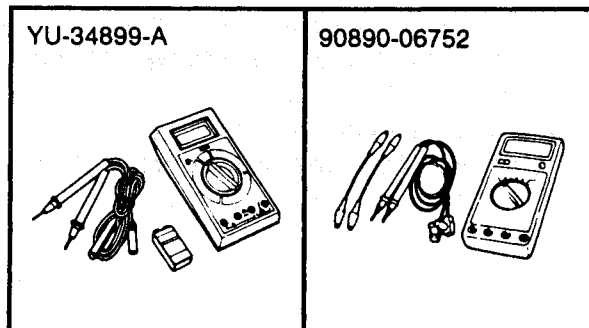

2. Digital multi meter  
P/N. YU-34899-A  
90890-06752

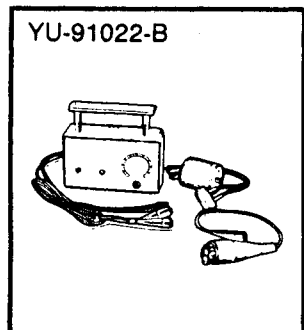

3. C.D.I. tester  
P/N. YU-91022-B

**GEN  
INFO**



**SPECIAL TOOLS**

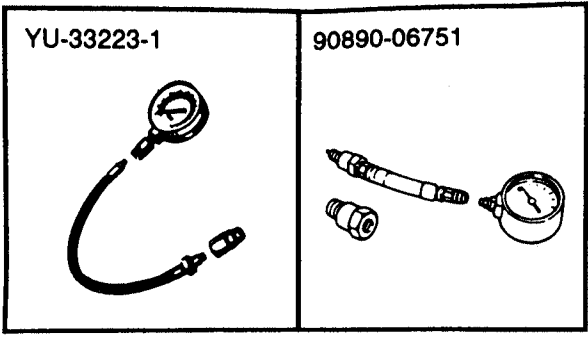

4. Compression gauge  
P/N. YU-33223-1  
90890-06751

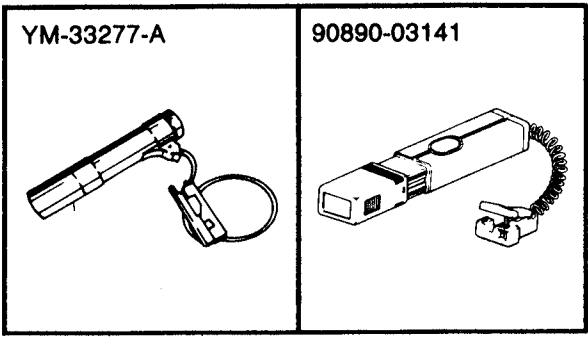

5. Timing light  
P/N. YM-33277-A  
90890-03141

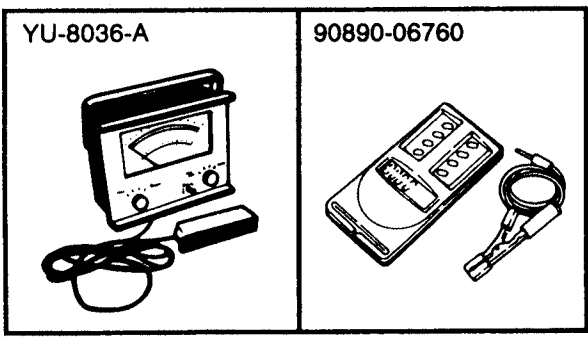

6. Tachometer  
P/N. YU-8036-A  
90890-06760

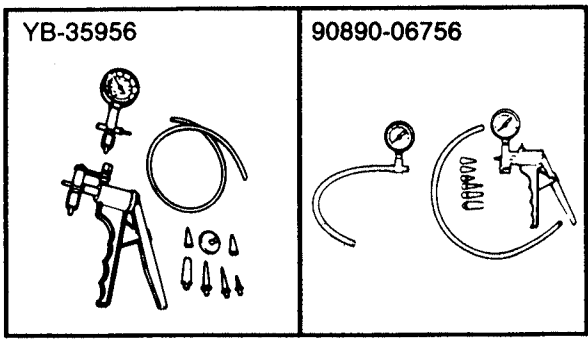

7. Mity Vac  
P/N. YB-35956  
90890-06756

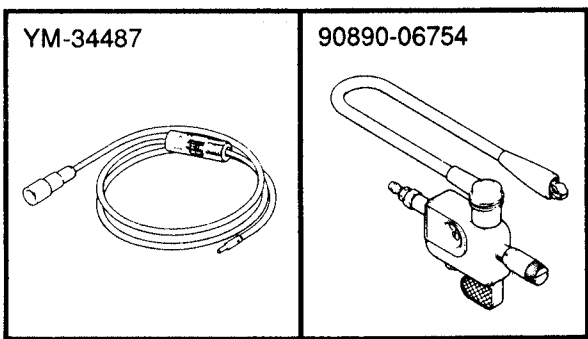

8. Spark gap tester  
P/N. YM-34487  
90890-06754

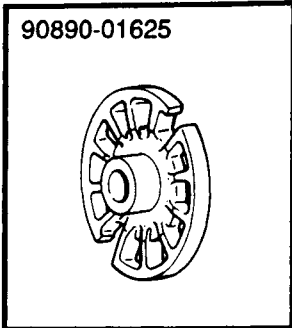

9. Tester propeller  
P/N.  
90890-01625

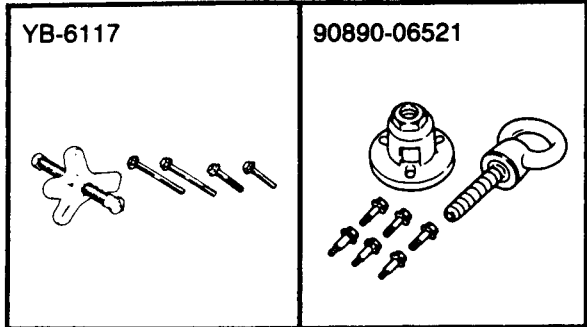

**FOR POWER UNIT SERVICE**

1. Flywheel puller  
P/N. YB-6117  
90890-06521

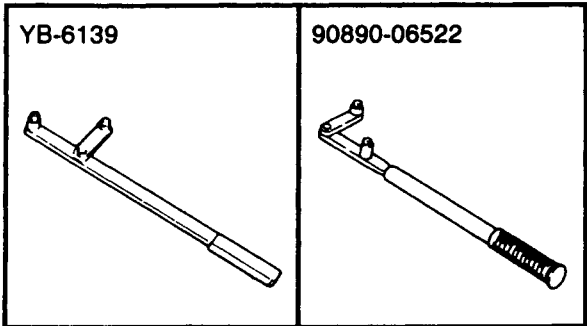

2. Flywheel holder  
P/N. YB-6139  
90890-06522

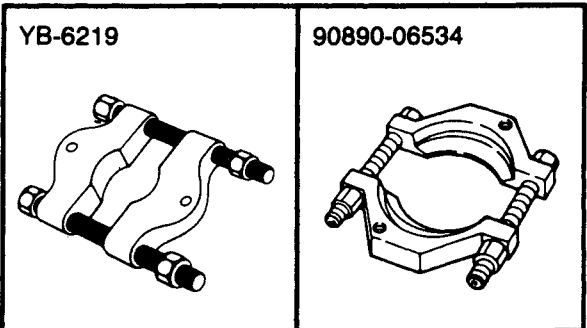

3. Bearing separator  
P/N. YB-6219  
90890-06534

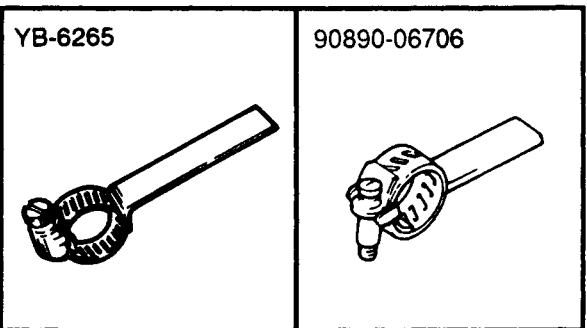

**FOR LOWER UNIT SERVICE**

1. Backlash indicator  
P/N. YB-6265  
90890-06706





90890-06501

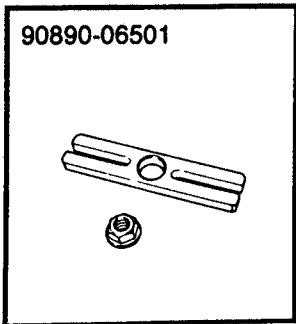

2. Stopper guide plate  
P/N.  
90890-06501

YB-6096

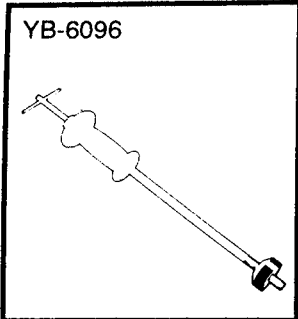

3. Slide hammer set  
P/N. YB-6096

YB-6219

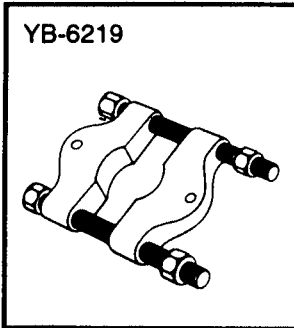

90890-06534

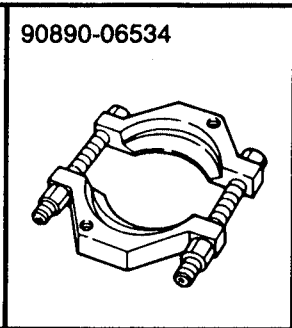

4. Bearing separator  
P/N. YB-6219  
90890-06534

90890-06535

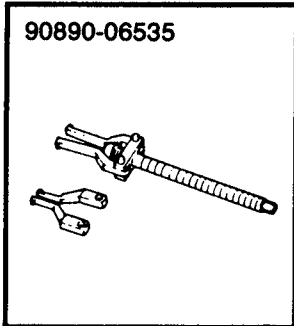

5. Bearing puller  
P/N.  
90890-06535

90890-06538

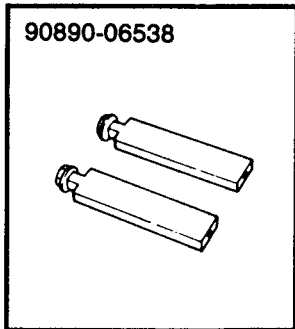

6. Stopper guide stand  
P/N.  
90890-06538

**GEN  
INFO** 

**SPECIAL TOOLS**

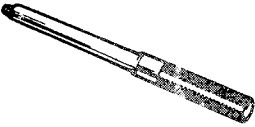
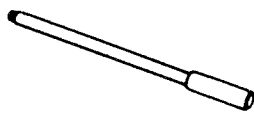
<p>YB-6229 YB-6071</p>	<p>90890-06605 90890-06606 90890-06652</p>
	

7. Drive rod  
 P/N. YB-6229, YB-6071  
 90890-06605  
 90890-06606  
 90890-06652

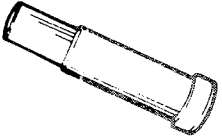
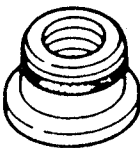
<p>YB-6028</p>	<p>90890-06649 90890-06650</p>
	

8. Bushing attachment  
 P/N. YB-6028  
 90890-06649  
 90890-06650

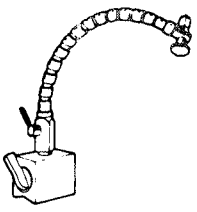
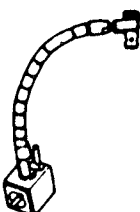
<p>YU-34481</p>	<p>90890-06705</p>
	

9. Magnet base  
 P/N. YU-34481  
 90890-06705

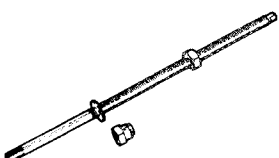
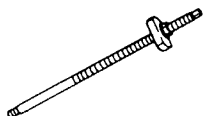
<p>YB-6029</p>	<p>90890-06601</p>
	

10. Bushing installer  
 P/N. YB-6029  
 90890-06601

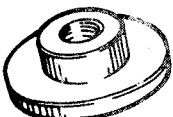
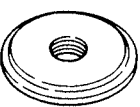
<p>YB-6015 YB-6021 YB-6167</p>	<p>90890-06634 90890-06628</p>
	

11. Bearing (oil seal) installer  
 P/N. YB-6015, YB-6021, YB-6167  
 90890-06634  
 90890-06628



YB-6117

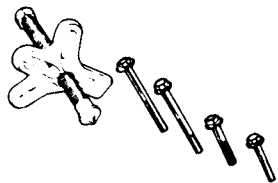

12. Universal puller  
P/N. YB-6117

YB-6169

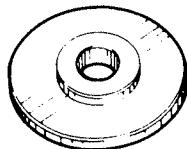

13. Needle bearing installer  
P/N. YB-6169

YB-06234

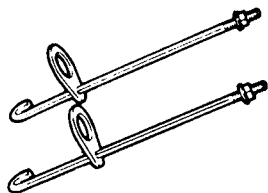

14. Bearing housing puller  
P/N. YB-06234

90890-06645

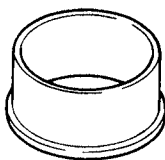

15. Bearing inner race attachment  
P/N.  
90890-06645

---

## **CHAPTER 2 SPECIFICATION**

<b>GENERAL SPECIFICATIONS .....</b>	<b>2-1</b>
<b>MAINTENANCE SPECIFICATIONS .....</b>	<b>2-3</b>
ENGINE .....	2-3
LOWER .....	2-5
ELECTRICAL .....	2-5
DIMENTION .....	2-8
TIGHTENING TORQUE .....	2-9
GENERAL TORQUE SPECIFICATIONS .....	2-9



**GENERAL SPECIFICATIONS**

Item		Unit	Model			
Worldwide			6CM	6CEM	8CM	8CEM
USA, CANADA			6MH	—	8MH	—
MODEL CODE:			6M8		6N0	
DIMENSIONS:						
Overall length		mm (in)	802 (31.6)			
Overall width		mm (in)	343 (13.5)			
Overall height	S	mm (in)	977 (38.5)			
	L	mm (in)	1,104 (43.5)			
Boat transom height	UL	mm (in)	—		1,167 (45.9)	—
	S	mm (in)	381 (15.0)			
	L	mm (in)	508 (20.0)			
O/M transom height	UL	mm (in)	—		635 (25.0)	—
	S	mm (in)	436 (17.2)			
	L	mm (in)	563 (22.2)			
Weight	UL	mm (in)	—		626 (24.6)	—
	S	kg (lb)	27 (59.5)	29 (63.9)	27 (59.5)	29 (63.9)
	L	kg (lb)	27.5 (60.6)	29.5 (65.0)	27.5 (60.6)	29.5 (65.0)
	UL	kg (lb)	—		28 (61.7)	—
PERFORMANCE:						
Full throttle speed range		rpm	4,000 ~ 5,000		4,500 ~ 5,500	
Output (ISO)		kw (hp)/rpm	4.4 (6)/4,500		5.9 (8)/5,000	
Max fuel consumption		L (qt)/h at rpm	3.6 (8)/5,000		4.5 (10)/5,500	
ENGINE:						
Engine type			2-stroke			
Cylinder number			2			
Total displacement		cm <sup>3</sup> (cu. in)	165 (10.07)			
Bore x Stroke		mm x mm	50 x 42			
		(in x in)	(1.97 x 1.65)			
Compression ratio			7.00			
Compression pressure		kPa	1,079			
		(kg/cm <sup>2</sup> , psi)	(10.8, 153)			
Carburetor number			1			
Intake system			Reed valve			
Scavenging system			Cross scavenging			
Exhaust system			Through prop boss			
Cooling system			Water			
Starting system			Manual	Manual & Electric	Manual	Manual & Electric
Ignition system			CDI			
Advance type			Mechanical			
Alternator for charging		V-A	—	12-6	—	12-6
Alternator for lighting		V-W	12-80	—	12-80	—
Carburetor starting system			Choke valve type			
Spark plug (NGK)		V-W	B7HS-10			



# GENERAL SPECIFICATIONS

Item	Unit	Model			
		6CM	6CEM	8CM	8CEM
		6MH	—	8MH	—
Worldwide					
USA, CANADA					
Resistant spark plug (NGK)		BR7HS-10			
<b>FUEL AND LUBRICATION:</b>					
Fuel	P.O.N.*1	Regular gasoline			
Fuel rating		Min. 86			
Fuel type		Pre-mixed fuel & oil			
Engine oil type		2-stroke outboard motor oil			
Engine oil grade		TC-W3			
Mixing ratio (G)		100 : 1			
Gear oil type		Hypoid gear oil-SAE#90			
Gear oil quantity	cm <sup>3</sup> (US oz, Imp oz)	160 (5.4, 5.6)			
<b>BRACKET:</b>					
Tilt angle	degree	4, 8, 12, 16, 20			
Tilt-up angle	degree	81			
Shallow water cruising angle	degree	Tilt angle+37			
Steering angle (left + right)	degree	60 + 60			
<b>DRIVE UNIT:</b>					
Gear shift position		F-N-R			
Gear ratio		13:27 (2.08)			
Gear type		Straight bevel gear			
Clutch type		Dog clutch			
Propeller direction		Clockwise (back view)			
Propeller drive system		Spline			
Propeller series mark		N			
<b>ELECTRICAL:</b>					
Battery capacity	Ah	—	40	—	40
Cold cranking	Amps	—	210	—	210

\*1 : Pump Octance Number; (Reserch octane + Motor octane)/2



**MAINTENANCE SPECIFICATIONS**

**ENGINE**

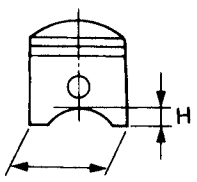
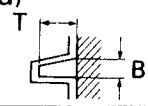
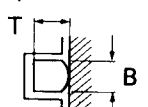
Item	Unit	Model			
		6CM	6CEM	8CM	8CEM
		6MH	—	8MH	—
Worldwide USA, CANADA					
<b>CYLINDER:</b>					
Bore size	mm (in)	50.00 ~ 50.03 (1.9685 ~ 1.9697)			
Wear limit	mm (in)	50.1 (1.972)			
Taper limit	mm (in)	0.08 (0.003)			
Out of round limit	mm (in)	0.05 (0.002)			
<b>PISTON:</b>					
Identification mark		G			
Piston clearance	mm (in)	0.040 ~ 0.045 (0.0016 ~ 0.0018)			
Limit	mm (in)	0.095 (0.0037)			
Diameter	mm (in)	49.955 ~ 49.980 (1.9667 ~ 1.9677)			
Measuring point H	mm (in)	10 (0.4)			
					
Off-set	mm (in)	0.5 (0.02)			
Off-set direction		Exhaust side			
Pin boss inside diameter	mm (in)	12.004 ~ 12.015 (0.4726 ~ 0.4730)			
Ring groove clearance					
(installed) Top	mm (in)	0.02 ~ 0.06 (0.0008 ~ 0.0024)			
2nd	mm (in)	0.03 ~ 0.07 (0.0012 ~ 0.0028)			
Over size piston diameter					
1st*	mm (in)	50.25 (1.978)*			
2nd	mm (in)	50.50 (1.988)			
<b>PISTON PIN:</b>					
Diameter	mm (in)	11.996 ~ 12.000 (0.4723 ~ 0.4724)			
<b>PISTON RING (1ST):</b>					
Type		Keystone			
Dimensions (B × T)	mm (in)	2.0 × 2.0 (0.079 × 0.079)			
End gap (installed)	mm (in)	0.15 ~ 0.35 (0.006 ~ 0.014)			
Limit	mm (in)	0.55 (0.022)			
					
<b>PISTON RING (2ND):</b>					
Type		Barrel			
Dimensions (B × T)	mm (in)	2.0 × 2.0 (0.079 × 0.079)			
End gap (installed)	mm (in)	0.15 ~ 0.35 (0.006 ~ 0.014)			
Limit	mm (in)	0.55 (0.022)			
					

\* Except for U.S.A.

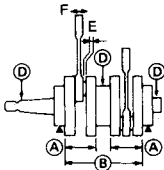

Item	Unit	Model			
		6CM	6CEM	8CM	8CEM
		6MH	—	8MH	—
Worldwide					
USA, CANADA					
<b>CRANK SHAFT:</b>					
Crank width "A"	mm (in)	39.90 ~ 39.95 (1.571 ~ 1.573)			
Crank width "B"	mm (in)	101.7 ~ 102.0 (4.004 ~ 4.016)			
Deflection limit "D"	mm (in)	0.03 (0.0012)			
Crank shaft side clearance "E"	mm (in)	0.2 ~ 0.7 (0.008 ~ 0.027)			
Maximum small end axial play "F"	mm (in)	2.0 (0.08)			
					
<b>THERMOSTAT:</b>					
Opening temperature	°C (°F)	48 ~ 52 (118 ~ 126)			
Full-opening temperature	°C (°F)	60 (140)			
Valve lift	mm (in)	More than 3 (0.12)			
<b>REED VALVE:</b>					
Valve stopper height	mm (in)	4.5 ± 0.2 (0.177 ± 0.008)			
Valve warpage limit	mm (in)	0.2 (0.008)			
<b>CARBURETOR:</b>		6H601		6G101	
Identification Mark					
Float height	mm (in)	14 ± 2.0 (0.55 ± 0.08)			
Valve seat size	mm (in)	1.2 (0.047)			
Main jet (M.J.)		#98			
Main nozzle (M.N.)	mm (in)	2.2 (0.087)		2.4 (0.094)	
Pilot jet (P.J.)		#45			
Pilot screw (P.S.)	turns out	1-1/8 ± 1/4			
Idle speed	rpm	900 ± 50			
Trolling speed	rpm	800 ± 50			
<b>RECOIL STARTER:</b>					
Starter rope length	mm (in)	1,850 (72.8)			





**LOWER**

Item	Unit	Model			
		6CM	6CEM	8CM	8CEM
		6MH	—	8MH	—
Worldwide					
USA, CANADA					
<b>GEAR BACKLASH:</b>					
Pinion-forward (S.S.T.)	mm	0.25 ~ 0.75			
Pinion-reverse (S.S.T.)	mm	0.25 ~ 0.75			
Pinion shims	mm	1.9/2.0/2.1/2.2			
Forward shims	mm	0.10/0.12/0.15/0.18/0.30/0.40/0.50			
Reverse shims	mm	0.10			
<b>PROPELLER:</b>					
Size	in	3 × 8 1/2 × 6 1/2 – N			
(Blade × diameter × pitch)		3 × 8 1/2 × 7 1/2 – N			
		3 × 8 1/2 × 8 1/2 – N			
		3 × 9 × 5 – N			
		3 × 9 × 7 – N			
<b>TEST PROPELLER</b>		90890-01625		90890-01625	
Engine speed	rpm	4,500 ~ 4,700		5,300 ~ 5,500	

**ELECTRICAL**

Item	Unit	Model			
		6CM	6CEM	8CM	8CEM
		6MH	—	8MH	—
Worldwide					
USA, CANADA					
<b>IGNITION TIMING:</b>					
Ignition timing	degree	B.T.D.C. 4 ± 1			
(at full retarded)	degree	B.T.D.C. 35 ± 1			
(at full advanced)					
Piston position	mm (in)	B.T.D.C. 0.08 ± 0.04 (0.0031 ± 0.0016)			
(at full retarded)	mm (in)	B.T.D.C. 4.79 ± 0.26 (0.189 ± 0.010)			
(at full advanced)					
<b>STARTER MOTOR:</b>					
Output	kW	—	0.4	—	0.4
Brush length	mm (in)	—	7.5 (0.30)	—	7.5 (0.30)
Wear limit	mm (in)	—	4.5 (0.18)	—	4.5 (0.18)
Commutator diameter	mm (in)	—	20.0 (0.79)	—	20.0 (0.79)
Limit	mm (in)	—	19.4 (0.76)	—	19.4 (0.76)
Clutch type		—	Over running	—	Over running
Rating	Sec.	—	30	—	30
<b>STARTER RELAY:</b>					
Rating	V/Sec.	—	12/30	—	12/30

**SPEC**

**MAINTENANCE SPECIFICATIONS**

Item	Unit	Model			
		6CM	6CEM	8CM	8CEM
Worldwide					
USA, CANADA		6MH	—	8MH	—
<b>NEUTRAL SWITCH:</b>					
Distance A (ON)	mm (in)	—	18.5 ~ 19.5 (0.73 ~ 0.77)	—	18.5 ~ 19.5 (0.73 ~ 0.77)
Distance B (OFF)	mm (in)	—	19.6 ~ 20.5 (0.77 ~ 0.81)	—	19.6 ~ 20.5 (0.77 ~ 0.81)
<b>FUSE:</b>					
Rating	V/A	—	12/10	—	12/10
<b>STATOR ASSEMBLY:</b>					
Pulser coil resistance	$\Omega$	92 ~ 112 (W/R-B)			
Charge coil resistance	$\Omega$	81 ~ 99 (Br-B)			
Lighting voltage (minimum)	V/rpm	12/3,000			
Lighting voltage (maximum)	V/rpm	13.5 ~ 16.5/5,500			
Lighting coil resistance	$\Omega$	0.36 ~ 0.44 (G-G)			
Pole number		4			
<b>IGNITION COIL:</b>					
Primary coil resistance	$\Omega$	0.25 ~ 0.35 (O-B)			
Secondary coil resistance	k $\Omega$	6.8 ~ 10.2 (high tension cords)			
<b>SPARK PLUG:</b>					
Gap	mm (in)	0.9 ~ 1.0 (0.035 ~ 0.039)			
(resistance)	mm (in)	0.9 ~ 1.0 (0.035 ~ 0.039)			



Item	Unit	Model			
		6CM	6CEM	8CM	8CEM
		Worldwide	6MH	—	8MH
USA, CANADA					

C.D.I. UNIT:  
Resistance

KΩ

⊖ ⊕	W	B	Br	W/R	O
W	∞	∞	∞	∞	∞
B	∞	∞	7.5 ~ 11.3	∞	•
Br	∞	63.2 ~ 94.8	∞	∞	•
W/R	8.8 ~ 13.2	14.4 ~ 21.6	30.4 ~ 45.6	∞	•
O	∞	∞	∞	∞	∞

• : Needle swings once and returns to home position.  
∞ : Discontinuity

B : Black  
Br : Brown  
G : Green  
O : Orange  
W : White  
W/R : White/Red

RECTIFIER-REGURATOR:

6CM	✓	6CEM	
8CM	✓	8CEM	

⊖ ⊕	R	G	G/W	B
R	∞	∞	∞	∞
G	○	∞	∞	∞
G/W	○	∞	∞	∞
B	○	○	○	∞

○ : Continuity  
∞ : Discontinuity

B : Black  
G : Green  
G/W : Green/White  
R : Red

RECTIFIER:

6CM		6CEM	✓
8CM		8CEM	✓

⊖ ⊕	R	G1	G2	B
R	∞	∞	∞	∞
G1	○	∞	∞	∞
G2	○	∞	∞	∞
B	○	○	○	∞

○ : Continuity  
∞ : Discontinuity

B : Black  
G1,2: Green  
R : Red

**DIMENTION**

Item		Unit	Model			
			6CM	6CEM	8CM	8CEM
Worldwide	USA, CANADA		6MH	—	8MH	—
H4	(S)	mm (in)	436 (17.2)			
	(L)	mm (in)	563 (22.2)			
	(UL)	mm (in)	626 (24.6)			
B13		mm (in)	115 (4.5)			
B14		mm (in)	128 (5.0)			
C1		mm (in)	19 (0.75)			
C2		mm (in)	60 (2.36)			

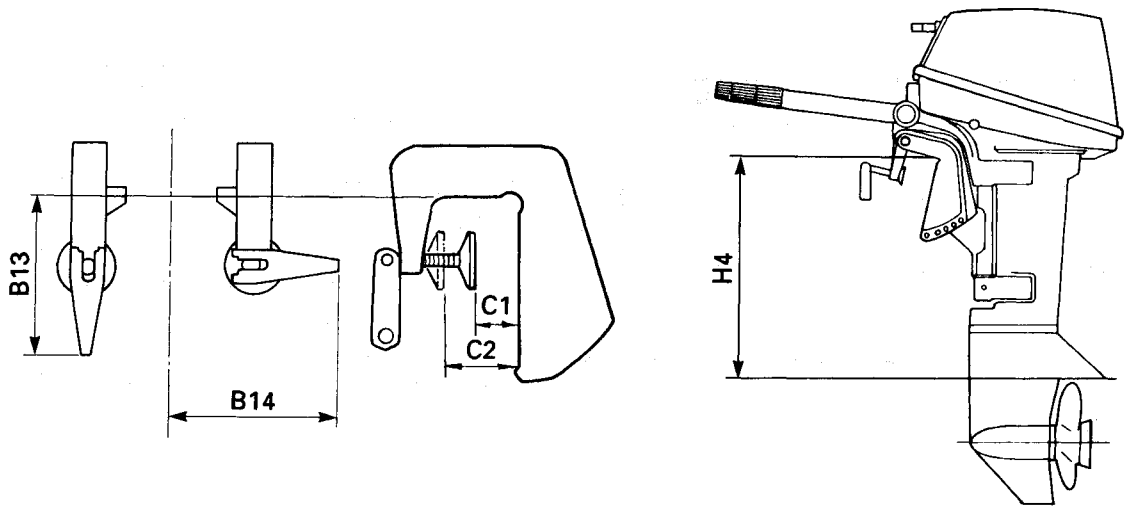



**TIGHTENING TORQUE**

Part to be tightened	Part name	Thread size	Q'ty	Tightening torque			Remarks	
				Nm	m • kg	ft • lb		
<b>ENGINE:</b>								
Crank case	1st	Bolt	M6	10	6	0.6	4.3	242
	2nd				11	1.1	8.0	
Cylinder head cover	1st	Bolt	M6	7	4	0.4	2.9	5
	2nd				8	0.8	5.8	
Exhaust cover	1st	Bolt	M6	7	4	0.4	2.9	572
	2nd				8	0.8	5.8	
Flywheel		Nut	M10	1	45	4.5	32	5
Spark plug		Bolt	M14	2	25	2.5	18	
<b>UPPER CASING AND GEAR CASE:</b>								
Clamp bracket		Nut	M8	1	7	0.7	5.1	
Water pump housing		Bolt	M6	4	11	1.1	8.0	572
Propeller		Nut	M10	1	17	1.7	12	

Nut (A)	Bolt (B)	General torque specifications		
		Nm	m • kg	ft • lb
8 mm	M5	5.0	0.5	3.6
10 mm	M6	8.0	0.8	5.8
12 mm	M8	18	1.8	13
14 mm	M10	36	3.6	25
17 mm	M12	43	4.3	31

**GENERAL TORQUE SPECIFICATIONS**

This chart specifies the torque for tightening standard fasteners with standard clean dry ISO threads at room temperature. Torque specifications for special components or assemblies are given in applicable sections of this manual. To avoid causing warpage, tighten multi-fastener assemblies in crisscross fashion, in progressive stages until the specified torque is reached.

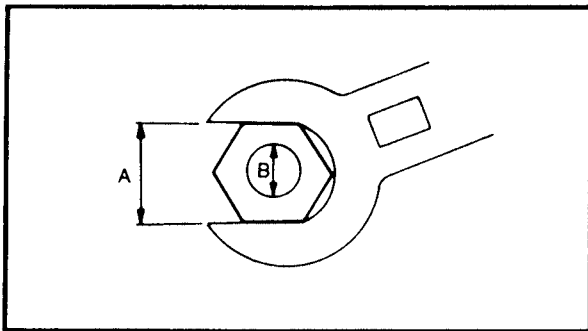

## CHAPTER 3

# PERIODIC INSPECTION AND ADJUSTMENT

<b>PREDELIVERY SERVICE</b> .....	3-1
CONTENTS .....	3-1
ELECTRICAL WIRING .....	3-2
FUEL LINE .....	3-4
GEAR OIL LEVEL .....	3-5
OPERATION OF CONTROLS AND MOVING PARTS .....	3-5
FUEL LEAKAGE .....	3-6
WATER LEAKAGE .....	3-6
EXHAUST LEAKAGE .....	3-6
ENGINE AND LOWER UNIT NOISE .....	3-6
IDLE-SPEED .....	3-6
IGNITION TIMING .....	3-6
MOTOR EXTERIOR .....	3-6
INSTRUCTING THE NEW OWNER .....	3-6
 <b>PERIODIC SERVICE</b> .....	 3-7
MAINTENANCE SCHEDULE .....	3-7
ANODE .....	3-8
PROPELLER .....	3-8
BATTERY .....	3-9
FUEL LINE .....	3-10
FUEL STRAINER .....	3-10
GEAR OIL .....	3-10
SPARK PLUG .....	3-11
ENGINE MOUNTING BOLTS AND FLYWHEEL NUT .....	3-13
START-IN-GEAR PROTECTION ADJUSTMENT .....	3-13
IDLE SPEED ADJUSTMENT .....	3-13
IGNITION TIMING ADJUSTMENT .....	3-14
THROTTLE CONTROL LINK ADJUSTMENT .....	3-16
GREASING POINTS .....	3-17



**PREDELIVERY SERVICE  
CONTENTS**

Item	Refer to page
1. Electrical wiring	3-2 ~ 3-3
2. Fuel line	3-4
3. Gear oil level	3-5
4. Operation of controls and moving parts	3-5
5. Fuel leakage	3-6
6. Water leakage	3-6
7. Exhaust leakage	3-6
8. Engine and lower unit noise	3-6
9. Idle-speed	3-6
10. Ignition timing	3-6
11. Motor exterior	3-6
12. Instructing the new owner	3-6

**ELECTRICAL WIRING**

8CM	✓	8CEM	
8CM	✓	8CEM	

- ① C.D.I. unit
- ② Ignition coil
- ③ Rectifier regulator\*
- ④ 2P connector\*
- ⑤ Engine stop switch

- B : Black
- Br : Brown
- G : Green
- G/W : Green/White
- O : Orange
- R : Red
- W : White
- W/R : White/Red

\* For Europe model

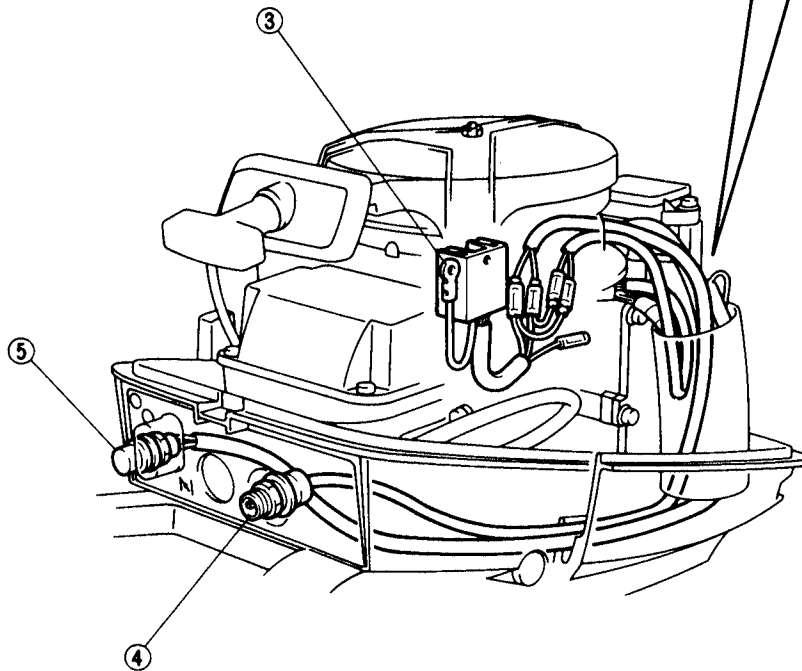
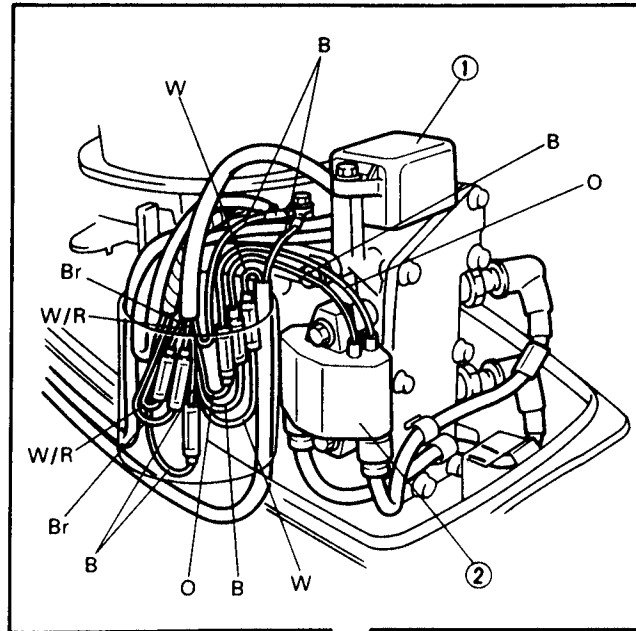



6CM	6CEM	✓
8CM	8CEM	✓

- |                      |                   |
|----------------------|-------------------|
| ① C.D.I. unit        | B : Black         |
| ② Ignition coil      | Br : Brown        |
| ③ Neutral switch     | G : Green         |
| ④ Starter switch     | G/W : Green/White |
| ⑤ Engine stop switch | O : Orange        |
| ⑥ Battery            | R : Red           |
| ⑦ Starter motor      | W : White         |
| ⑧ Fuse               | W/R : White/Red   |
| ⑨ Starter relay      |                   |
| ⑩ Rectifier          |                   |

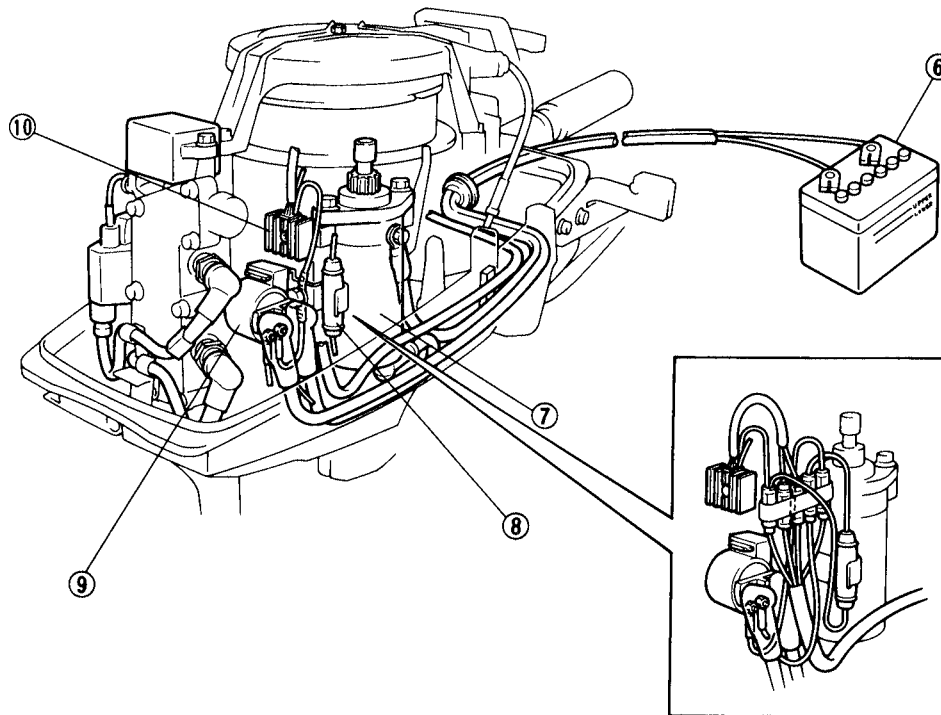
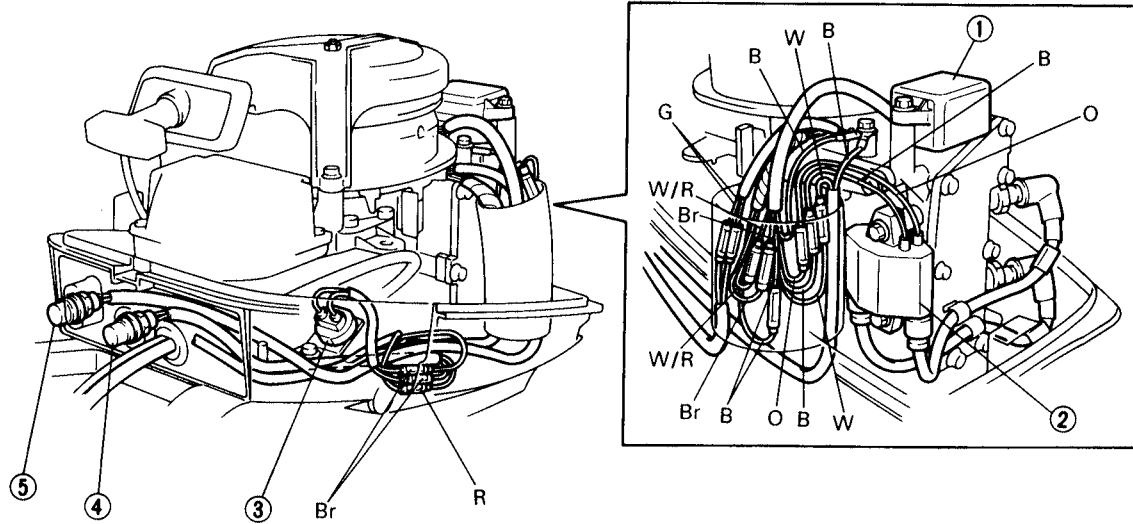



**FUEL LINE**

- ① Carburetor
- ② Fuel hose
- ③ Fuel strainer
- ④ Hose joint

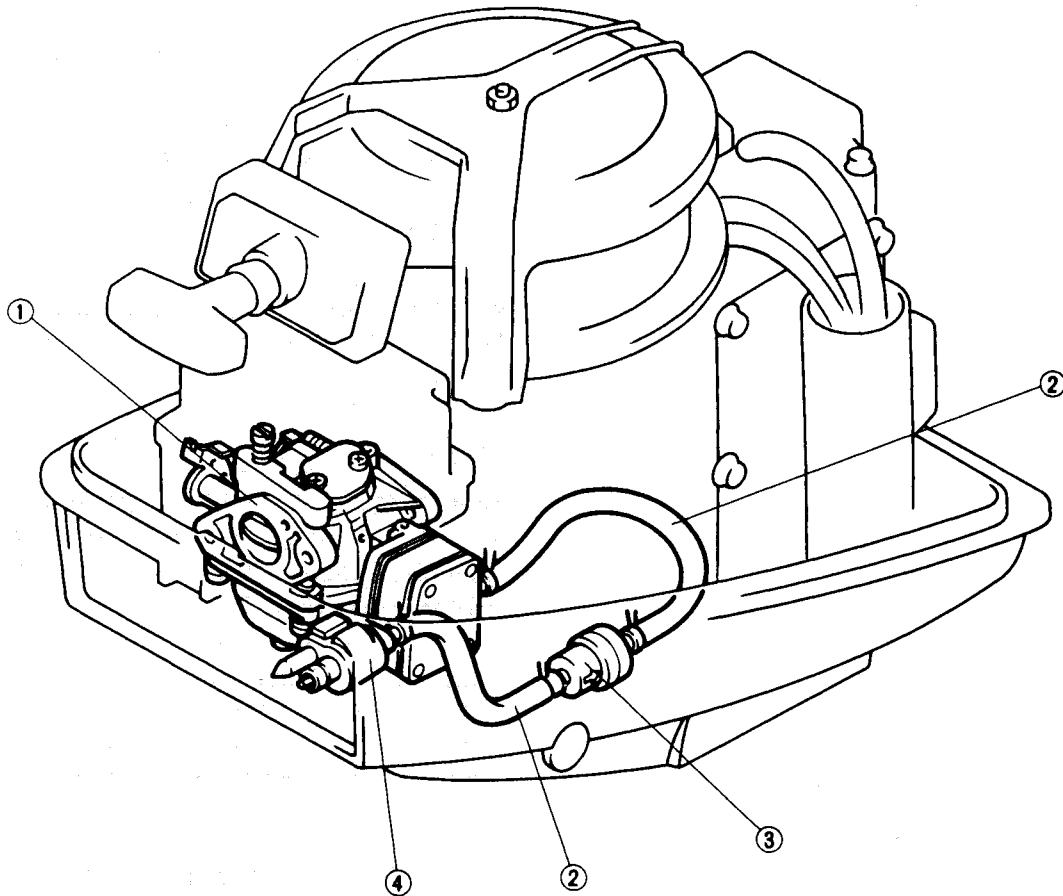

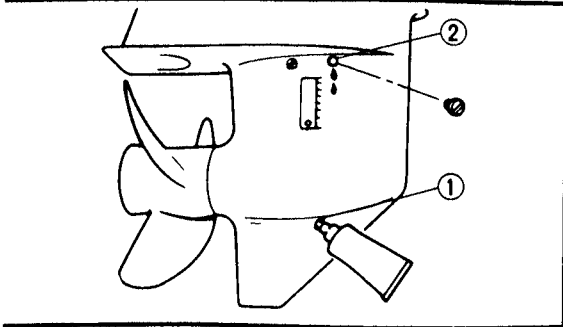

D23000-0

**GEAR OIL LEVEL**

Remove the oil-drain ① and oil-level ② plugs, and add the gear oil through the oil-drain hole until it overflows from the oil-level hole. Refit the plugs. (The oil level plug first.)

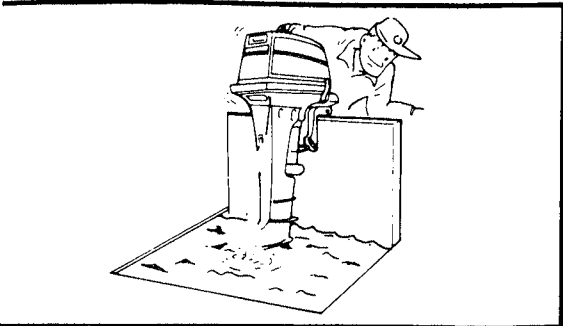

**OPERATION OF CONTROLS AND MOVING PARTS**

1. Check shift control for normal operation.
2. Check steering control for smooth operation.
3. Check throttle control for smooth operation.
4. Check ignition timing for normal operation.
5. Check cowling lock and release mechanism for normal operation.
6. Check starting system for normal operation.

**CAUTION**

Use a 25:1 fuel mixture to start the engine.

**WARNING**

Before attempting to check the starting system, replace the propeller with the specified test propeller, and install the motor in a test tank.



**Test propeller:**  
**/90890-01625**

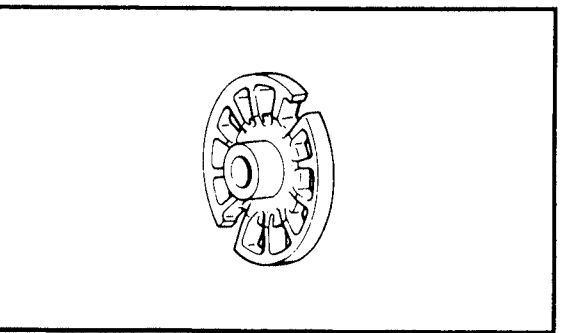

7. Check for normal operation of the engine stop system.

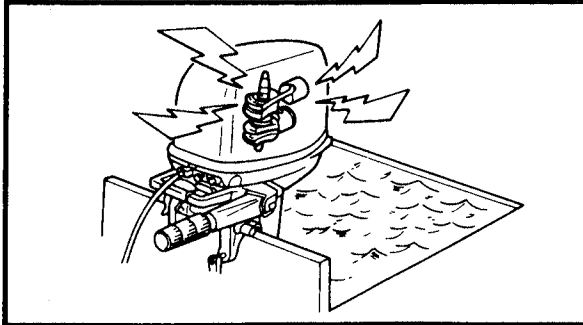

D24500-0

**FUEL LEAKAGE**

Check for fuel leakage.

D25000-0

**WATER LEAKAGE**

Check for water leakage.

D25500-0

**EXHAUST LEAKAGE**

Check for exhaust leakage.

D26000-0

**ENGINE AND LOWER UNIT NOISE**

Check the engine and lower unit for abnormal noise.

D26500-0

**IDLE-SPEED**

Check that the engine speed at fully-closed throttle is correct.

D27000-0

**IGNITION TIMING**

Check that the ignition timing at fully-closed and fully-open throttle positions is correct.

D27500-0

**MOTOR EXTERIOR**

Check the motor exterior for any flaking of the paint, and if necessary touch-up with paint of the original color.

D28000-1

**INSTRUCTING THE NEW OWNER**

Instruct the new owner on the operation of all controls and the break-in procedure. Also advise him on propeller-to-boat matching.



## PERIODIC SERVICE

D30000-0

### PERIODIC SERVICE MAINTENANCE SCHEDULE

The following chart may be taken as a helpful guide to the intervals between maintenance procedures.

Item	Remarks	Interval			Thereafter every		Refer page
		10 hours (Break-in)	50 hours 3 months	100 hours 6 months	100 hours 6 months	200 hours 12 months	
Anode	Inspection/ Replacement	○	○	○	○		3-8
Battery	Inspection	○					3-9
Bolts and nuts	Retightening	○		○	○		-
Carburetor	Inspection/ Adjustment	○		○	○		-
Cooling water passage	Cleaning		○	○	○		-
Cotter-pin	Inspection/ Replacement		○	○	○		-
Fuel strainer	Inspection/ Replacement				○		3-10
Fuel line	Inspection			○	○		3-10
Fuel tank	Cleaning					○	-
Gear oil	Replacement	○		○	○		3-10
Greasing points	Greasing			○	○		3-17
Idle speed	Adjustment			○	○		3-13
Ignition timing	Inspection/ Adjustment	○		○	○		3-14
Outboard motor body	Inspection		○	○	○		-
Propeller	Inspection/ Retightening		○	○	○		3-8
Spark plug	Cleaning/ Adjustment	○	○	○	○		3-11
Start-in-gear protection	Adjustment	○		○	○		3-13
Throttle link	Adjustment	○		○	○		3-16

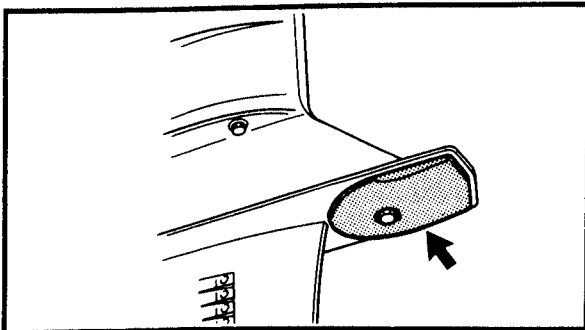

**ANODE**

1. Inspect:
- Anode
- Wear/Damage → Replace.

**CAUTION:** \_\_\_\_\_  
**Do not paint the anode, or the outboard may be corroded.**

---

2. Clean:
- Anode
- Use a wire brush.

**NOTE:** \_\_\_\_\_  
Remove all trace of oil or grease. After cleaning, polish the contact surfaces of the anode mount, and re-install.

---

**CAUTION:** \_\_\_\_\_  
**Never paint the anode. To sure good electrical contact, keep the anode contact surface clean of oil or grease.**

---

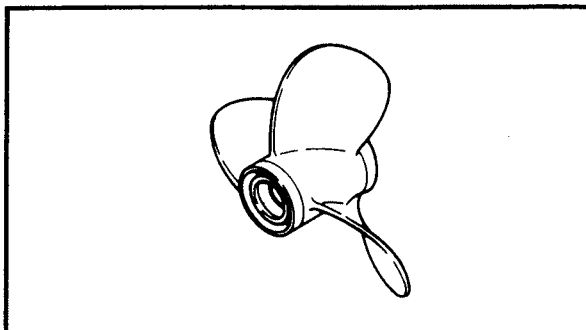

**PROPELLER**

1. Inspect:
- Propeller
  - Spline
- Wear/Cracks/Damage → Replace.



**BATTERY**

6CM	6CEM	✓
8CM	8CEM	✓

**⚠ WARNING**

Battery electrolyte is poisonous and dangerous, causing severe burns, etc. It contains sulfuric acid. Avoid contact with skin, eyes, or clothing.

**Antidote:**

**EXTERNAL; Flush with water.**

**INTERNAL; Drink large quantities of water or milk. Follow with milk of magnesia, beaten egg, or vegetable oil. Call physician immediately.**

**EYES; Flush with water for 15 minutes and get prompt medical attention.**

**Batteries produce explosive gases: Keep sparks, flame, cigarettes, etc. away. Ventilate when charging or using in a closed space. Always wear eye protection when working near batteries.**

**KEEP OUT OF REACH OF CHILDREN.**

---

**NOTE:**

- Batteries vary among manufacturers. Therefore the following procedures may not always apply. Consult your battery manufacturer's instructions.
  - Disconnect the black negative lead first to prevent the risk of shorting.
- 

**1. Inspect:**

- Battery fluid level
- Battery fluid specific gravity

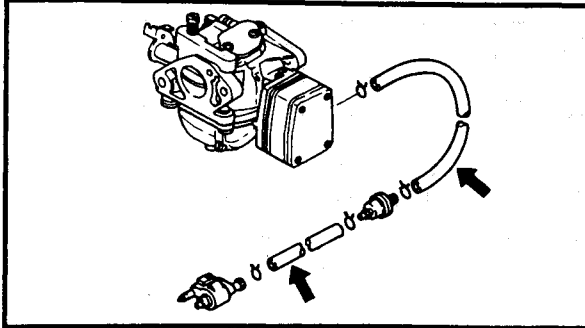

**FUEL LINE**

1. Inspect:

- Fuel line  
Crack/Leak/Damage → Replace.

**FUEL STRAINER**

Refer to page 4-2.

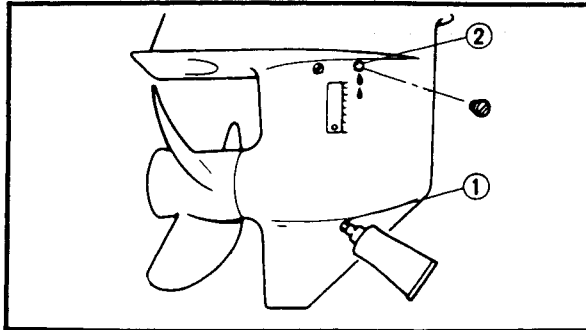

**GEAR OIL**

1. Check:

- Gear oil level  
Oil level is low → Add oil to proper level.

**Checking steps:**

- Place the outboard motor in an upright position.
- Remove the oil-drain ① and oil-level ② plugs.
- Add the gear oil through the oil drain hole until it over flows from the oil level hole.



**Recommended oil:**  
**GEAR CASE LUBE (USA) or**  
**Hypoid gear oil (SAE #90)**

- Install the oil level plug.
- Install the oil drain plug.

2. Check:

- Gear oil  
Dirt → Replace.

**Replacement steps:**

- Place the outboard motor in an upright position.
- Place a suitable container under the outboard motor.
- Remove the oil drain and level plugs.
- Drain the gear oil.
- Fill the gear oil.



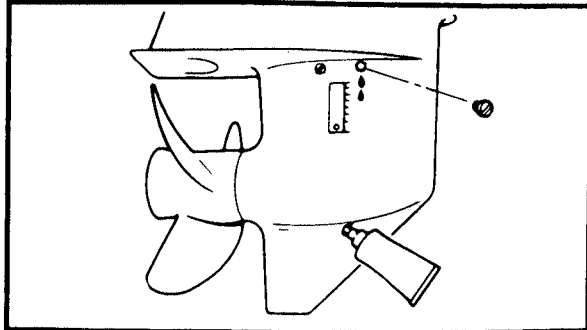

**Recommended oil:**  
**GEAR CASE LUBE (USA) or**  
**Hypoid gear oil (SAE #90)**  
**Oil capacity:**  
**160 cm<sup>3</sup>**  
**(5.41 US oz, 5.63 Imp oz)**

- Check the gear oil level.
- Install the oil level plug.
- Install the oil drain plug.

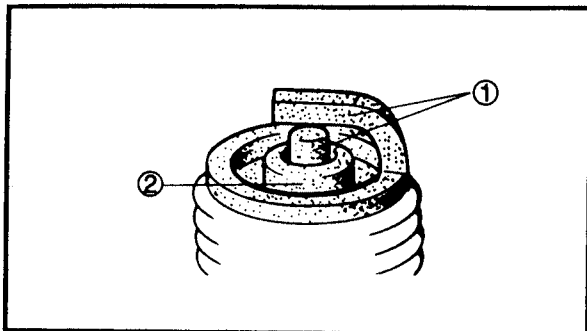

**SPARK PLUG**

1. Remove:
  - Spark plug
2. Inspect:
  - Electrode ①  
Wear/Damage → Replace.
  - Insulator color ②  
Normal condition is a medium to light tan color.  
Distinctly different color → Check the engine condition.  
White color: Lean fuel mixture
    - Plugged filter, jet
    - Air leak
    - Wrong setting
 Blackish color: Electrical malfunction
    - Defective spark plug
    - Excess oil used
3. Clean:
  - Spark plug  
Clean the spark plug with a spark plug cleaner or wire brush.



4. Inspect:

- Spark plug type  
Incorrect → Replace.



**Standard spark plug:**  
**NGK B7HS-10**  
**NGK BR7HS-10**  
(noise suppressor type)

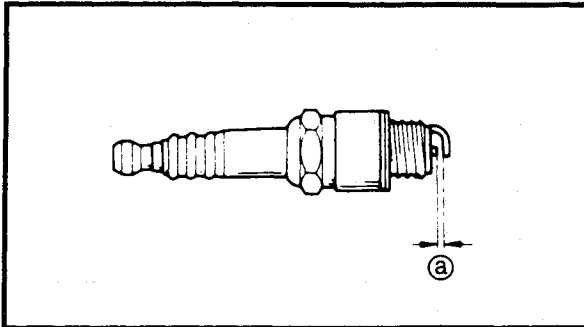

5. Measure:

- Spark plug gap ①  
Out of specification → Adjust.  
Use a wire gauge.



**Spark plug gap:**  
**0.9 ~ 1.0 mm (0.035 ~ 0.039 in)**

6. Tighten:

- Spark plug

**NOTE:**

Before installing a spark plug, clean the gasket surface and plug surface. Also it is suggested to apply a thin film of Anti Seize Compound to the spark plug threads to prevent future thread seizure.

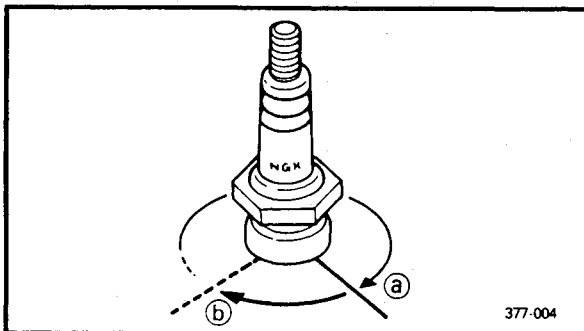

**Spark plug:**  
**25 Nm (2.5 m · kg, 18 ft · lb)**

**NOTE:**

If a torque wrench is not available when you are installing a spark plug, a good estimate of the correct torque is 1/4 to 1/2 turns ② part finger tight ①. Have the spark plug torqued to the correct value as soon as possible with a torque wrench.

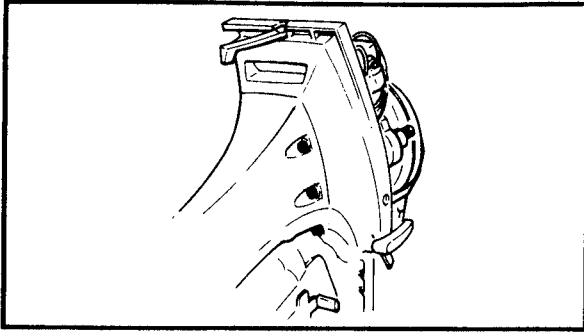

**ENGINE MOUNTING BOLTS AND FLYWHEEL NUT**

1. Check:
  - Engine mounting bolt
  - Flywheel nut
 Loosen → Tighten.

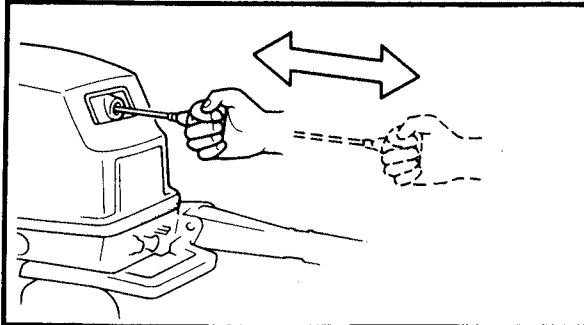

**START-IN-GEAR PROTECTION ADJUSTMENT**

1. Check:
  - Start-in-gear protection operation
 Incorrect → Adjust.
2. Adjust:
  - Start-in-gear protection wire

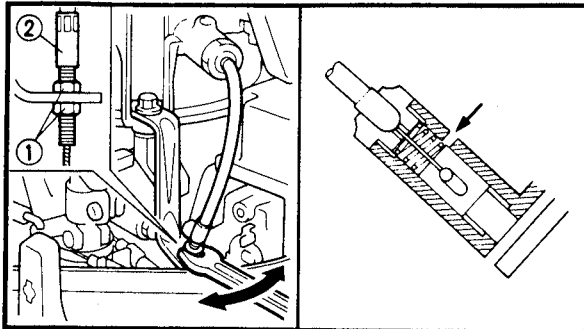

**Adjustment steps:**

- Set the shift lever to neutral.
- Loosen the lock nut ①.
- Adjust the start-in-gear protection wire adjust bolt ② so that the end of the starter stop-plunger aligns with the center of the hole in the starter case.
- Tighten the lock nut.

**IDLE SPEED ADJUSTMENT**

**NOTE:** \_\_\_\_\_  
After adjusting the engine idle speed, the throttle control link should be adjusted.

1. Measure:
  - Idle speed
 Out of specification → Adjust.

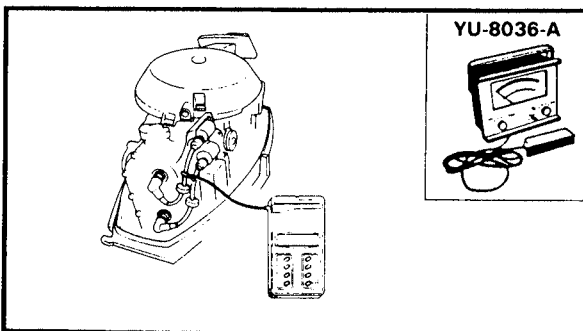

	<b>Idle speed:</b> <b>900 ± 50 rpm</b>
--	---

<b>Measuring steps:</b>	
<ul style="list-style-type: none"> <li>● Start the engine and let it warm up.</li> <li>● Attach the tachometer to spark plug lead.</li> </ul>	

	<b>Tachometer:</b> <b>YU-8036-A/90890-06760</b>
--	--

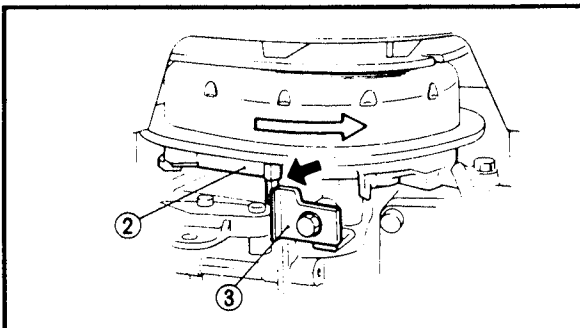
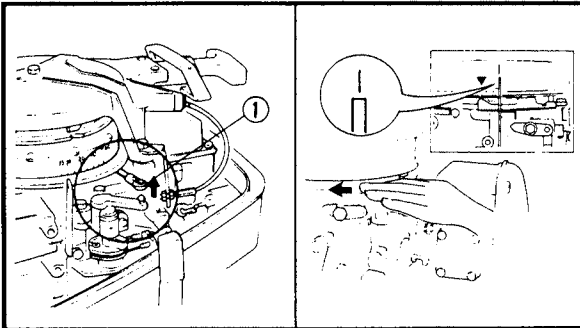
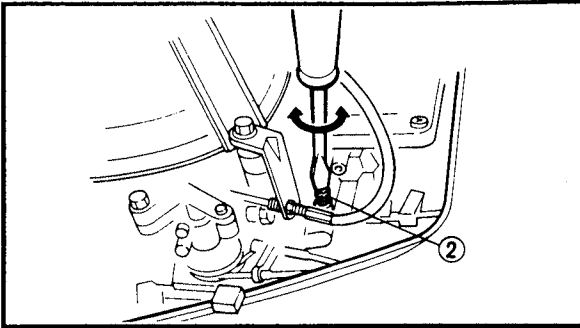
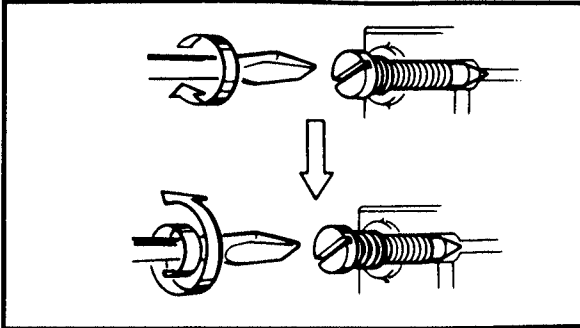
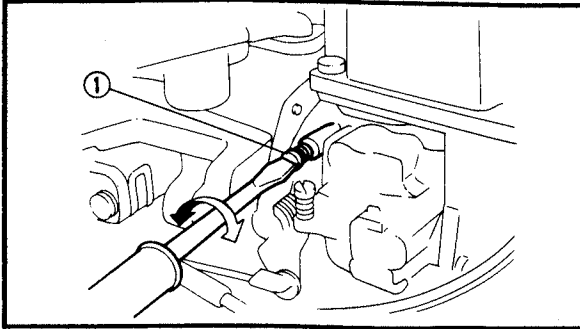

2. Adjust:
- Idle speed

**Adjustment steps:**

- Turn the pilot screw ① until it is lightly seated.
- Turn the pilot screw outward to specification.



**Pilot screw:**  
1-1/8 ± 1/4 turns out

- Start the engine, and allow it to warm up for a few minutes.
- Turn the throttle stop screw ② in or out until specified idle speed is obtained.

**Turning in → Idle speed becomes higher.**

**Turning out → Idle speed becomes lower.**

**IGNITION TIMING ADJUSTMENT**

1. Check:
- Ignition timing (at full advanced)  
Incorrect → Adjust.

**Checking steps:**

- Disconnect the joint link ①.
- Slowly turn the flywheel clockwise.
- Align the timing plate with specification on the flywheel indicator.



**Ignition timing (at full advanced):**  
B.T.D.C. 35 ± 1°

- Align the marks on the magneto base and flywheel by turning the magneto base.
- Check the magneto base ② to contact the stopper plate ③.

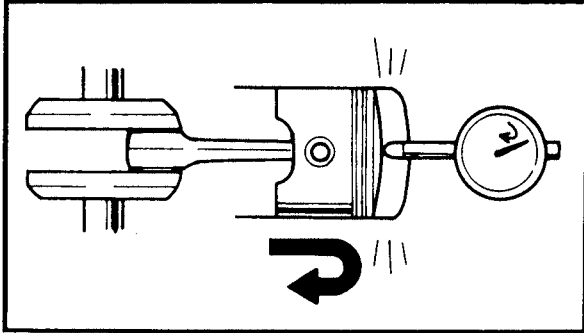

2. Adjust:

- Ignition timing (at full advanced)

**Adjustment steps:**

- Remove the spark plugs.
- Attach the dial gauge in the spark plug hole of No. 1 (upper) cylinder.



**Dial gauge:**

**YU-3097/90890-01252**

**Dial gauge stand:**

**YU-1256**

- Slowly turn the flywheel clockwise, and stop it when the piston is at TDC.

**CAUTION:**

Be sure to turn the flywheel clockwise, or the impeller blade will be twisted the other way, thus reducing pump performance.

- Set the timing plate at TDC.
- Turn the flywheel to align the timing plate ① with specification on the flywheel indicator.

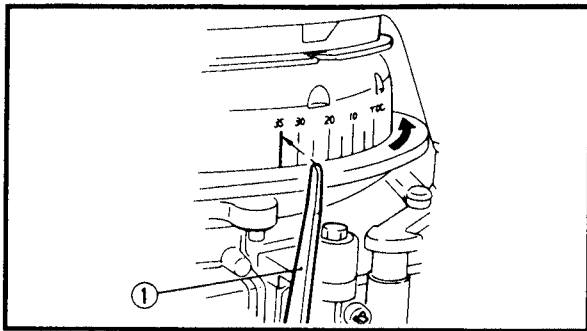

**Ignition timing (at full advanced):**

**B.T.D.C.  $35 \pm 1^\circ$**

- Loosen the stopper plate set-bolt ②.
- Align the marks on the magneto base ③ and flywheel ④ by turning the magneto base.
- Adjust the stopper plate so that it to contact with the magneto base stopper ⑤.

**NOTE:**

Press the stopper plate against the full-advanced side of the magneto base.

- Tighten the stopper plate set-bolt.
- Connect the joint link.

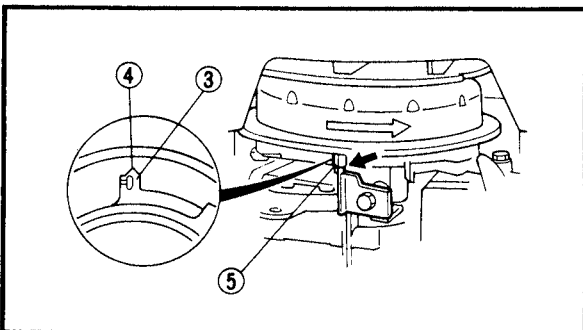
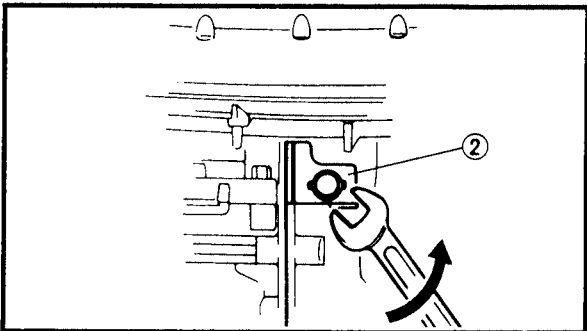

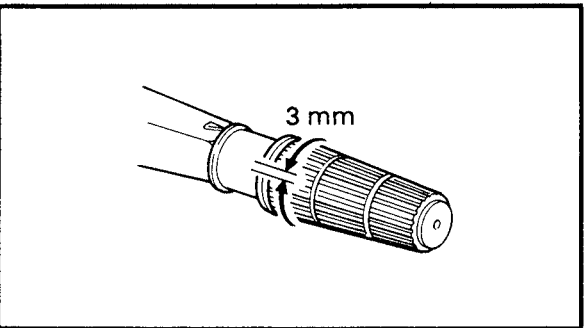
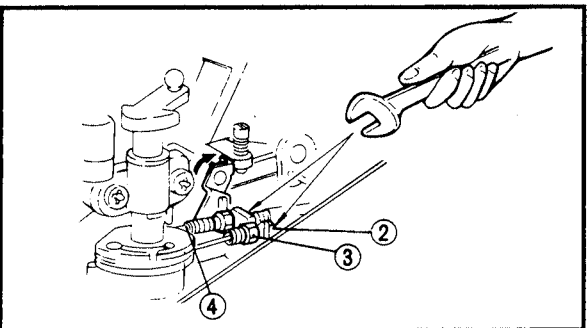
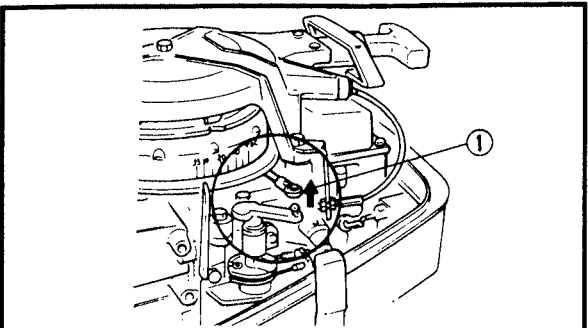
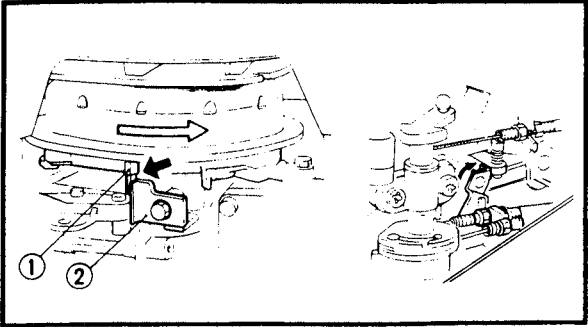
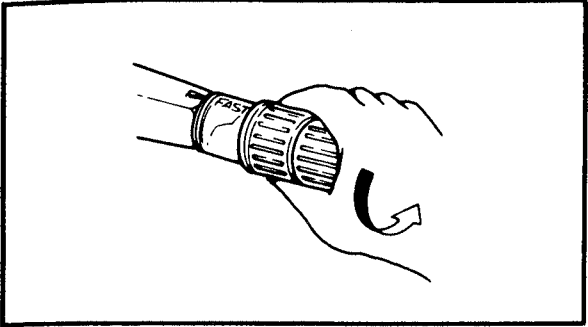

**THROTTLE CONTROL LINK  
ADJUSTMENT**

**NOTE:** \_\_\_\_\_  
Before adjusting the throttle control link, the ignition timing should be adjusted.

1. Check:
- Full-open position  
Incorrect → Adjust.

**Checking steps:**

- Set the shift lever to forward position.
- Fully open the throttle grip.
- Check the magneto base stopper ① so that it contacts with the stopper plate ②.
- Check the throttle valve in full-opened.

2. Adjust:
- Throttle control link

**Adjustment steps:**

- Remove the joint link ①.
- Set the shift lever to forward position.
- Bring the stopper on the full-advanced side of the magneto base to contact the magneto base stopper.
- Fully open the throttle grip.
- Adjust the cable adjuster on the "pull" throttle cable ② until to fully-open the carburetor throttle valve.
- Tighten the lock nut ③ on the "pull" throttle cable.
- Adjust the cable adjuster on the "push" throttle cable ④ until there is 3 mm (0.12 in) free play on the throttle grip.
- Tighten the lock nut.

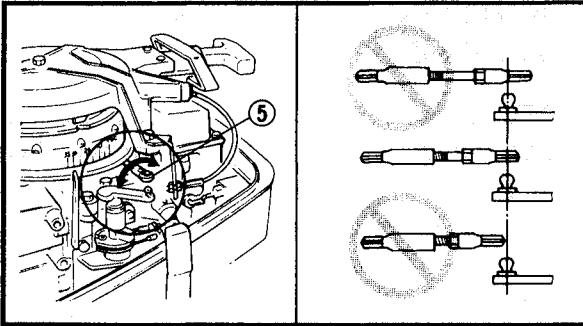

- Adjust the length of the joint link ⑤ so that the control lever comes to contact with the magneto base.
- Connect the joint link.
- Check the throttle valve to fully open position.

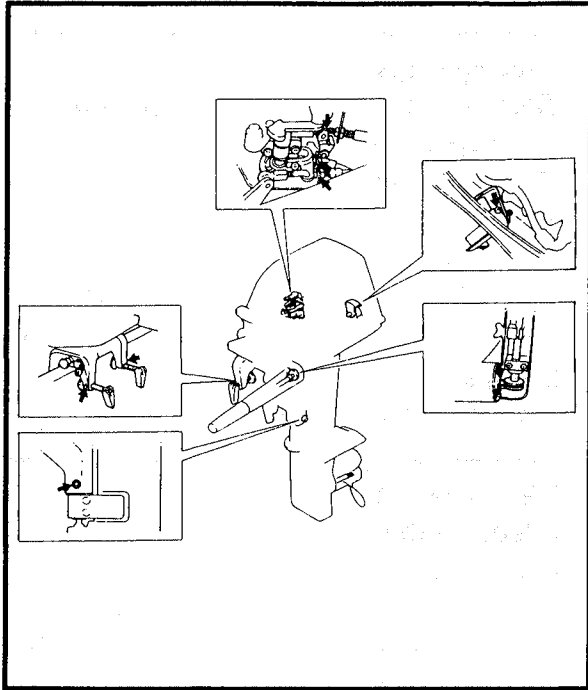

**GREASING POINTS**

1. Apply:
  - Water resistant grease

## CHAPTER 4 FUEL SYSTEM

<b>FUEL SYSTEM</b> .....	4-1
<b>PREPARATION FOR REMOVAL</b> .....	4-1
<b>INSPECTION</b> .....	4-2
Fuel joint.....	4-2
Fuel strainer .....	4-2
<b>ASSEMBLY AND INSTALLATION</b> .....	4-2
Fuel strainer .....	4-2
Fuel joint.....	4-3
<b>CARBURETOR</b> .....	4-4
<b>PREPARATION FOR REMOVAL</b> .....	4-4
<b>NOTE ON REMOVAL AND REASSEMBLY</b> .....	4-5
<b>REMOVAL POINTS</b> .....	4-5
Float.....	4-5
<b>INSPECTION</b> .....	4-6
Carburetor body .....	4-6
Pilot screw.....	4-6
Jet and nozzle .....	4-6
Needle valve .....	4-6
Float.....	4-6
<b>ASSEMBLY AND INSTALLATION</b> .....	4-7
Fuel pump .....	4-7
Carburetor .....	4-7



E20050-0

**FUEL SYSTEM  
PREPARATION FOR REMOVAL**

- Remove the top cowling.

**⚠ WARNING**

- Petrol (gasoline) is highly inflammable and explosive. Handle with special care.
- Failure to check for fuel leakage may result in fire or explosion.

**A** 3 Nm (0.3 m • kg, 2.2 ft • lb)

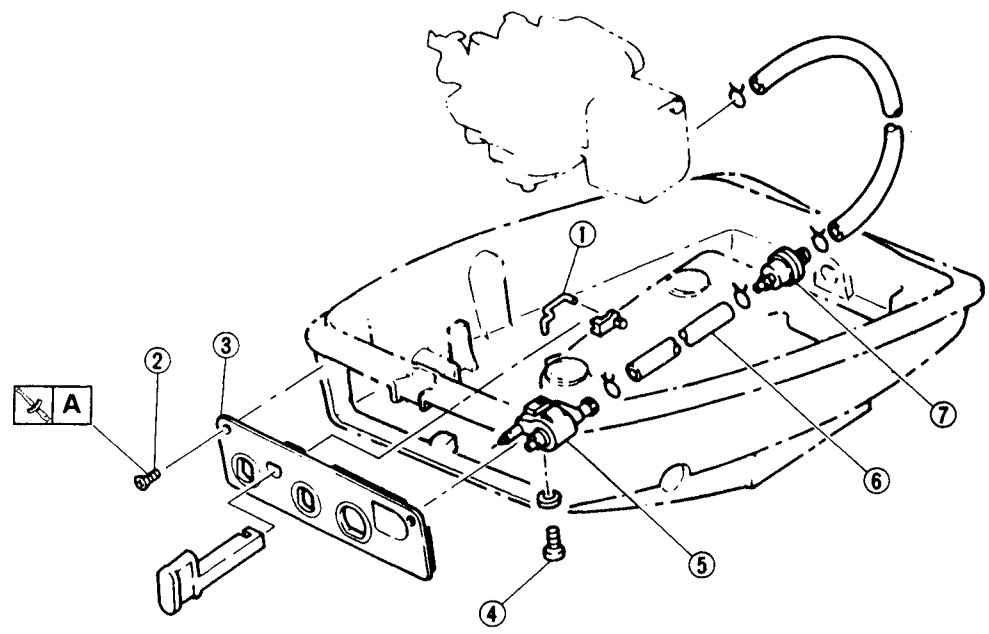

Extent of removal: ① Front panel removal ② Fuel joint removal  
③ Fuel strainer removal

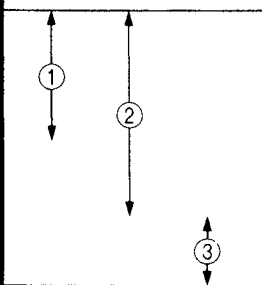
Extent of removal	Order	Part name	Q'ty	Remarks
	1	Choke joint	1	Disconnect the joint at carburetor side.
	2	Screw	3	
	3	Front panel	1	
	4	Bolt	1	
	5	Fuel joint	1	Disconnect the fuel hose.
	6	Fuel hose	1	
	7	Fuel strainer	1	

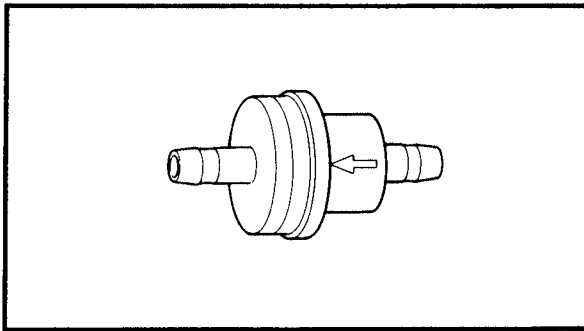
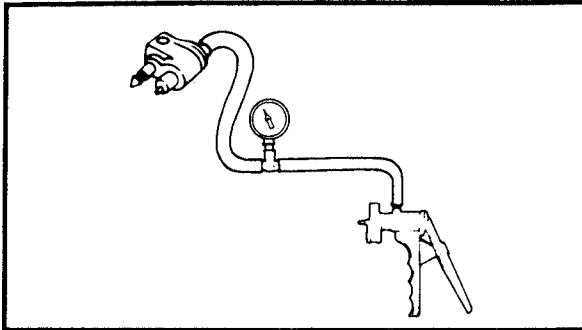
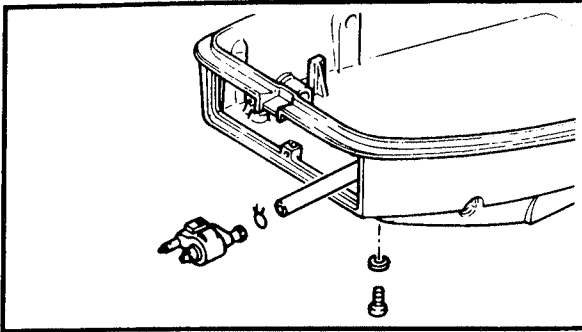

E21850-0

**INSPECTION**

**Fuel joint**

1. Inspect:
  - Fuel joint  
Crack/Leak/Damage → Replace.
2. Measure:
  - Fuel joint operation  
Impossible to maintain the specified pressure for 10 sec. → Replace.

**Measuring steps:**

- Attach the Mity vac.



**Mity vac:**  
YB-35956/90890-06756

- Apply the specified pressure.



**Specified pressure:**  
50 kPa (0.5 kg/cm<sup>2</sup>, 7.1 psi)

**Fuel strainer**

1. Inspect:
  - Fuel strainer  
Crack/Leak/Clog → Replace.

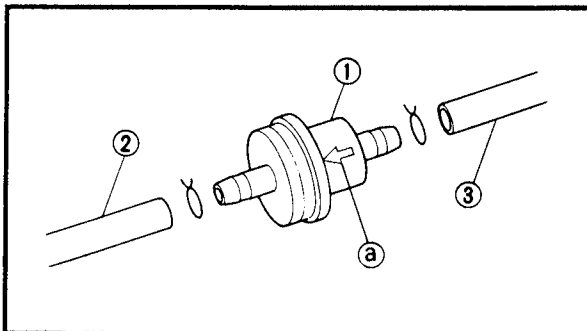

E22050-0

**ASSEMBLY AND INSTALLATION**

**Fuel strainer**

1. Install:
  - Fuel strainer ①
  - Fuel hose ② (to carburetor)
  - Fuel hose ③ (from fuel joint)

**NOTE:** \_\_\_\_\_

The direction mark ④ should be installed facing to the carburetor.

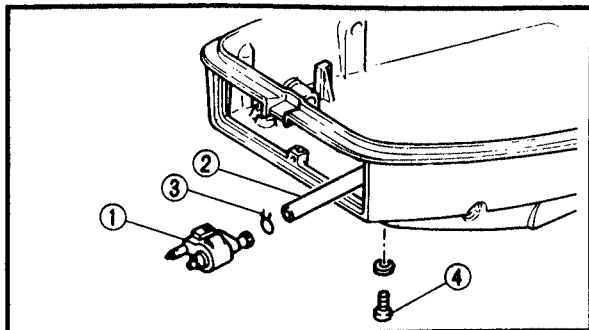
**Fuel joint****1. Install:**

- Fuel joint ①
- Fuel hose ② (to fuel filter)
- Clip ③
- Bolt ④

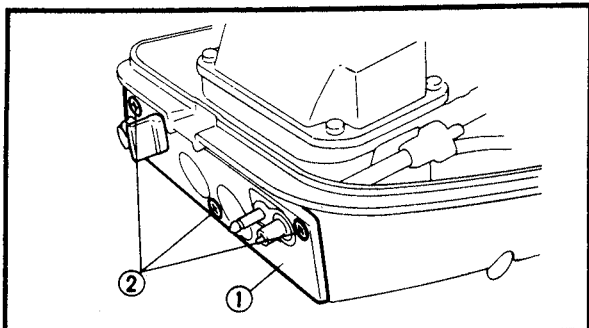
**2. Install:**

- Front panel ①
- Screw ②



**Screw:**  
3 Nm (0.3 m · kg, 2.2 ft · lb)

**3. Connect:**

- Choke joint

**NOTE:** \_\_\_\_\_

After installing, check the smooth movement of the choke knob.

---

**4. Check:**

- Fuel line  
Leak → Repair.



# CARBURETOR

E20050-0

## CARBURETOR PREPARATION FOR REMOVAL

- Remove the top cowling.
- Remove the front panel.

### **⚠ WARNING**

- Petrol (gasoline) is highly inflammable and explosive. Handle with special care.
- Failure to check for fuel leakage may result in fire or explosion.

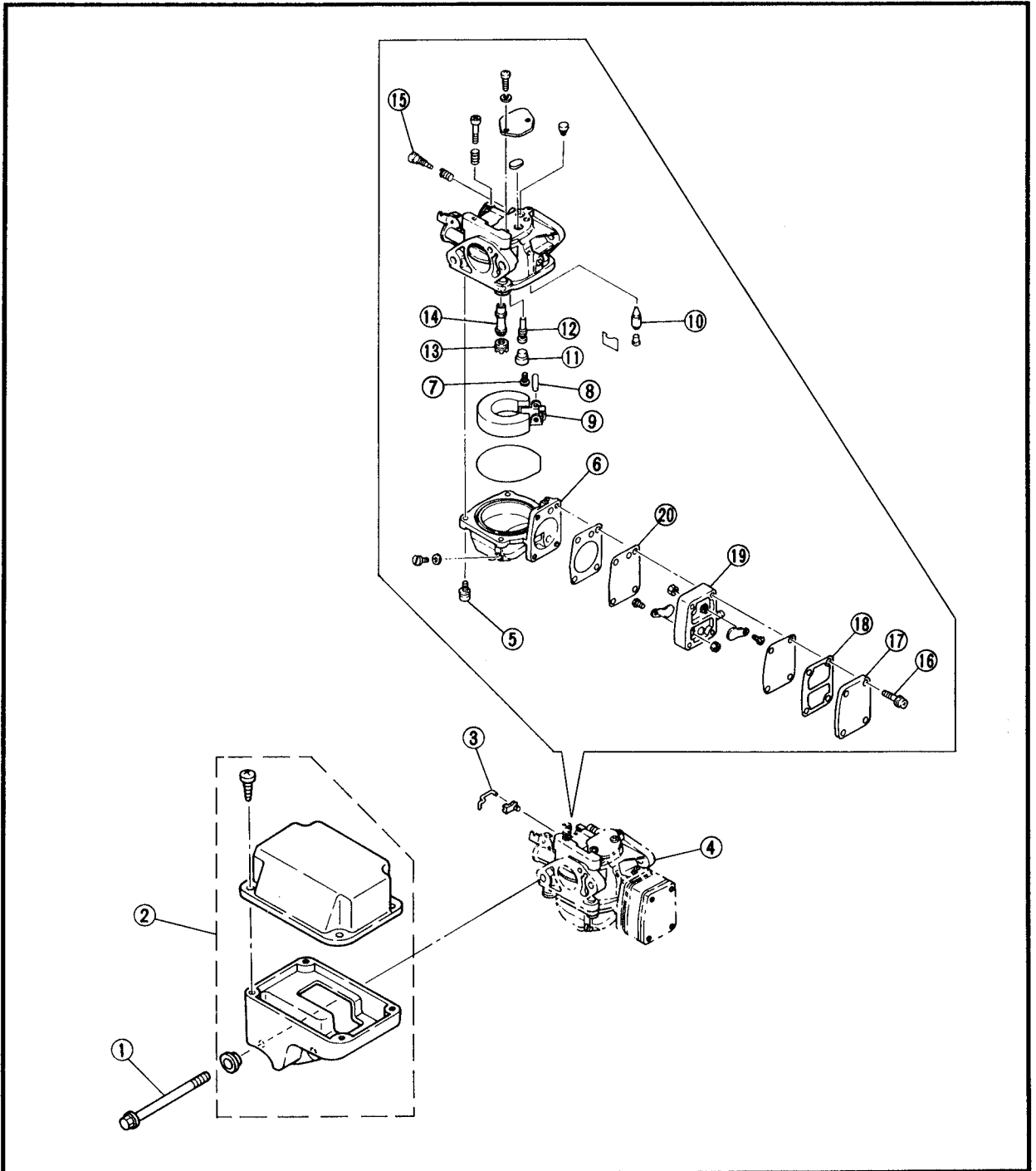



E31150-0

**NOTE ON REMOVAL AND REASSEMBLY**

- With the engine mounted, the following parts can be removed.
- Before inspection, the removed parts should be cleaned and blow out all passages and jets with compressed air.
- After removing the carburetor, cover the carburetor joint not to enter foreign material.

Extent of removal: ① Carburetor removal    ② Carburetor disassembly  
 ③ Fuel pump disassembly

Extent of removal	Order	Part name	Q'ty	Remarks
	1	Bolt	2	Refer to REMOVAL POINTS.
	2	Intake silencer	1	
	3	Choke rod	1	
	4	Carburetor	1	
	5	Screw	4	
	6	Float chamber body	1	
	7	Screw	1	
	8	Float pin	1	
	9	Float	1	
	10	Needle valve	1	
	11	Cap	1	
	12	Pilot jet	1	
	13	Main jet	1	
	14	Main nozzle	1	
	15	Pilot screw	1	
	16	Screw	4	
	17	Body (outer)	1	
	18	Diaphragm	1	
	19	Body (inner)	1	
	20	Diaphragm	1	

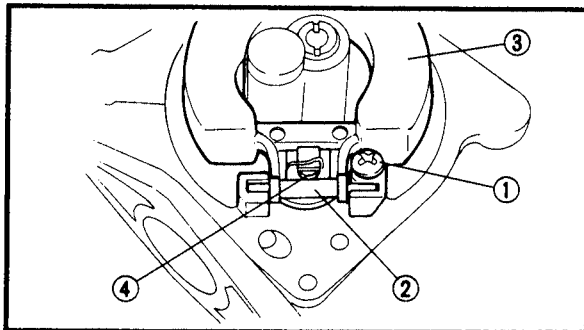

**REMOVAL POINTS**

**Float**

1. Remove:
- Screw ①
  - Float pin ②
  - Float ③
  - Needle valve ④

**NOTE:** \_\_\_\_\_  
 The needle valve is removed together with the float.

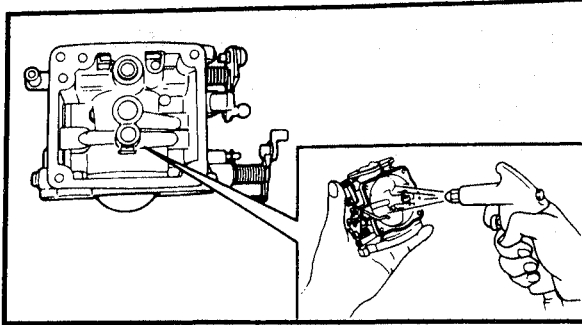

E32050-0

**INSPECTION**

**Carburetor body**

1. Inspect:

- Carburetor body
- Crack/Damage → Replace.
- Contamination → Clean.

**NOTE:**

- Use a petroleum based solvent for cleaning. Blow out all passages with compressed air.
- Do not use a wire.

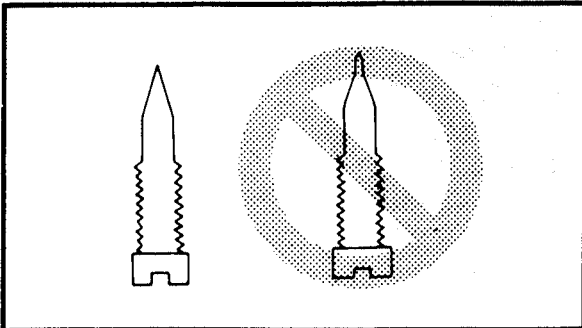

E32052-0

**Pilot screw**

1. Inspect:

- Pilot screw
- Bend/Wear → Replace.

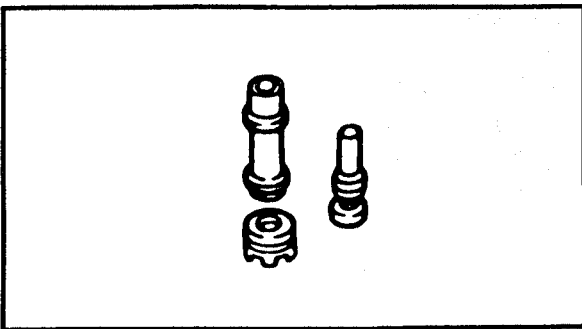

E32054-0

**Jet and nozzle**

1. Inspect:

- Main jet
- Pilot jet
- Main nozzle
- Contamination → Replace.

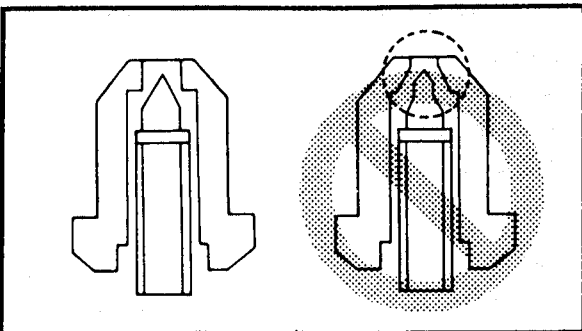

E32056-0

**Needle valve**

1. Inspect:

- Needle valve
- Grooved wear → Replace.

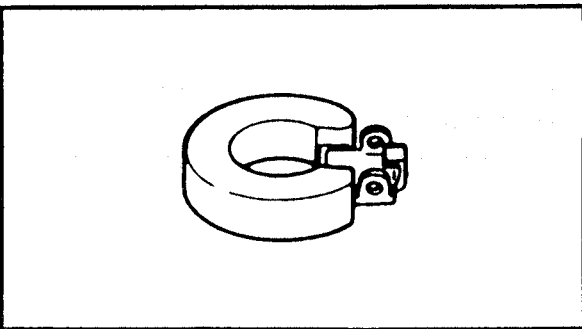

E32058-0

**Float**

1. Inspect:

- Float
- Crack/Damage → Replace.



E34050-0

**ASSEMBLY AND INSTALLATION**

**Fuel pump**

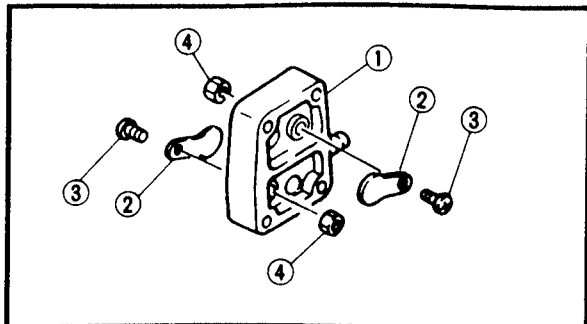

1. Install:

- Body ① (inner)
- Check valve ②
- Screw ③
- Nut ④

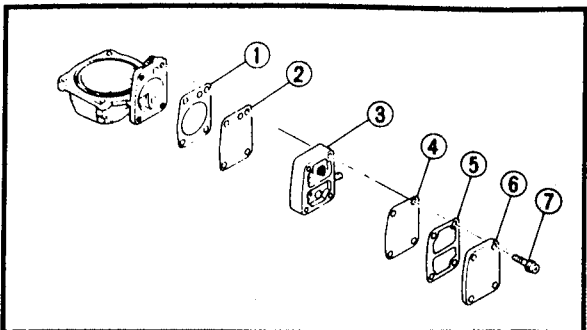

2. Install:

- Gasket ①
- Diaphragm ②
- Body ③ (inner)
- Gasket ④
- Diaphragm ⑤
- Body ⑥ (outer)
- Screw ⑦

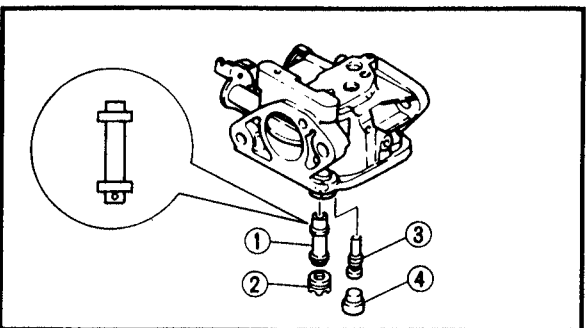

**Carburetor**

1. Install:

- Main nozzle ①
- Main jet ②
- Pilot jet ③
- Cap ④

**NOTE:**

Install the main nozzle by holding its end with a hole.

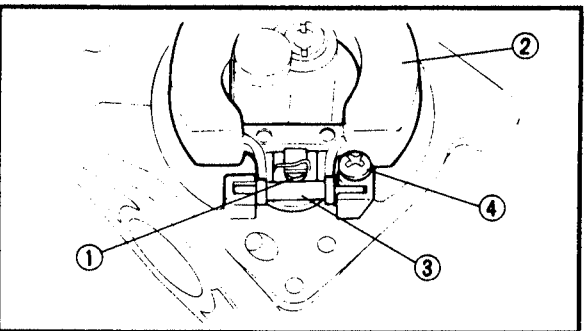

2. Install:

- Needle valve ①
- Float ②
- Float pin ③
- Screw ④

**NOTE:**

- The float pin should be fit in the slit the carburetor and locked with the screw.
- When installing the float in the carburetor, place the needle valve in the valve seat.
- After installing, check for smooth movement the float.

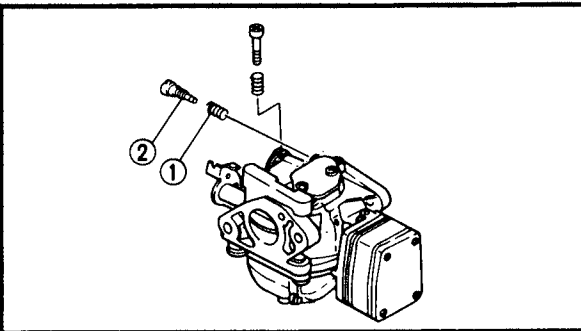
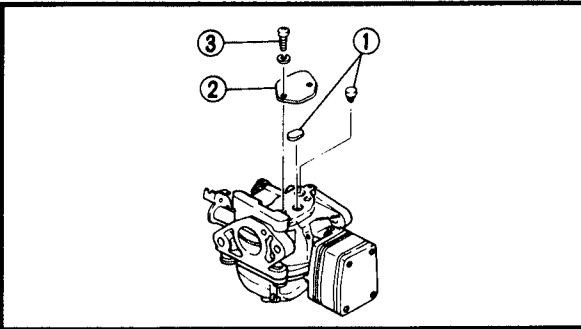
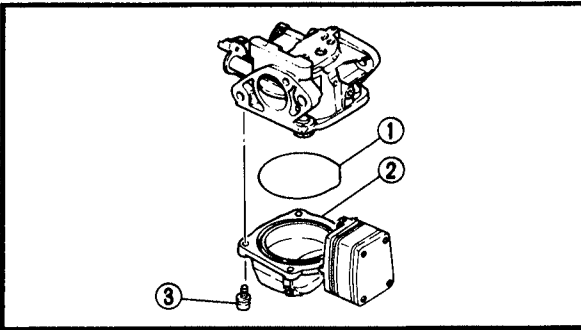
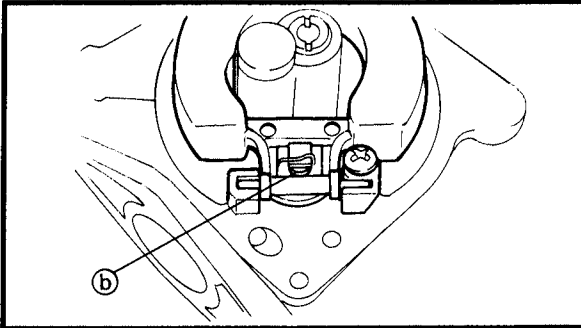
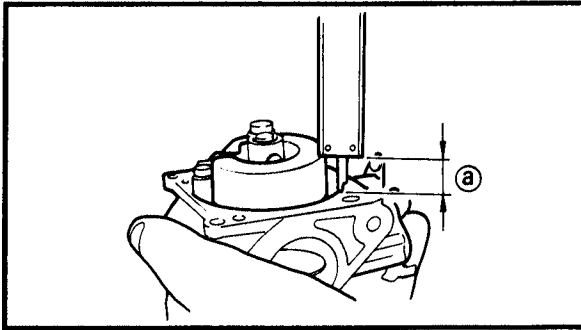

**3. Measure:**

- Float height ①
- Out of specification → Fold the tab ② to adjust float arm height.



**Float height:**  
 $14 \pm 2 \text{ mm (} 0.55 \pm 0.08 \text{ in)}$

**NOTE:**

- The float should be resting on the needle valve, but not compressing the needle valve.
- Take measurement at the end surface of the float opposite to its pivot side.

**4. Install:**

- O-ring ① (float chamber)
- Float chamber body ②
- Screw ③

**5. Install:**

- Gasket ① (mixing cover)
- Mixing cover ②
- Screw ③

**6. Install:**

- Spring ①
- Pilot screw ②



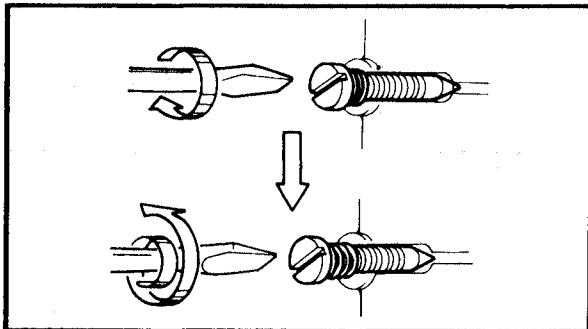

7. Adjust:

- Pilot screw

**Adjustment steps:**

- Screw in the pilot screw until it is lightly seated.
- Back out by the specified number of turns.



**Pilot screw:**

1-1/8 ± 1/4 (turns out)

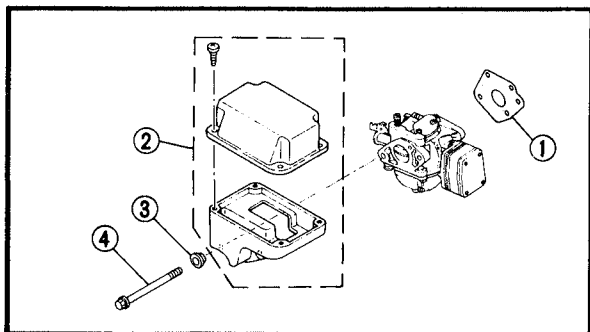

8. Install:

- Gasket ①
- Intake silencer ②
- Collar ③
- Bolt ④

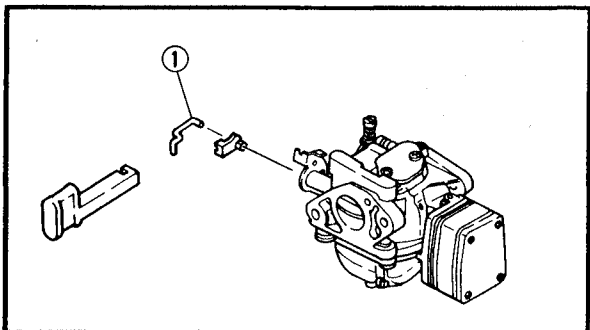

9. Install:

- Throttle link ①
- Fuel hose

10. Adjust:

- Idle speed
- Refer to page 3-13 ~ 3-14.

## CHAPTER 5 POWER UNIT

<b>POWER UNIT REMOVAL AND INSTALLATION .....</b>	<b>5-1</b>
<b>PREPARATION FOR REMOVAL .....</b>	<b>5-1</b>
<b>NOTE ON REMOVAL AND REASSEMBLY .....</b>	<b>5-2</b>
<b>REMOVAL POINTS.....</b>	<b>5-2</b>
Power unit.....	5-2
<b>ASSEMBLY AND INSTALLATION.....</b>	<b>5-3</b>
Power unit.....	5-3
<b>CYLINDER, PISTON AND CRANKSHAFT .....</b>	<b>5-5</b>
<b>PREPARATION FOR REMOVAL .....</b>	<b>5-5</b>
<b>NOTE ON REMOVAL AND REASSEMBLY .....</b>	<b>5-6</b>
<b>REMOVAL POINTS.....</b>	<b>5-6</b>
Flywheel magneto.....	5-6
Crankcase.....	5-7
Crankshaft and piston .....	5-8
Piston pin clip .....	5-8
Piston pin and small end bearing .....	5-8
Piston ring.....	5-8
Bearing.....	5-8
<b>INSPECTION AND REPAIR .....</b>	<b>5-9</b>
Thermostat.....	5-9
Flywheel magneto.....	5-9
Exhaust manifold.....	5-9
Exhaust cover .....	5-10
Oil seal housing.....	5-10
Reed valve.....	5-10
Cylinder body.....	5-11
Piston.....	5-12
Piston to cylinder clearance.....	5-13
Piston pin and small end bearing .....	5-13
Piston ring .....	5-14
Crankshaft .....	5-15
<b>ASSEMBLY AND INSTALLATION.....</b>	<b>5-16</b>
Bearing .....	5-16
Piston and piston ring .....	5-16
Crankshaft and piston .....	5-16
Oil seal housing.....	5-17
Reed valve assembly.....	5-17
Cylinder body and crankcase .....	5-18
Exhaust cover .....	5-19
Exhaust manifold.....	5-19
Cylinder head cover .....	5-19
Oil seal housing.....	5-20
Flywheel magneto.....	5-20

**RECOIL STARTER** ..... 5-23

**PREPARATION FOR REMOVAL** ..... 5-23

**REMOVAL POINTS**..... 5-24

        Sheave drum..... 5-24

        Spiral spring..... 5-24

**INSPECTION** ..... 5-25

        Drive pawl and spring ..... 5-25

        Bushing ..... 5-25

        Sheave drum..... 5-25

        Starter rope ..... 5-25

        Spiral spring..... 5-25

**ASSEMBLY AND INSTALLATION**..... 5-26

        Recoil starter ..... 5-26

E20050-0

**POWER UNIT REMOVAL AND INSTALLATION  
PREPARATION FOR REMOVAL**

- Remove the top cowling.
- Disconnect the wire leads.
- Remove the carburetor.
- Disconnect the throttle cables at the lever side.

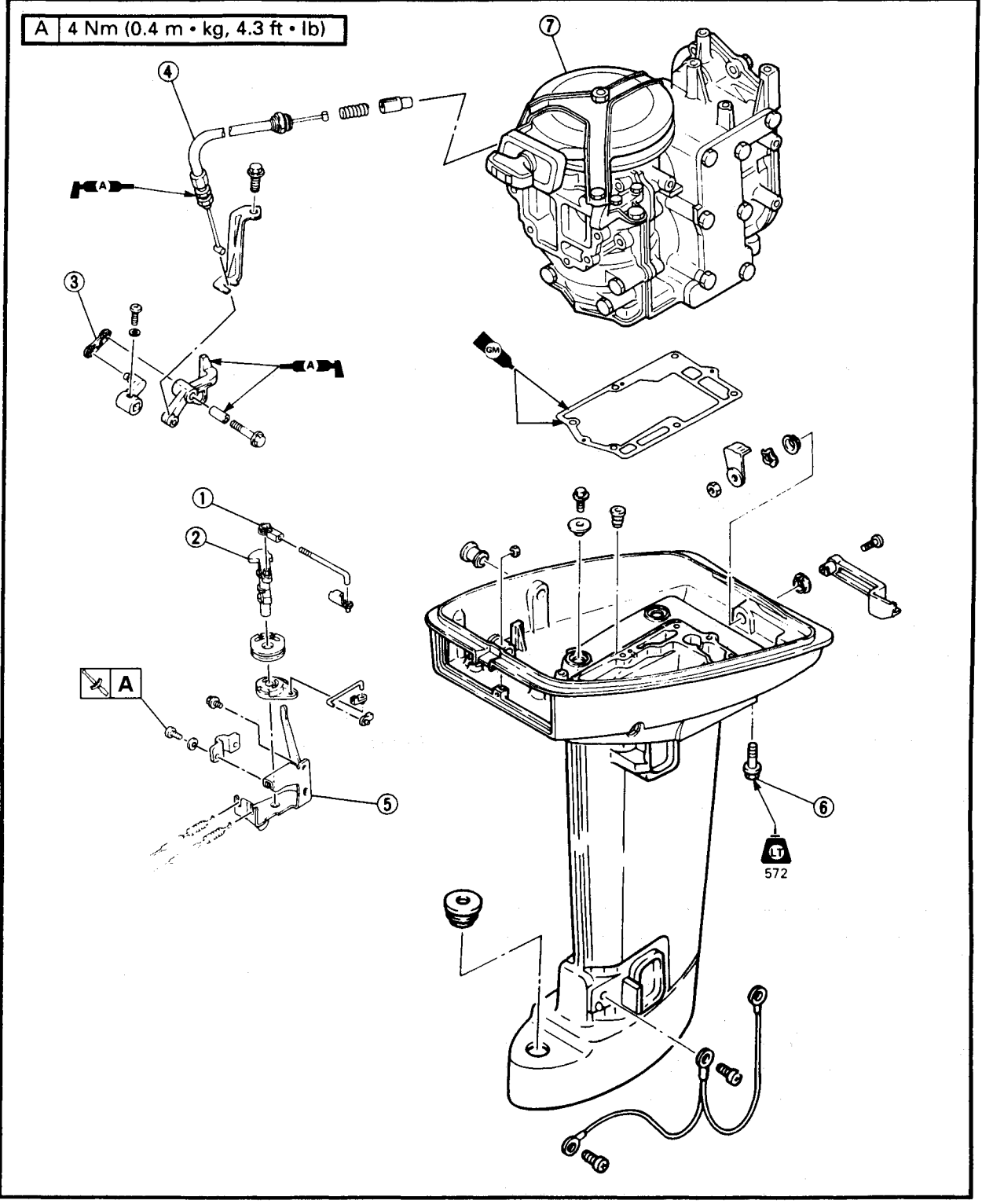



# POWER UNIT REMOVAL AND INSTALLATION

## NOTE ON REMOVAL AND REASSEMBLY

- Before servicing, clean the power unit.
- Remove any gasket adhered to the contacting surface.

Extent of removal: ① Power unit removal

Extent of removal	Order	Part name	Q'ty	Remarks
	1	Magneto control rod	1	Refer to "REMOVAL POINTS".
	2	Magneto control lever	1	
	3	Arm rod	1	
	4	Start-in-gear protection wire	1	
	5	Throttle wire stay	1	
	6	Bolt	6	
	7	Power unit	1	

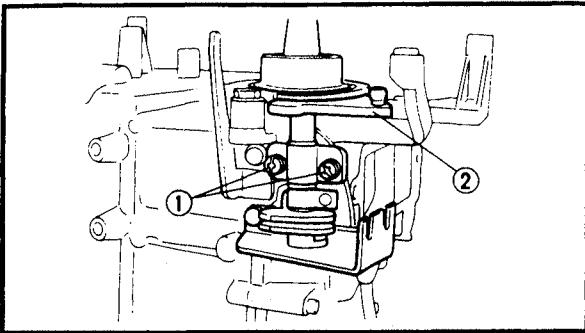

## REMOVAL POINTS

### Power unit

1. Remove:

- Magneto control rod
- Screw ①
- Magneto control lever ②

2. Remove:

- Arm rod ①

**A**: Except for Europe model

**B**: For Europe model

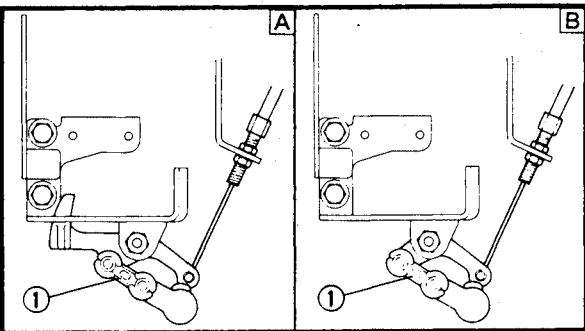

3. Remove:

- Start-in-gear protection wire

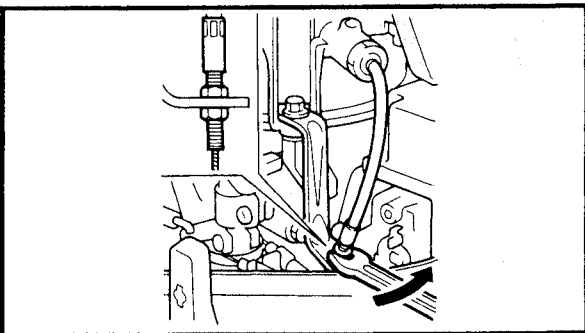

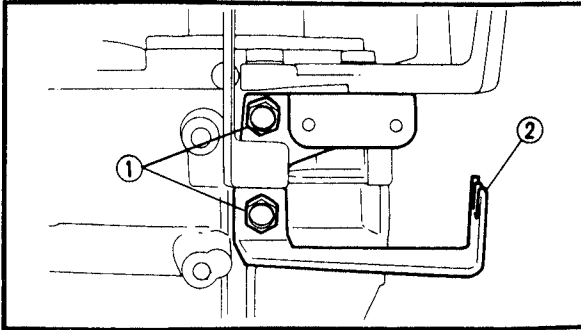

4. Remove:
- Bolt ①
  - Throttle wire stay ②

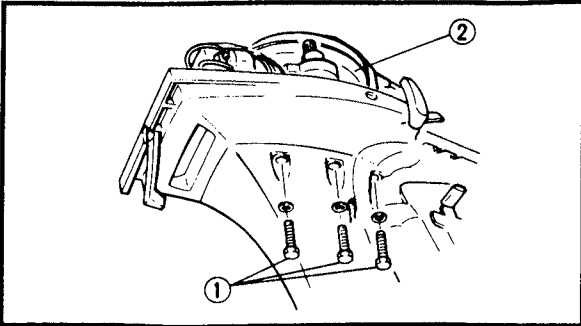

5. Remove:
- Bolt ①
  - Power unit ②
- By shaking the power unit lightly, lift it off.

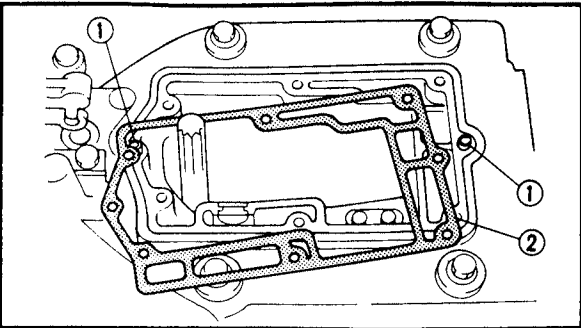

**ASSEMBLY AND INSTALLATION**

**Power unit**

1. Install:
- Dowel pin ①
  - Gasket ②

**NOTE:** \_\_\_\_\_

- Always use the new gasket.
- Clean the contacting surfaces of crankcase and bottom cowling.

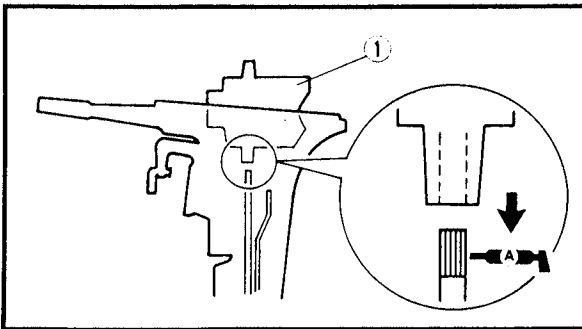

2. Install:
- Power unit ①

**NOTE:** \_\_\_\_\_

- Insert the drive shaft into the crankshaft. If the splines will not come in complete mesh, rotate the flywheel a little so that they are in mesh correctly.

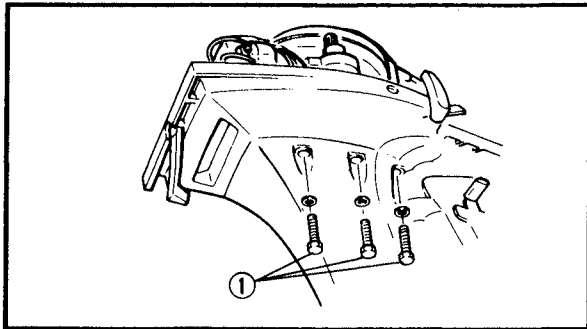

3. Install:
- Bolt ①

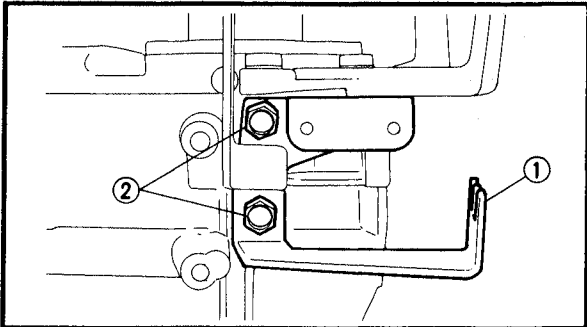

4. Install:
- Throttle wire stay ①
  - Bolt ②

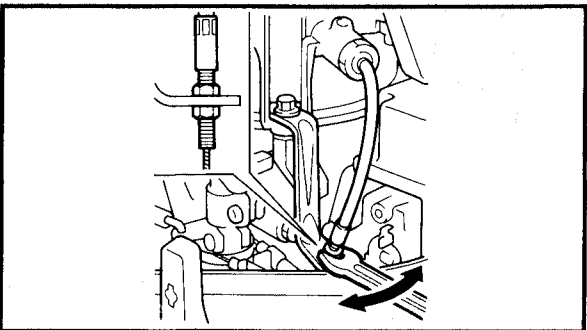

5. Install:
- Start-in-gear protection wire
6. Check:
- Start-in-gear protection operation  
Incollect → Adjust.  
Refer to page 3-13.

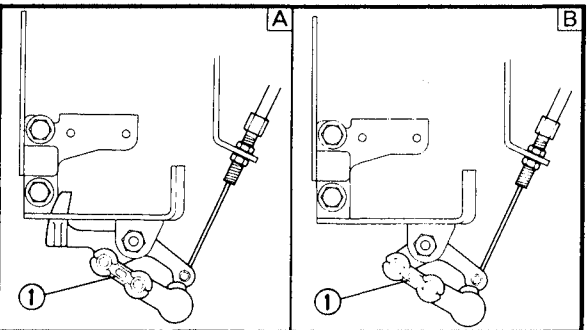

7. Install:
- Arm rod ①
- A: Except for Europe model  
B: For Europe model

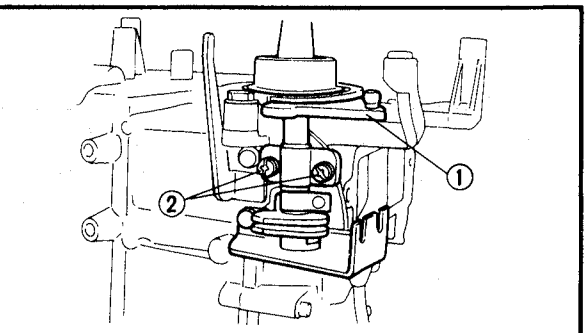

8. Install:
- Magneto control lever ①
  - Screw ②
  - Magneto control rod

**NOTE:** \_\_\_\_\_  
Face the arrow mark "↑" upward.  
\_\_\_\_\_



# CYLINDER, PISTON AND CRANKSHAFT

## CYLINDER, PISTON AND CRANKSHAFT PREPARATION FOR REMOVAL

- Remove the power unit.
- Remove the starter assembly.

A	45 Nm (4.5 m • kg, 32 ft • lb)
B	25 Nm (2.5 m • kg, 18 ft • lb)
C	1st: 4 Nm (0.4 m • kg, 2.9 ft • lb) 2nd: 8 Nm (0.8 m • kg, 5.8 ft • lb)
D	1st: 6 Nm (0.6 m • kg, 4.3 ft • lb) 2nd: 11 Nm (1.1 m • kg, 8.0 ft • lb)

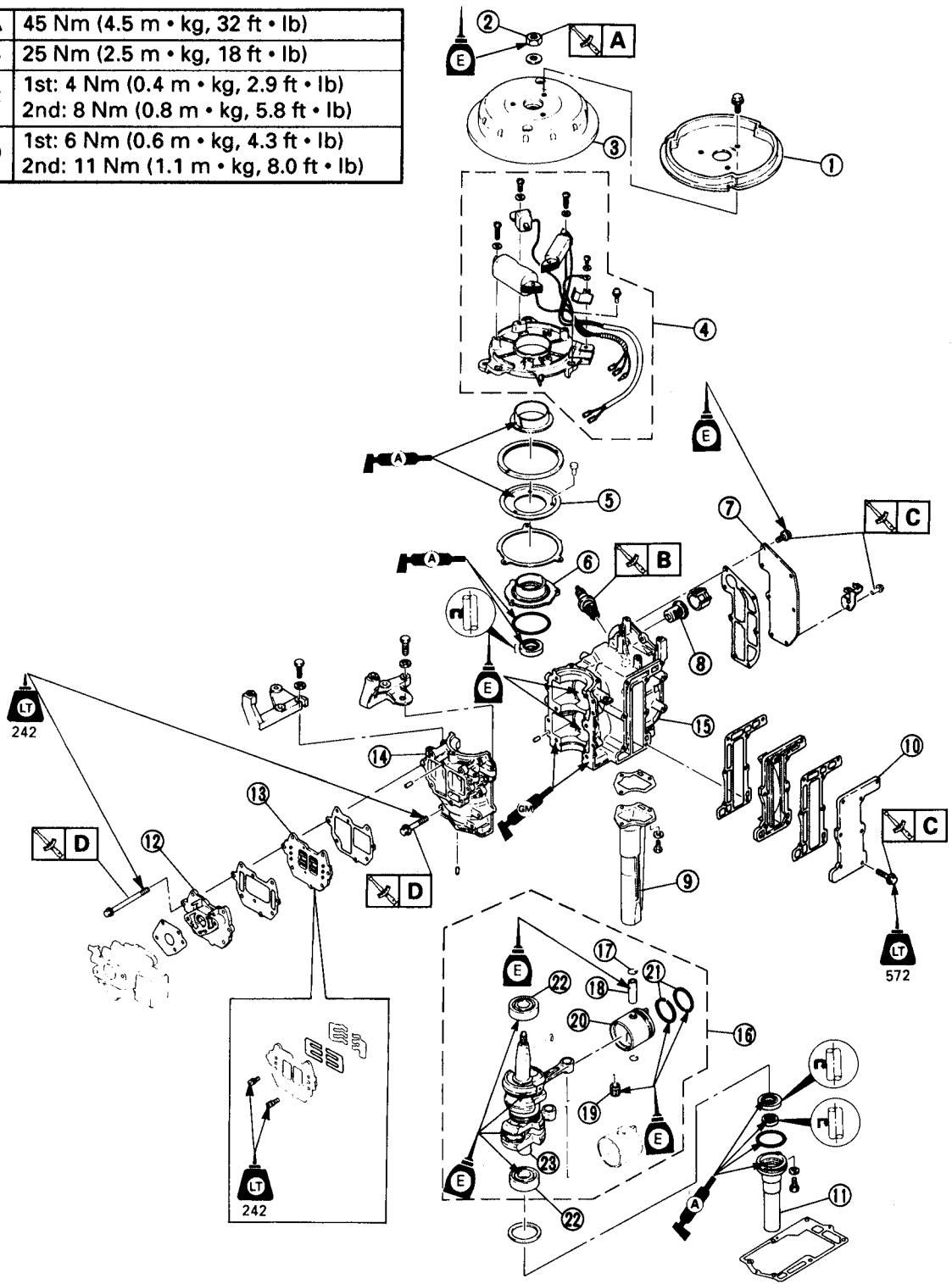





# CYLINDER, PISTON AND CRANKSHAFT

## NOTE ON REMOVAL AND REASSEMBLY

- Before servicing, clean the power unit.
- Note the piston and connecting rod for cylinder #1 and #2, their should be reset in the originally.
- Remove any gasket adhered to the contacting surface.
- Take care not to scratch the contacting surfaces when removing the cylinder and cylinder head.
- For reassembly, the removed parts should be cleaned with solvent, and apply the engine oil to the sliding surfaces.

Extent of removal:    ① Thermostat removal                      ② Reed valve removal  
                                  ③ Cylinder body disassembly                      ④ Crankshaft bearing removal

Extent of removal	Order	Part name	Q'ty	Remarks
	1	Starter pulley	1	Refer to "REMOVAL POINTS".
	2	Nut	1	
	3	Flywheel magneto	1	
	4	Stator assembly	1	
	5	Magneto base retainer	1	
	6	Oil seal housing	1	
	7	Cylinder head cover	1	
	8	Thermostat	1	
	9	Exhaust manifold	1	
	10	Exhaust cover	1	Refer to "REMOVAL POINTS".
	11	Oil seal housing	1	
	12	Intake manifold	1	
	13	Reed valve assembly	1	
	14	Crankcase	1	
	15	Cylinder body	1	Refer to "REMOVAL POINTS".
	16	Crankshaft and piston	1	
	17	Piston pin clip	4	
	18	Piston pin	3	
	19	Small end needle bearing	2	
	20	Piston	2	Refer to "REMOVAL POINTS".
	21	Piston ring	4	
	22	Crankshaft bearing	2	
	23	Crankshaft assembly	1	Refer to "REMOVAL POINTS".

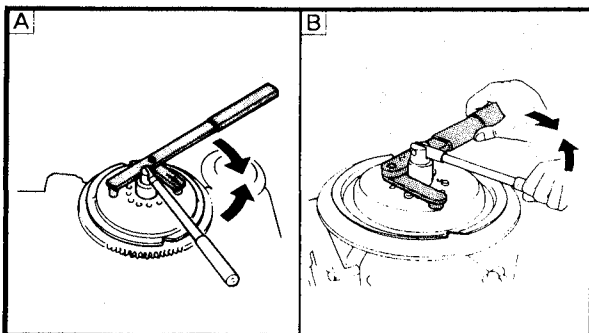

## REMOVAL POINTS

### Flywheel magneto

1. Remove:

- Nut ①

	<b>Flywheel holder:</b> <b>YB-6139/90890-06522</b>
--	---

Ⓐ For USA and CANADA

Ⓑ Except for USA and CANADA

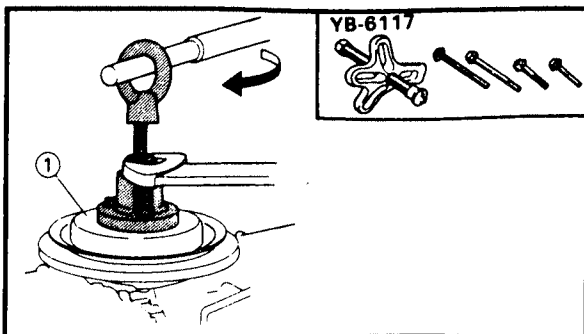

2. Remove:

- Flywheel magneto ①



**Flywheel puller:**  
YB-6117/90890-06521

**CAUTION:**

- Keep the nut side flush with the crankshaft end until the flywheel comes off the tapered portion of the crankshaft.
- To prevent damage to the engine or tools, screw in the flywheel magneto-puller set-bolts evenly and completely so that the puller plate is parallel to the flywheel.

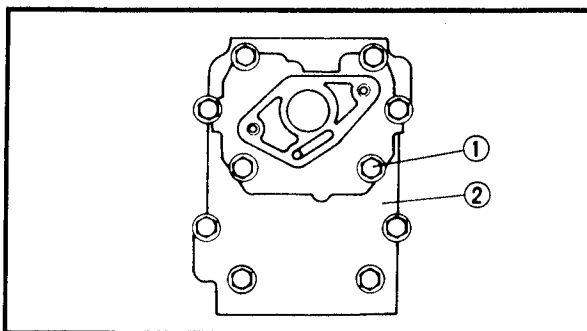
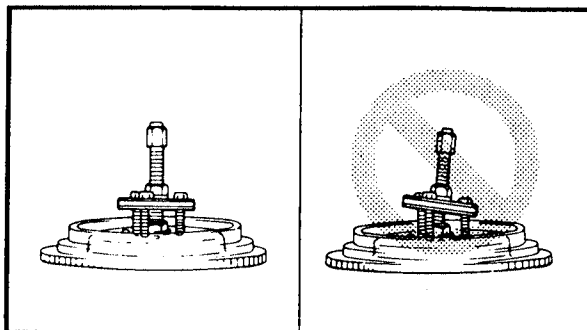
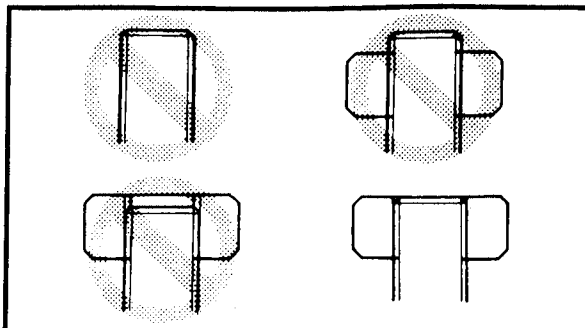

**Crankcase**

1. Remove:

- Bolt ①
- Crankcase ②

**NOTE:**

Insert a flat-head screwdriver between the tabs on both the right and left sides of the crankcase and cylinder and pry the two apart.

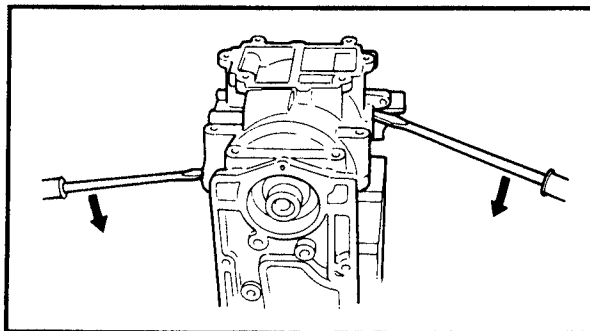

**CAUTION:**

Do not scratch the fitting surface of the crankcase.

# CYLINDER, PISTON AND CRANKSHAFT

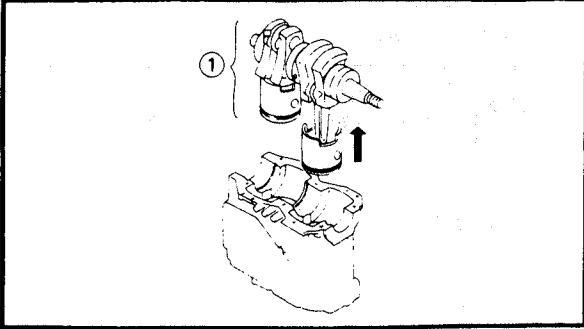

### Crankshaft and piston

1. Remove:
  - Crankshaft and piston ①

**NOTE:** \_\_\_\_\_  
Remove the crankshaft by lightly tapping it with a plastic hammer.

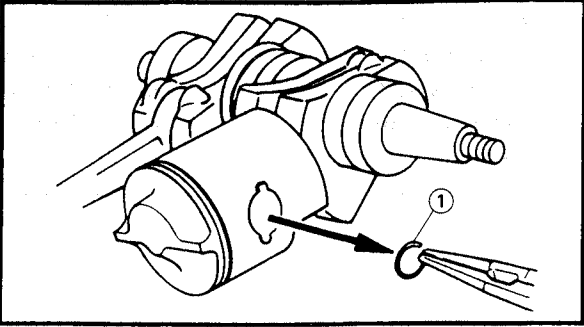

### Piston pin clip

1. Remove:
  - Piston pin clip ①

**CAUTION:** \_\_\_\_\_  
Do not damage piston pin hole edge.

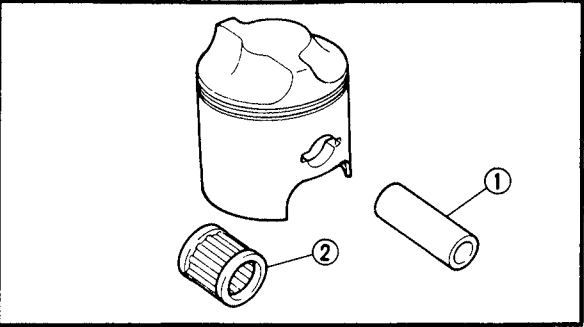

### Piston pin and small end bearing

1. Remove:
  - Piston pin clip ①
  - Small end needle bearing ②

**NOTE:** \_\_\_\_\_  
When the piston pins, pistons, and small end needle bearings are reused, they should be marked with No. 1 and 2 so that they are not confused.

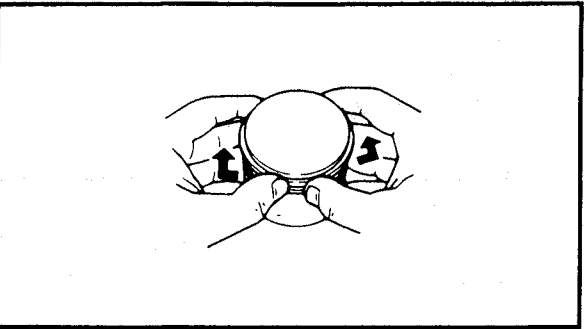

### Piston ring

1. Remove:
  - Piston ring

**CAUTION:** \_\_\_\_\_  
Remove the piston ring from the piston by opening the ring to the least possible width.

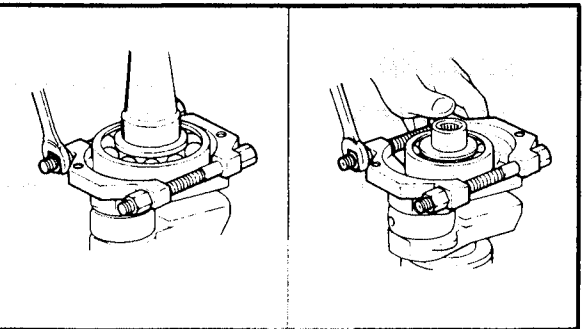

### Bearing

1. Remove:
  - Bearing

**NOTE:** \_\_\_\_\_  
Hold the bearing with the bearing separator, and force out the crankshaft with a press.



**Bearing separator:**  
YB-6219/90890-06534

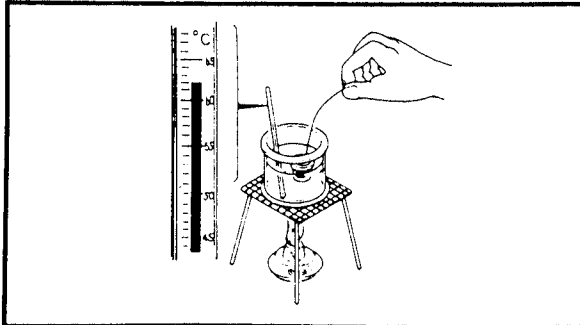
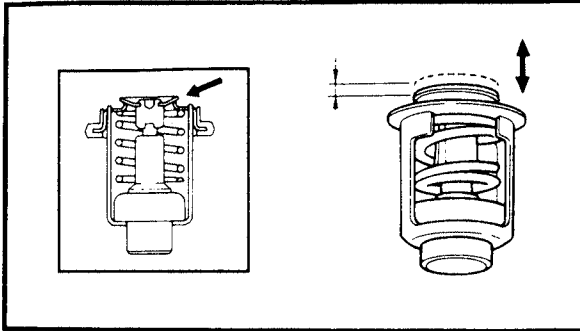

**INSPECTION AND REPAIR**

**Thermostat**

1. Inspect:
  - Thermostat  
Stick/Damage → Replace.
2. Measure:
  - Valve opening temperature
  - Valve lift  
Out of specification → Replace.

	Water temperature	Valve lift
	Below 48 ~ 52 °C (118 ~ 126 °F)	0 mm (0 in)
	Above 60 °C (140 °F)	Min. 3 mm (0.12 in)

**Measurement steps:**

- Suspend thermostat in a vessel.
- Place reliable thermometer in a water.
- Heat water slowly.
- Observe thermometer, while stirring water continually.

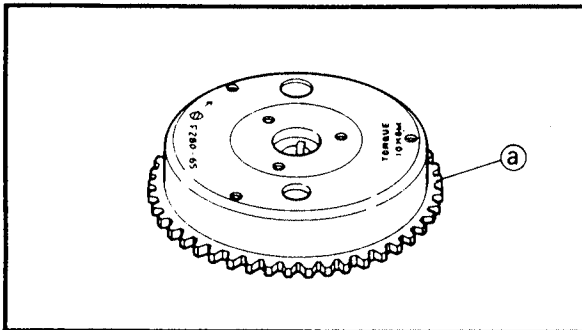

**Flywheel magneto**

6CM	6CEM	✓
8CM	8CEM	✓

1. Inspect:
  - Flywheel teeth **a**  
Wear/Damage → Replace.

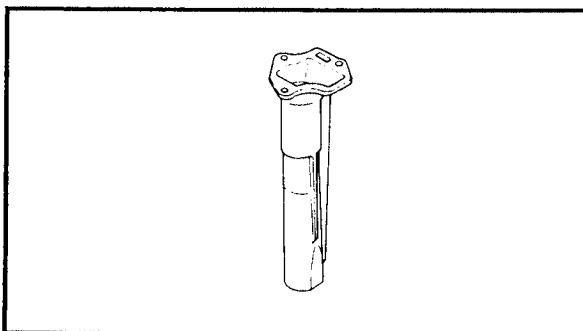

**Exhaust manifold**

1. Inspect:
  - Exhaust manifold  
Carbon deposits → Clean.  
Crack/Corrosion → Replace.

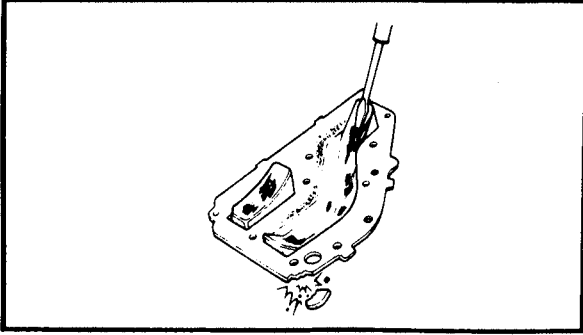

**Exhaust cover**

1. Inspect:
  - Exhaust cover  
Crack/Damage → Replace.  
Carbon deposit → Clean.

**CAUTION:**

Do not scratch the fitting surface of the cylinder and exhaust cover.

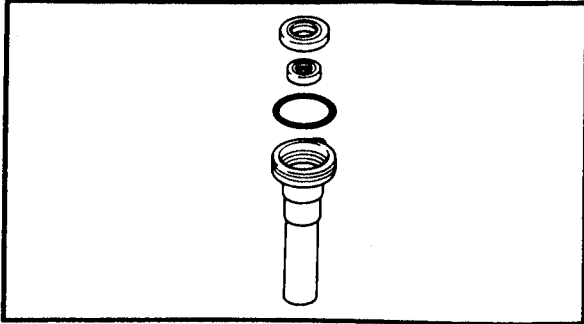

**Oil seal housing**

1. Inspect:
  - Oil seal housing  
Crack/Damage → Replace.

**Reed valve**

1. Inspect:
  - Reed valve  
Crack/Damage → Replace.

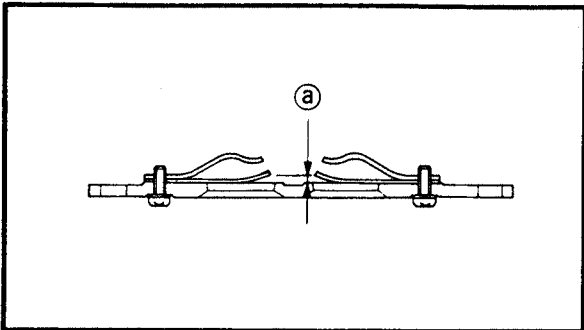

2. Measure:

- Valve bending (a)  
Out of specification → Replace.

	<b>Valve bending limit:</b> 0.2 mm (0.008 in)
---	--

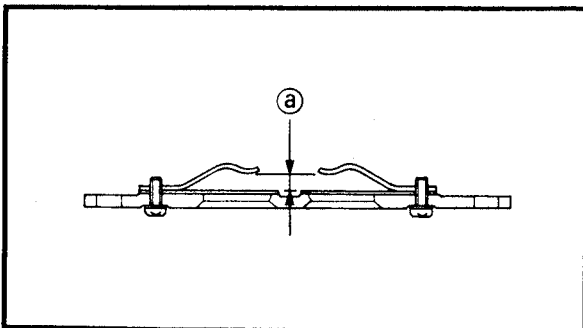

3. Measure:

- Valve Stopper height (a)  
Out of specification → Replace.

	<b>Valve stopper height:</b> 4.5 ± 0.2 mm (0.177 ± 0.008 in)
---	--

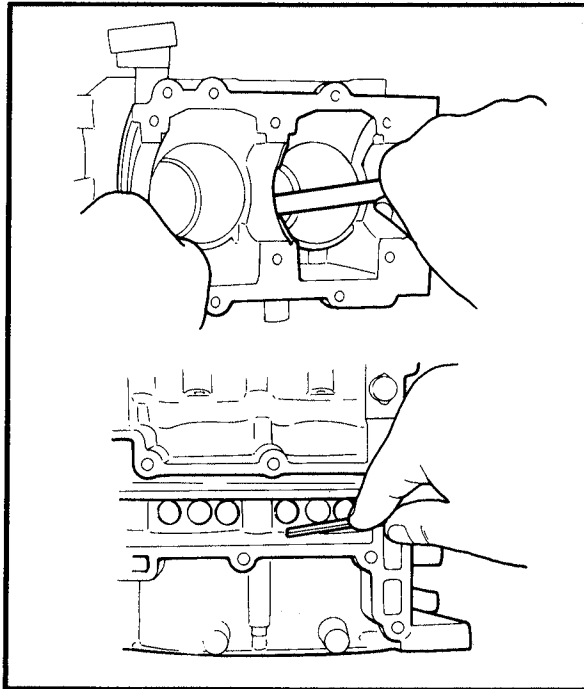

**Cylinder body**

1. Inspect:

- Water jacket  
Material deposit/Corrosion → Clean.
- Cylinder inner surface  
Score marks → Repair.  
Use #600 ~ 800 grit wet sandpaper.

**CAUTION:**

**Do not scratch the fitting surfaces of the cylinder and cylinder head.**

2. Inspect:

- Exhaust wall  
Crack/Damage → Replace.  
Carbon deposit → Clean.  
Use a round scraper.

**CAUTION:**

**Do not scratch the fitting surfaces of the cylinder and exhaust cover.**

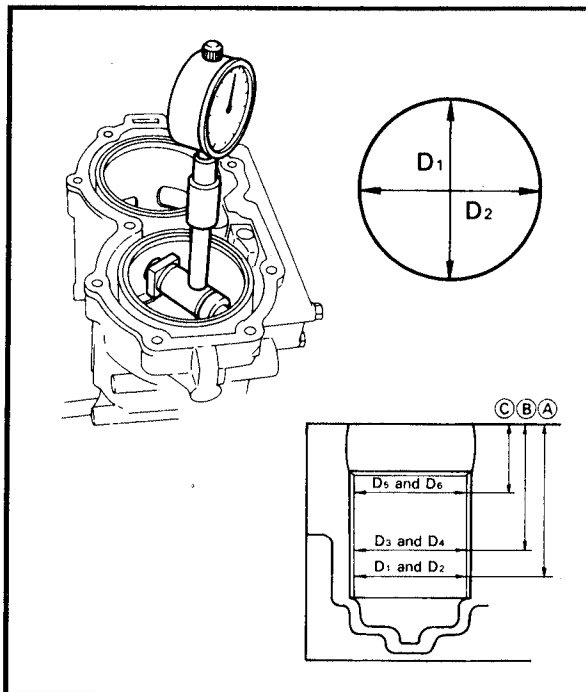

3. Measure:

- Cylinder bore "D"  
Use cylinder gauge.  
Out of specification → Rebore or replace.

**NOTE:**

Measure the cylinder bore "D" in parallel. Then, find the average of the measurement.

	Standard	Wear limit
Cylinder bore D:	50.00 ~ 50.03 mm (1.9685 ~ 1.9697 in)	50.1 mm (1.972 in)
Cylinder taper T:	-	0.08 mm (0.003 in)
<b>D = Maximum Dia. (D1 ~ D6)</b> <b>T = (Maximum D1 or D2) - (Minimum D5 or D6)</b>		

- Ⓐ 100 mm (3.94 in)
- Ⓑ 90 mm (3.70 in)
- Ⓒ 35 mm (1.38 in)

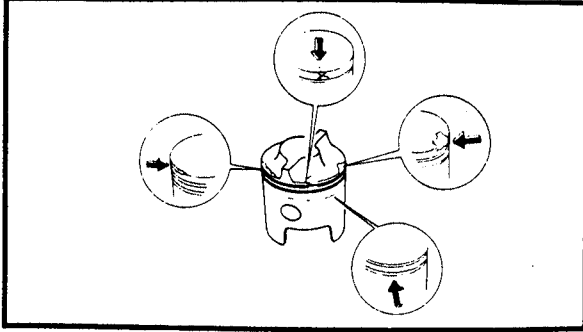

**Piston**

**1. Inspect:**

- Piston wall  
Wear/Scratch/Damage → Replace.

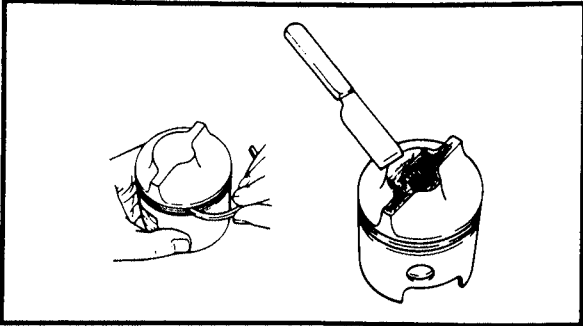

**2. Inspect:**

- Piston head
- Piston ring groove  
Carbon deposit → Clean.

**CAUTION:**

**Do not scratch the piston crown.**

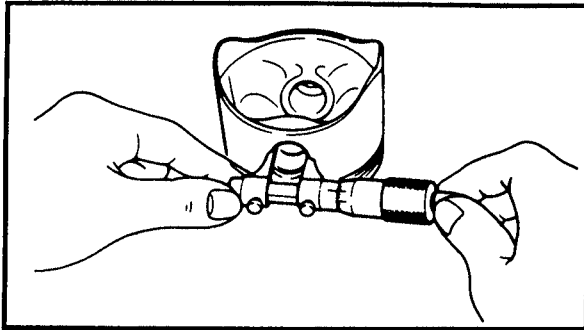

**3. Measure:**

- Piston pin boss inside diameter  
Use a micrometer.  
Out of specification → Replace.



**Piston pin boss inside diameter:  
12.004 ~ 12.015 mm  
(0.4726 ~ 0.4730 in)**

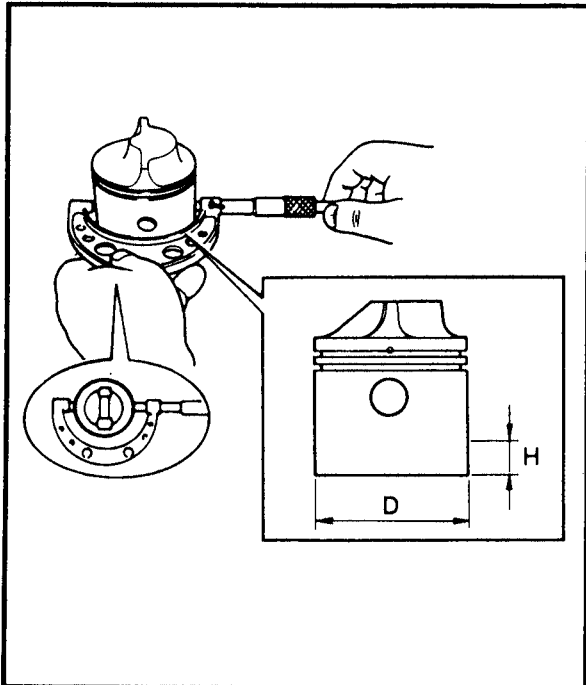

**4. Measure:**

- Piston diameter "D"  
Use a micrometer.  
Out of specification → Replace.

	Measuring point "H"	Piston diameter
Standard	10 mm (0.4 in)	49.955 ~ 49.980 mm (1.9667 ~ 1.9677 in)
Over 1* Size 2	-	50.25 mm (1.978 in)* 50.50 mm (1.988 in)

\*: Except for U.S.A.

**NOTE:**

"H" 10 mm (0.4 in) from the bottom edge.

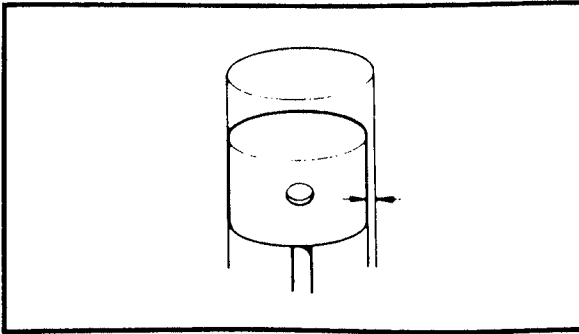

**Piston to cylinder clearance**

1. Calculate:

- Piston to clearance

Out of specification → Replace piston and piston ring and/or cylinder.

Piston clearance	=	Cylinder bore	-	Piston diameter
------------------	---	---------------	---	-----------------

	<b>Piston clearance:</b>
	<b>0.040 ~ 0.045 mm</b>
	<b>(0.0016 ~ 0.0018 in)</b>

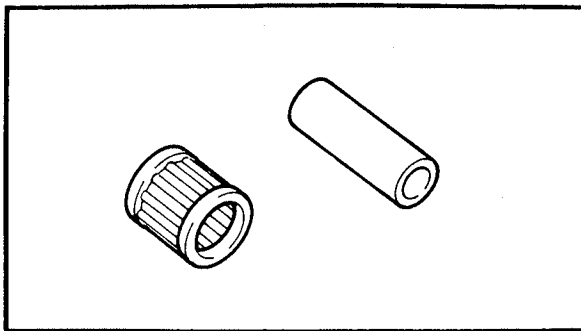

**Piston pin and small end bearing**

1. Inspect:

- Piston pin
- Small end bearing

Signs of heat discoloration →

Replace.

Scratch/Damage → Replace.

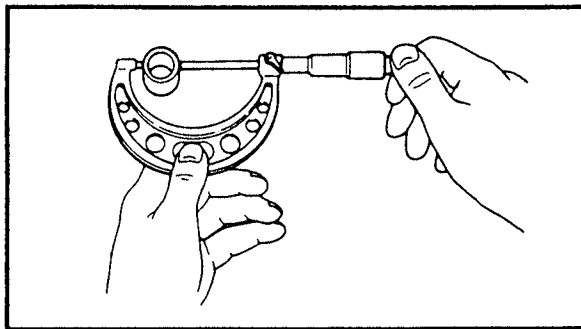

2. Measure:

- Piston pin diameter

Use a micrometer.

Out of specification → Replace.

	<b>Piston pin diameter:</b>
	<b>11.996 ~ 12.000 mm</b>
	<b>(0.4723 ~ 0.4724 in)</b>

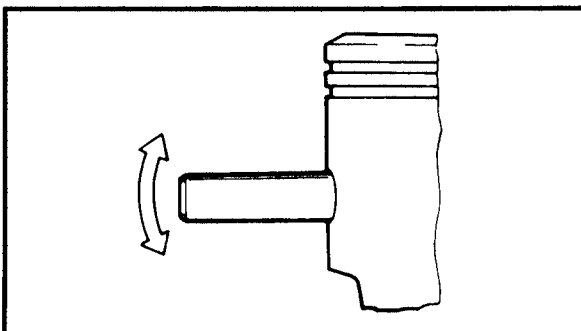

3. Check:

- Free play (when the piston pin is inserted in the piston.)

There should be no noticeable for the play.

Free play exists → Replace the pin and/or piston.



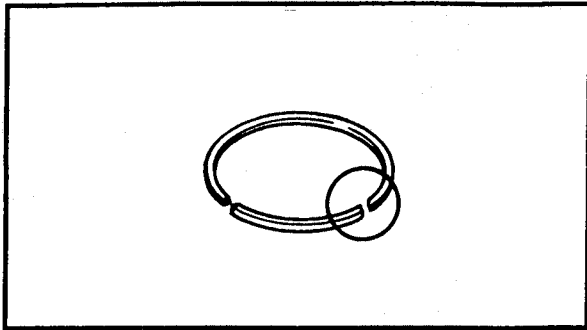

**Piston ring**

1. Inspect:

- Piston ring  
Breakage/Damage → Replace.

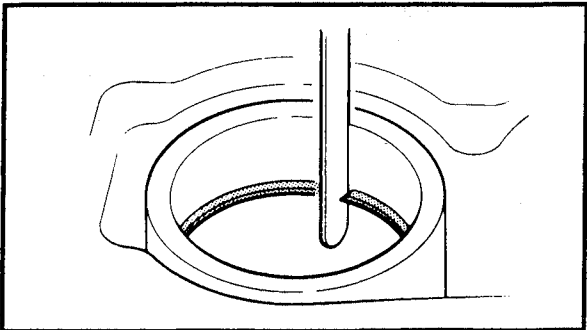

2. Measure:

- End gap  
Use a feeler gauge.  
Out of specification → Replace.

	End gap:	Measuring point "H"
Top	0.15 ~ 0.35 mm (0.006 ~ 0.014 in)	60 mm (2.36 in)
2nd	0.15 ~ 0.35 mm (0.006 ~ 0.014 in)	

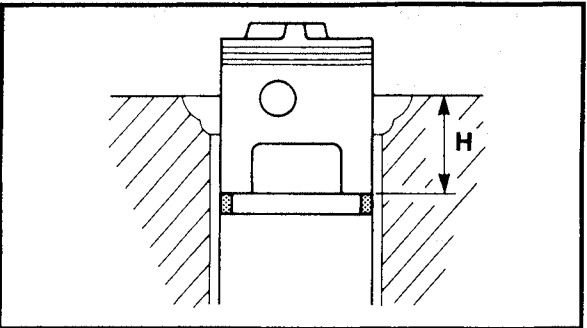

**NOTE:**

- Install the piston ring into the cylinder.  
Push the ring with the piston crown.
- "H" 60 mm (2.36 in) from the contact face.

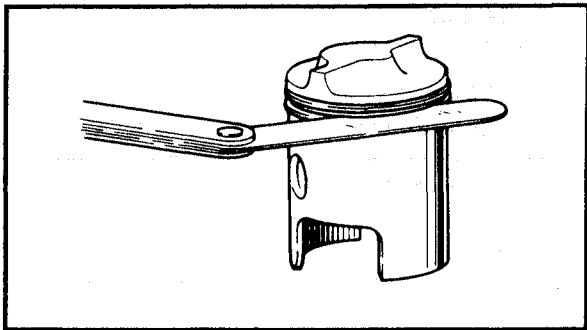

3. Measure:

- Side clearance  
Use a feeler gauge.  
Out of specification → Replace piston and/or ring.

	Side clearance:
	Top: 0.02 ~ 0.06 mm (0.0008 ~ 0.0024 in)
	2nd: 0.03 ~ 0.07 mm (0.0012 ~ 0.0028 in)

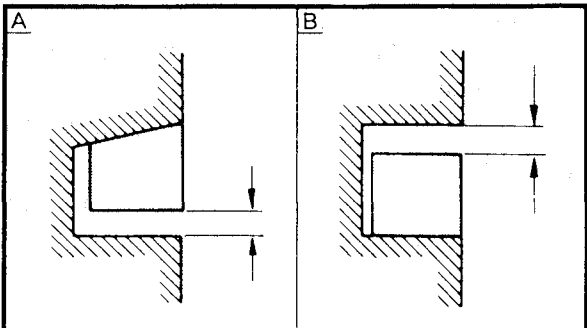

- A** Top
- B** 2nd

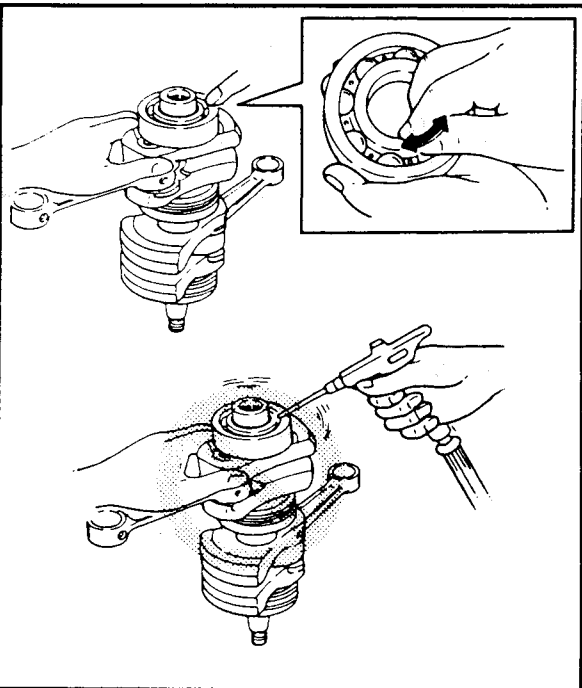
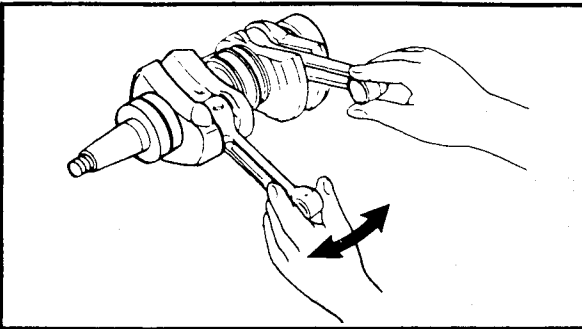
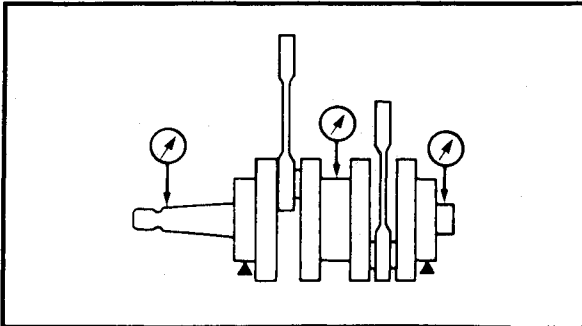
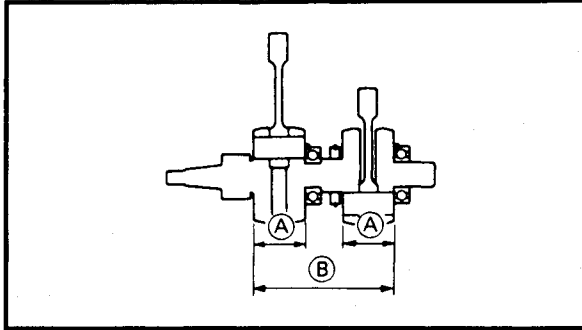

**Crankshaft**

1. Measure:

- Crank width (A)
- Crank width (B)

Out of specification → Replace.

	<b>Crank width (A):</b> 39.90 ~ 39.95 mm (1.571 ~ 1.573 in)
	<b>Crank width (B):</b> 101.7 ~ 102.0 mm (4.004 ~ 4.016 in)

2. Measure:

- Runout
- Use a V-blocks and dial gauge.  
Out of specification → Replace.

	<b>Runout limit:</b> 0.03 mm (0.0012 in)
--	---

3. Measure:

- Axial play
- Out of specification → Replace.

	<b>Axial play limit:</b> 2.0 mm (0.08 in)
--	--

4. Inspect:

- Crankshaft bearing
- Abnormal noise/Turn roughly/  
Damage → Replace.

**CAUTION:** \_\_\_\_\_  
**Blow-dry the bearing without spinning it marking scratches on the bearing balls.**  
 \_\_\_\_\_

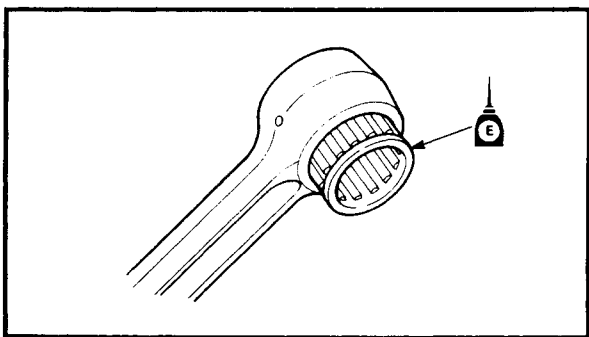
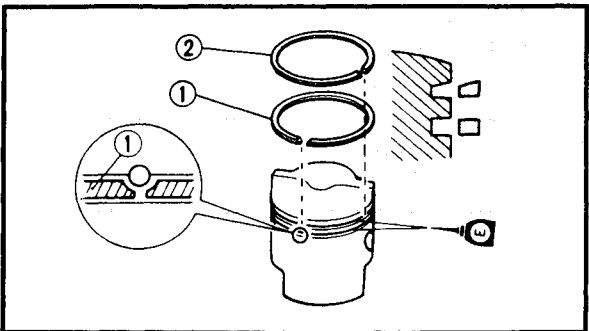
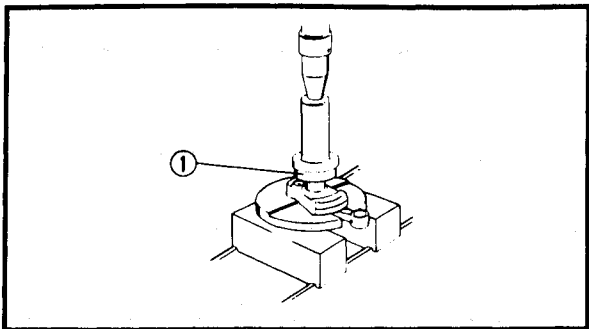
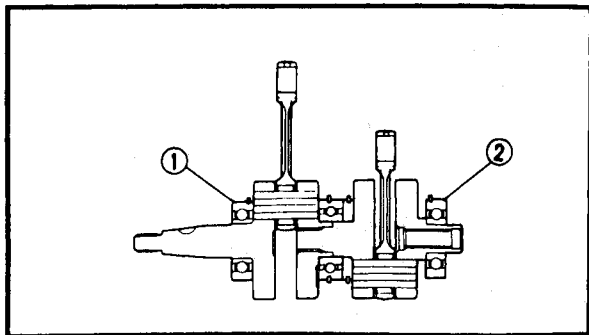

**ASSEMBLY AND INSTALLATION**

**Bearing**

1. Install:

- Bearing ①
- Bearing ②

**NOTE:** \_\_\_\_\_

Place the plate under the connecting rod big end, slip the bearing over the crankshaft, and press-fit the bearing.

**CAUTION:** \_\_\_\_\_

- After placing the plate under the big end, make sure the connecting rod is held in a vertical position.
- When press-fitting the bearing, be sure to force the inner race. Do not force the outer race.

**Piston and piston ring**

1. Install:

- Piston ring (2nd) ①
- Piston ring (top) ②

**NOTE:** \_\_\_\_\_

- Piston rings should be replaced as a set.
- Take care not to scratch the piston or break piston rings.
- Align the each ring end gap with their locating pins.
- After fitting the rings, check that they move smoothly.
- Apply 2-stroke outboard motor oil to the pistons and rings.

**Crankshaft and piston**

1. Install:

- Small end needle bearing

**NOTE:** \_\_\_\_\_

Apply 2-stroke outboard motor oil to the bearing.

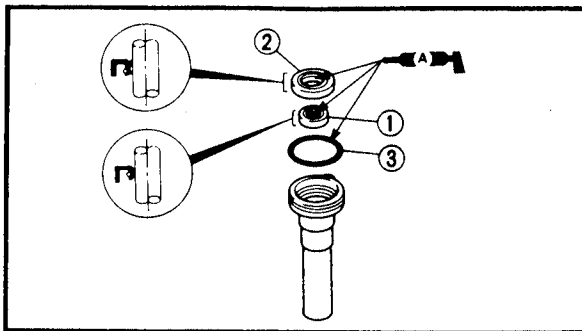
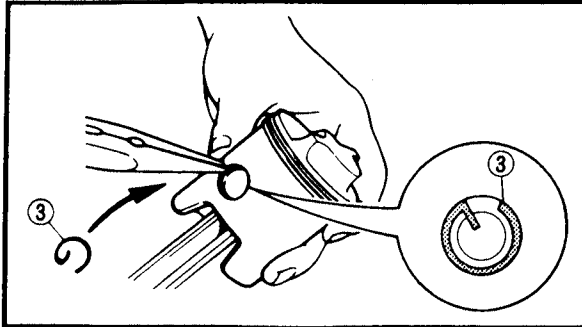
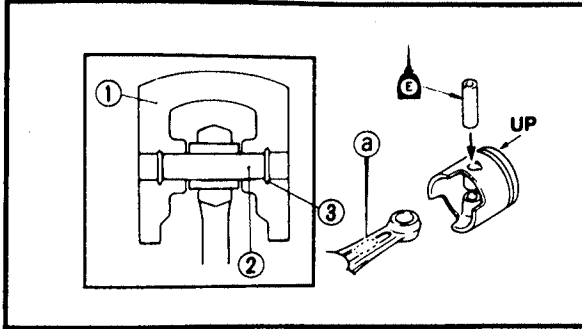

**2. Install:**

- Piston ①
- Piston pin ②
- Piston pin clip ③

**NOTE:**

- Mold mark ② faces in the same direction as the "UP" mark on the piston.
- When no piston is replaced, be sure to re-install the pistons in their original cylinder.
- Always use the new circlip.
- Apply 2-stroke outboard motor oil to the piston pin.

**Oil seal housing**

**1. Install:**

- Oil seal ①
- Oil seal ②
- O-ring ③

**NOTE:**

- Apply water resistant grease to the oil seal lip and the O-ring.
- When press-fitting the oil seal, be sure that it faces in the correct direction.
- Always use the new O-ring.

**Reed valve assembly**

**1. Install:**

- Reed valve ①
- Valve stopper ②
- Screw ③

**NOTE:**

Apply blue LOCTITE® No. 242 to the screw.

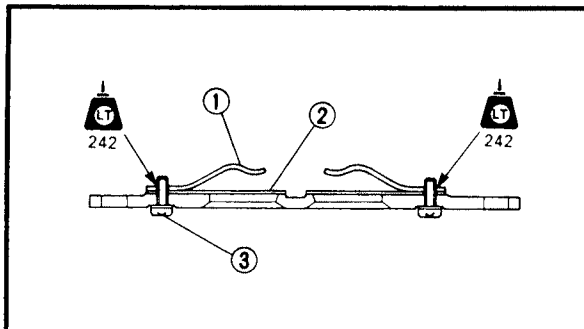

**Screw:**  
1 Nm (0.1 m • kg, 0.7 ft • lb)

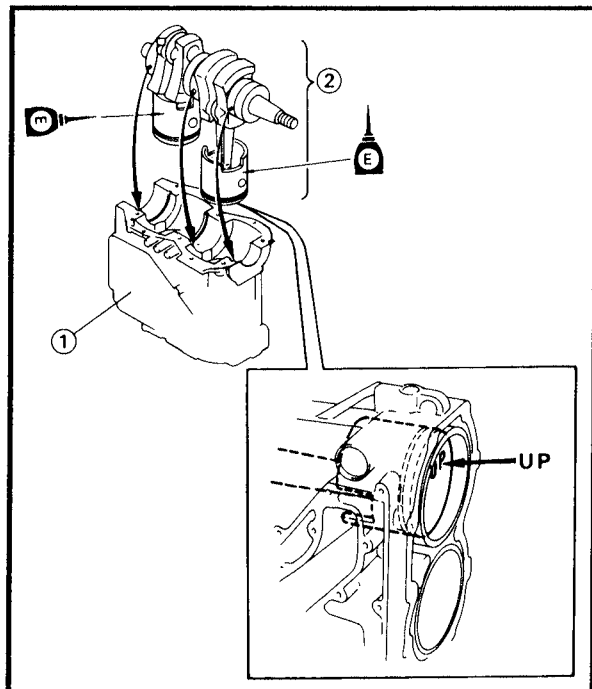

**Cylinder body and crankcase**

1. Install:

- Cylinder body ①
- Crankshaft and piston ②

**NOTE:**

- Apply 2-stroke outboard motor oil to the cylinder wall, piston and its rings.
- Align the piston ring end gaps with the respective locating pins.
- Fit the bearing and the labyrinth seal locating pins in the cylinder body.

2. Apply:

- Gasket maker  
Onto the connecting surfaces of the crankcase and cylinder body.

**NOTE:**

- Clean the connecting surfaces of the crankcase and cylinder body before applying the Gasket Maker.
- Gasket maker should be so applied that it does not overflow the contacting surface.

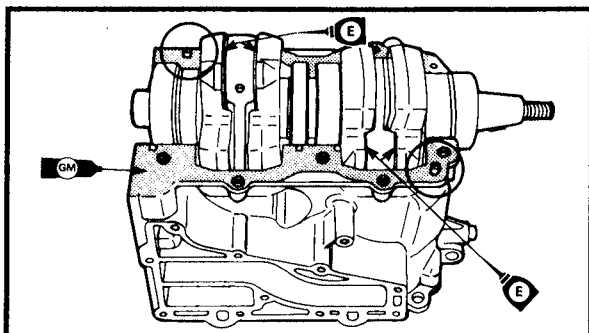

3. Install:

- Dowel pin
- Crankcase ①
- Reed valve assembly
- Intake manifold ②
- Bolt ③

**NOTE:**

- Apply blue LOCTITE® No. 242 to the bolts.
- Tighten the bolts in sequence and in two steps of torque.

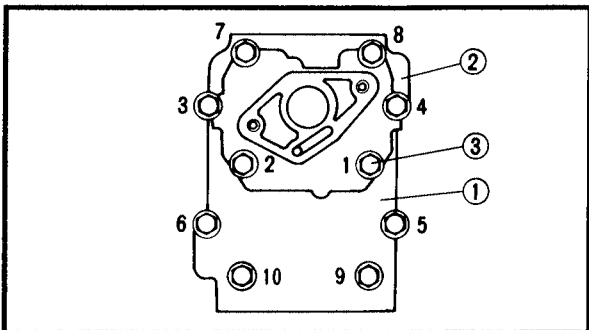

	<b>Bolt:</b>
	<b>1st:</b> 6 Nm (0.6 m · kg, 4.3 ft · lb)
	<b>2nd:</b> 11 Nm (1.1 m · kg, 8.0 ft · lb)

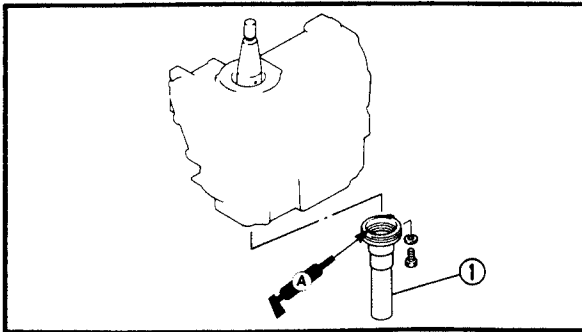

**4. Install:**

- Oil seal housing ①

**NOTE:**

Apply water resistant grease to connecting surface of oil seal housing.

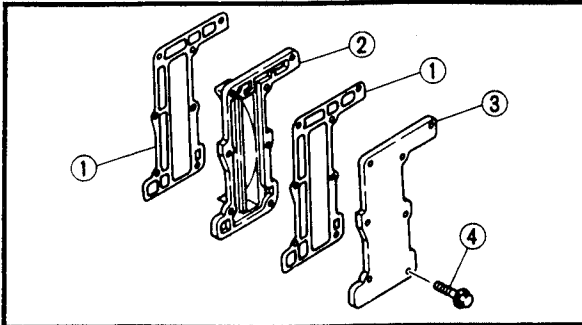

**Exhaust cover**

**1. Install:**

- Gasket ①
- Exhaust inner cover ②
- Exhaust outer cover ③
- Bolt ④

**NOTE:**

- Apply LOCTITE® No. 572 to the bolts.
- Tighten the bolts in sequence and in two steps of torque.

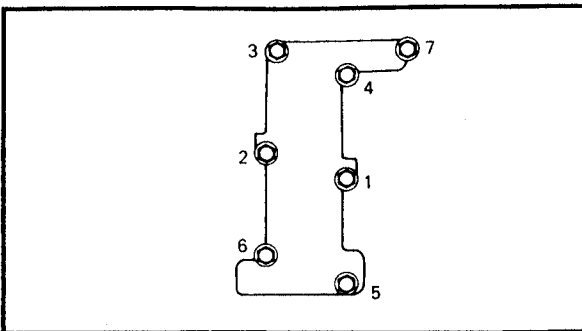

**Bolt:**

**1st:**

**4 Nm (0.4 m · kg, 2.9 ft · lb)**

**2nd:**

**8 Nm (0.8 m · kg, 5.8 ft · lb)**

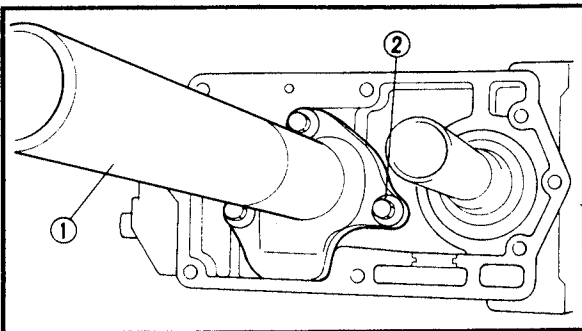

**Exhaust manifold**

**1. Install:**

- Exhaust manifold ①
- Bolt ②

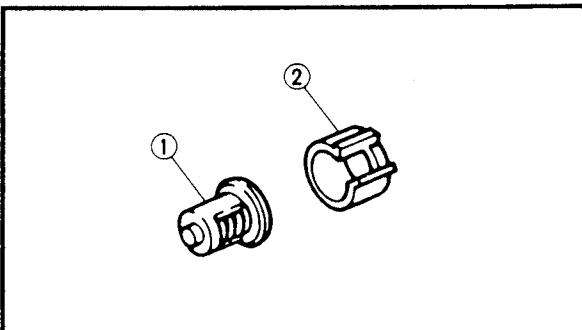

**Cylinder head cover**

**1. Install:**

- Thermostat ①
- Collar ②

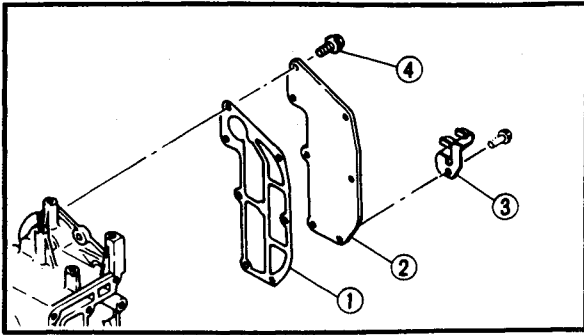

2. Install:

- Gasket ①
- Cylinder head cover ②
- Clamp ③
- Bolt ④

NOTE:

- Apply 2-stroke outboard motor oil to the bolts.
- Tighten the bolts in sequence and in two steps of torque.

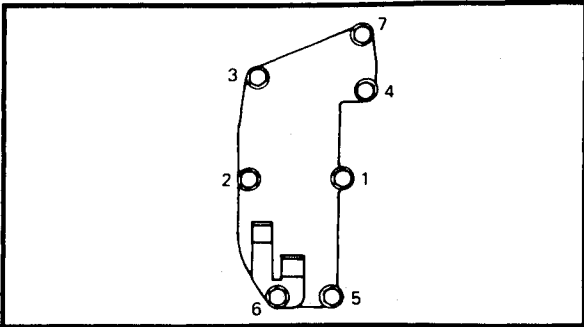

**Bolt (cylinder head cover):**

1st:

4 Nm (0.4 m · kg, 2.9 ft · lb)

2nd:

8 Nm (0.8 m · kg, 5.8 ft · lb)

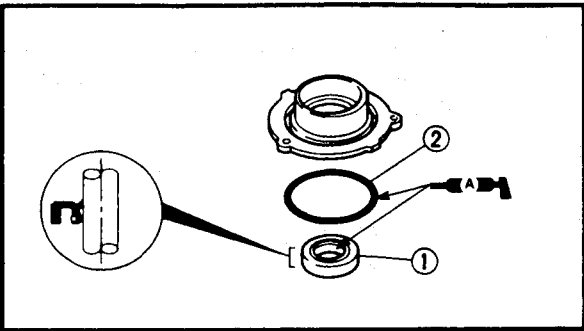

**Oil seal housing**

1. Install:

- Oil seal ①
- O-ring ②

NOTE:

- Apply water resistant grease to the oil seal lip and the O-ring.

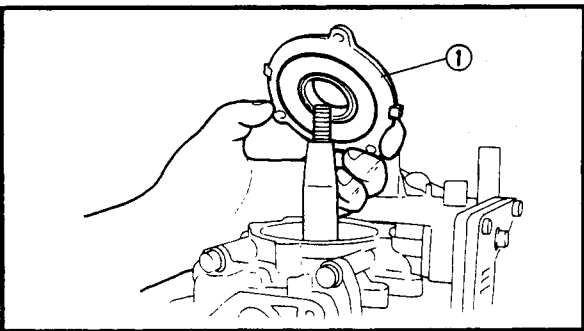

2. Install:

- Oil seal housing ①

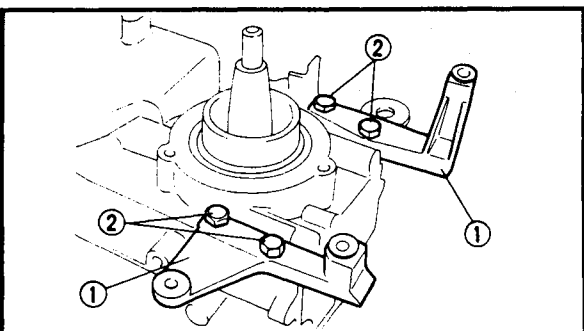

**Flywheel magneto**

1. Install:

- Starter stay ①
- Bolt ②

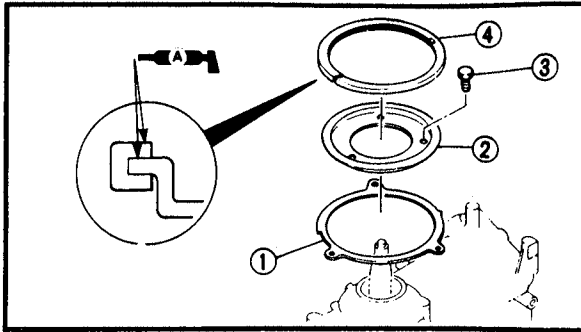

2. Install:
- Friction plate ①
  - Retainer ②
  - Bolt ③
  - Retainer ring ④

**NOTE:** \_\_\_\_\_  
 Apply water resistant grease to the retainer ring.

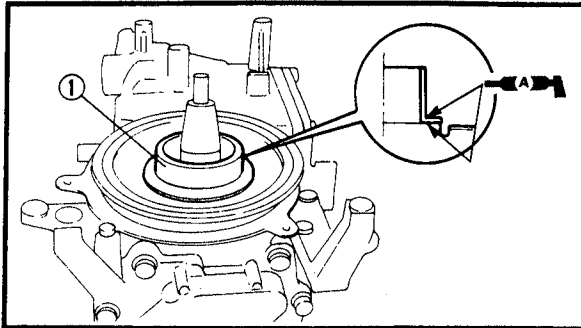

3. Install:
- Bushing ①

**NOTE:** \_\_\_\_\_  
 Apply water resistant grease to both inner and outer surfaces of the bushing.

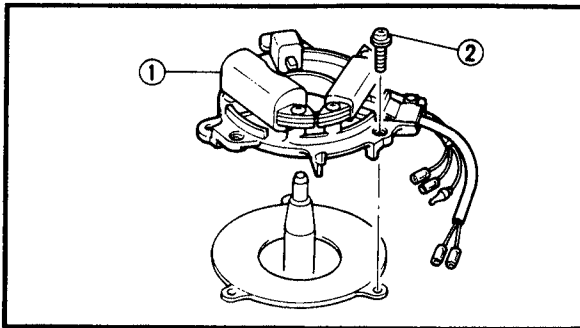

4. Install:
- Stator assembly ①
  - Screw ②
5. Check:
- Stator assembly
- Stiff → Repair.

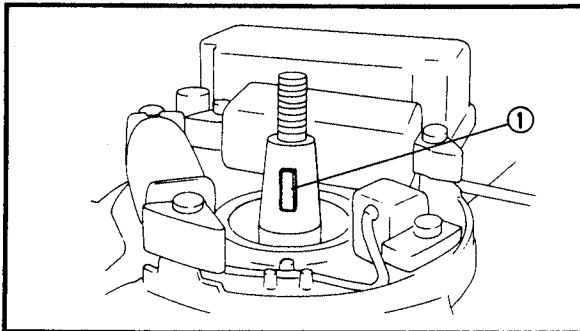

6. Install:
- Woodruff key ①

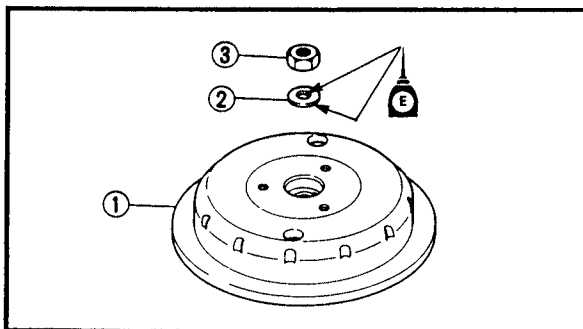



7. Install:
- Flywheel magneto ①
  - Washer ②
  - Nut ③

**NOTE:** \_\_\_\_\_  
 ● Make sure the woodruff key is properly seated in the keyway of the crankshaft.  
 ● Apply 2-stroke outboard motor oil to both surfaces of the washer.

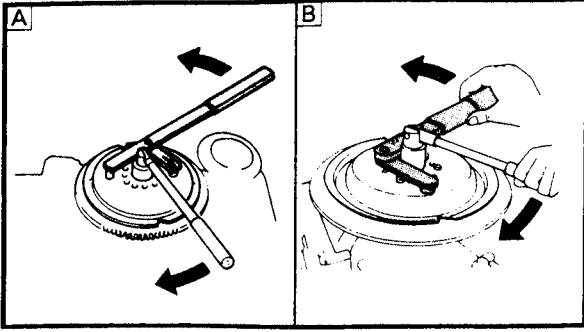

# CYLINDER, PISTON AND CRANKSHAFT



 **Flywheel holder:**  
**YB-6139/90890-06522**

- A** For USA and CANADA
- B** Except for USA and CANADA

 **Nut:**  
**45 Nm (4.5 m • kg, 32 ft • lb)**

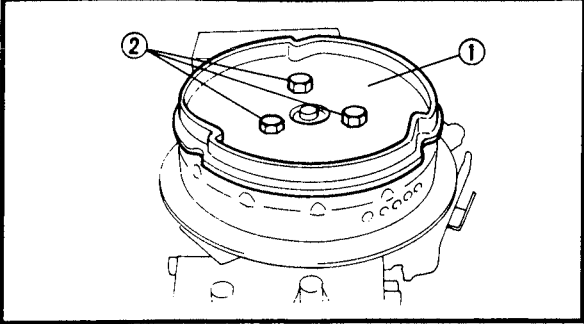

- 8. Install:**
- Starter pulley ①
  - Bolt ②



**RECOIL STARTER  
PREPARATION FOR REMOVAL**

- Removal the top cowling.

**⚠ WARNING**

**Wear a proper safety goggle and gloves for protect your eyes and hands. Because; the spiral jumps out and may injure a person.**

A	5 Nm (0.5 m • kg, 3.6 ft • lb)
B	4 Nm (0.4 m • kg, 2.9 ft • lb)

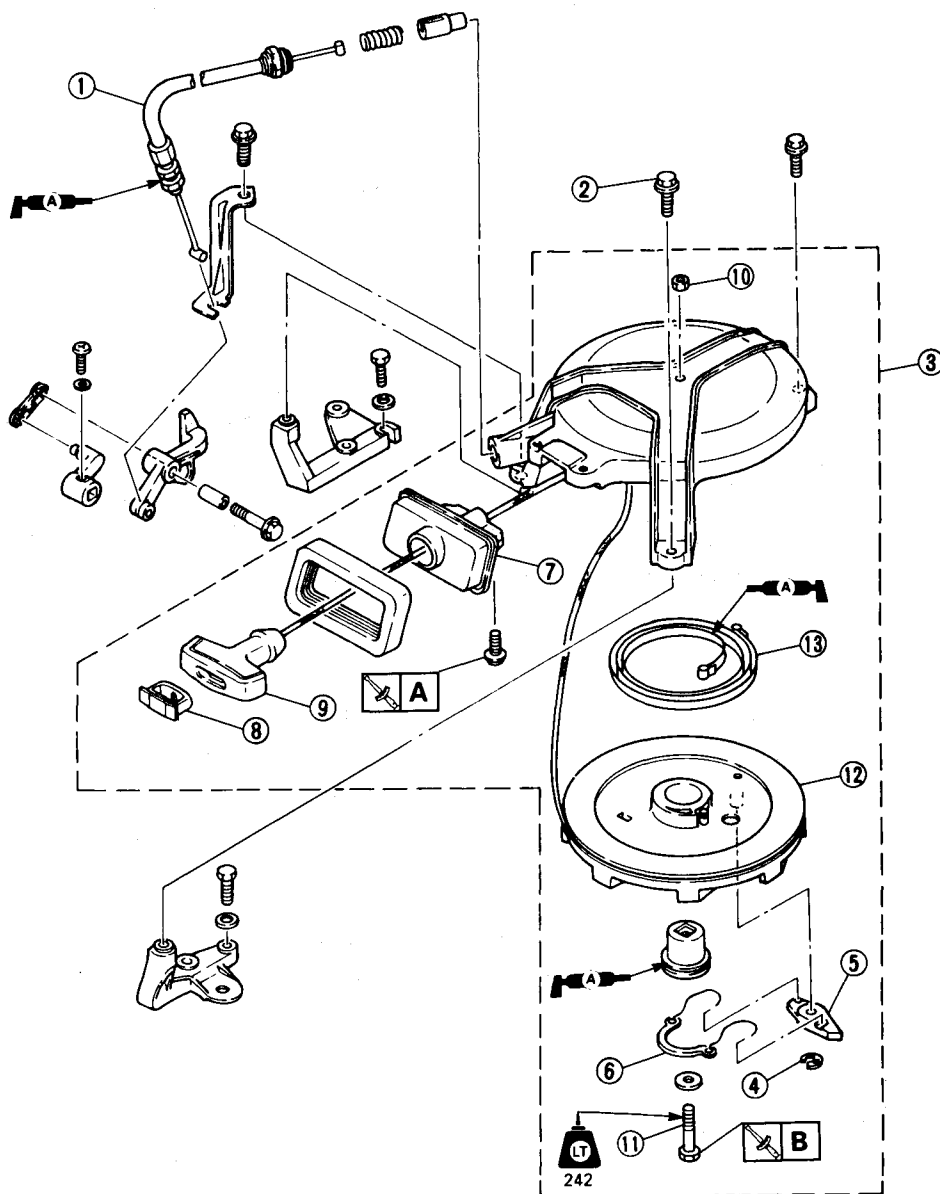



Extent of removal: ① Recoil starter removal      ② Recoil starter disassembly

Extent of removal	Order	Part name	Q'ty	Remarks
	1	Start-in-gear protection wire	1	Disconnect the wire at starter side.
	2	Bolt	3	
	3	Recoil starter assembly	1	
	4	Circlip	1	
	5	Drive pawl	1	
	6	Drive pawl spring	1	
	7	Rope guide	1	
	8	Cover	1	
	9	Starter handle	1	
	10	Nut	1	
	11	Bolt	1	} Refer to "REMOVAL POINTS".
	12	Sheave drum	1	
	13	Spiral spring	1	

**REMOVAL POINTS**

**Sheave drum**

1. Turn:

- Sheave drum ①  
Turn the sheave drum clockwise until the spiral spring is free.

**NOTE:**

- Turn the sheave drum so that the cutaway on the outer surface of the sheave drum faces toward the starter handle.
- Pass the starter rope through the cut.

2. Remove:

- Nut
- Bolt
- Bushing
- Sheave drum ①

**NOTE:**

Insert a slotted-head screwdriver into the hole in the sheave drum, and remove the spiral spring from the sheave drum by pushing the spring.

**Spiral spring**

1. Remove:

- Spiral spring ①

**NOTE:**

Be careful so that the spiral spring does not pop out when removing it. Remove it by allowing it out one turn of the winding each time.

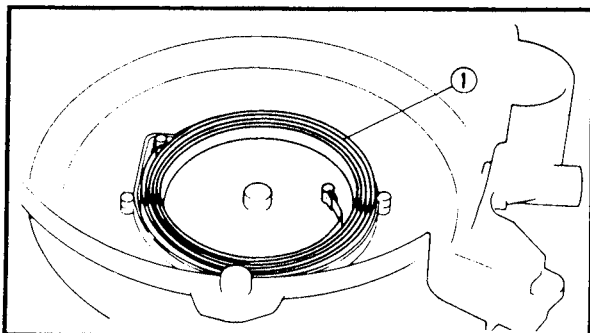
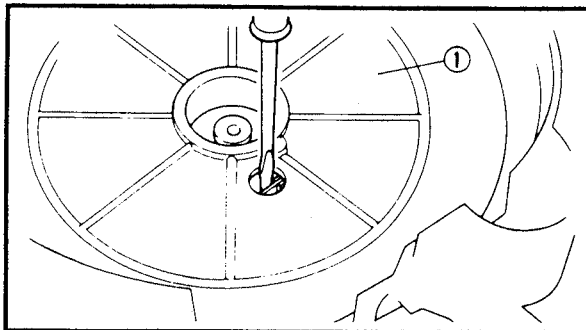
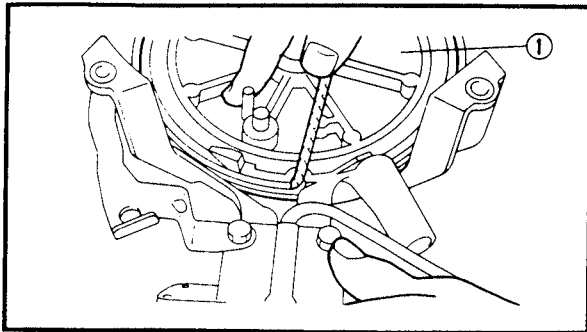

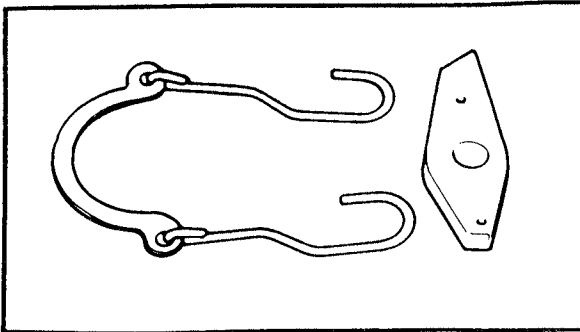

**INSPECTION**

**Drive pawl and spring**

1. Inspect:
  - Drive pawl  
Crack/Wear/Damage → Replace.
  - Drive pawl spring  
Broken/Bent/Damage → Replace.

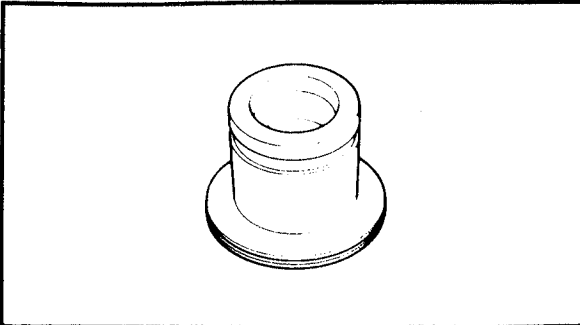

**Bushing**

1. Inspect:
  - Bushing  
Crack/Damage → Replace.

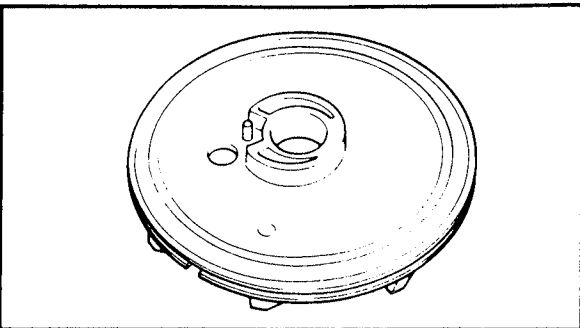

**Sheave drum**

1. Inspect:
  - Sheave drum  
Crack/Damage → Replace.

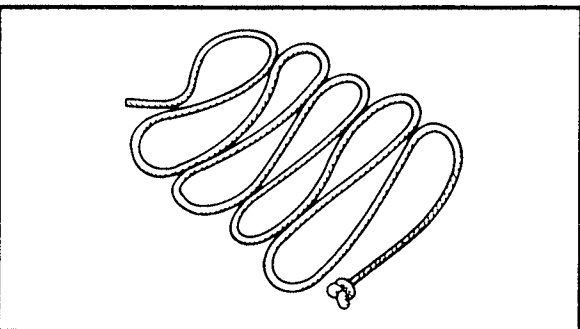

**Starter rope**

1. Inspect:
  - Starter rope  
Broken/Wear/Damage → Replace.

**NOTE:** \_\_\_\_\_  
 When replacing the rope, cut it to the specified length and burn the rope end so that it will not fray.

	<b>Starter rope length:</b> 1,850 mm (72.8 in)
--	---

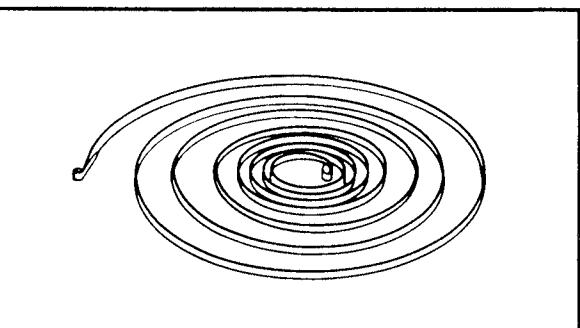

**Spiral spring**

1. Inspect:
  - Spiral spring  
Broken/Bent/Damage → Replace.

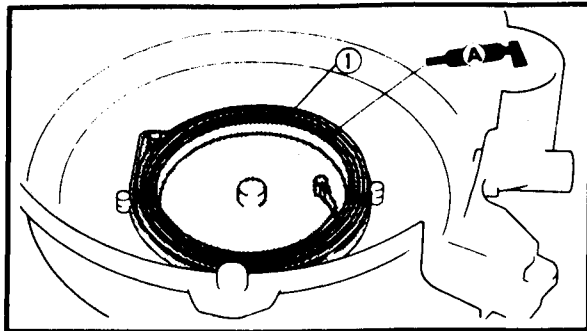

**ASSEMBLY AND INSTALLATION**

**Recoil starter**

**1. Install:**

- Spiral spring ①

**NOTE:**

- After installing the new spiral spring, cut the wire holding the spring.
- When reusing the spiral spring, set the leading end first in the case and then fit one turn each time.

**⚠ WARNING**

The spiral spring may jump out so use special care.

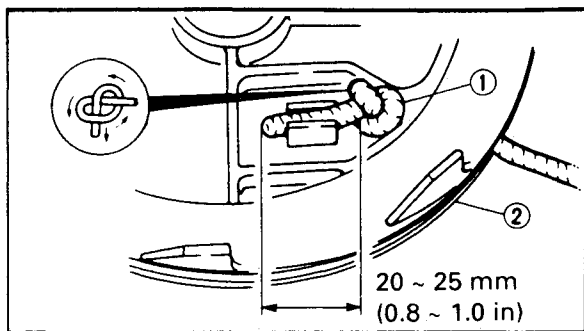

**2. Install:**

- Starter rope ①
- Sheave drum ②

**NOTE:**

Make a knot in the starter rope, leaving a 20 to 25 mm (0.8 to 1.0 in) portion of the rope end.

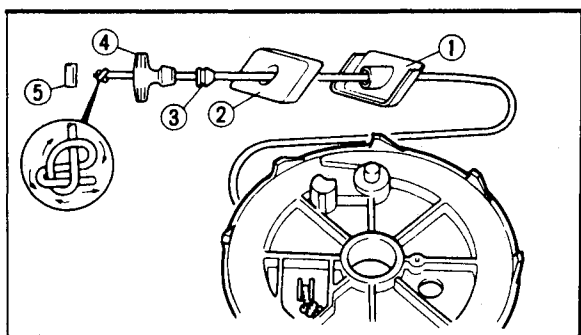

**3. Install:**

- Rope guide ①
- Rubber seal ②
- Damper ③
- Starter handle ④
- Cover ⑤

**NOTE:**

- Insert the rope through the rope holes and knot the end.
- Wind the rope 2-1/2 turns around the sheave drum.
- Place the rope at the cutaway.

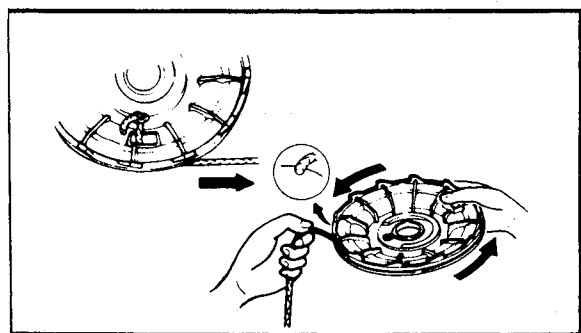

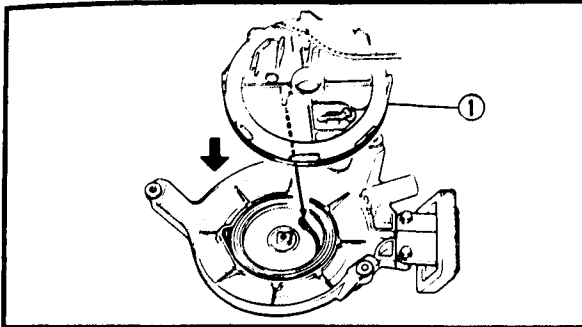

**4. Install:**

- Sheave drum ①

**NOTE:**

Position the inner end of the spiral spring on the retainer post of the sheave drum.

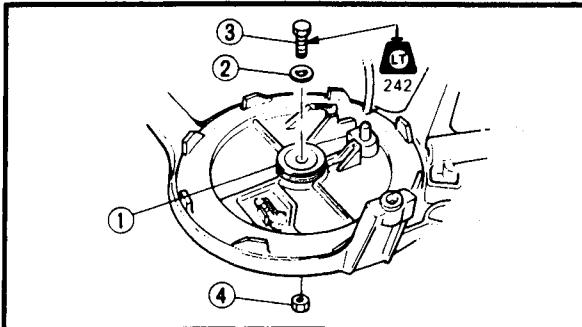

**5. Install:**

- Bushing ①
- Washer ②
- Bolt ③
- Nut ④



**Bolt:**  
4 Nm (0.4 m · kg, 2.9 ft · lb)

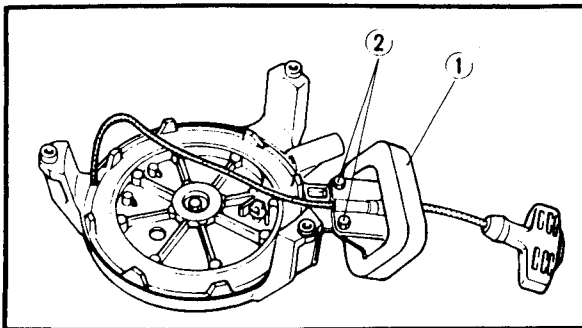

**6. Install:**

- Rope guide ①
- Bolt ②



**Bolt:**  
5 Nm (0.5 m · kg, 3.6 ft · lb)

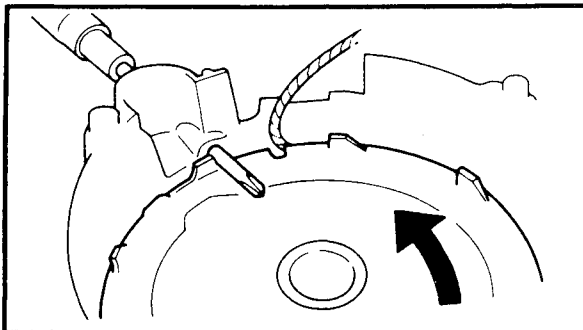

**7. Set:**

- Spiral spring

**NOTE:**

Wind up the spring 3 turns counterclockwise with the starter rope.

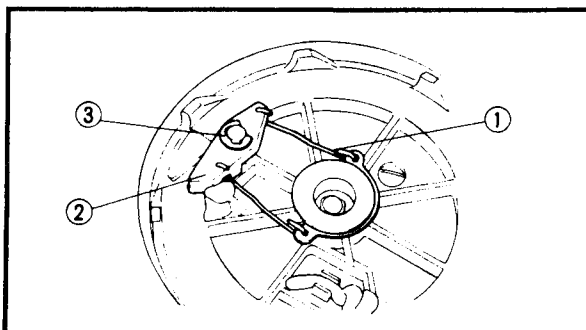

**8. Install:**

- Drive pawl spring ①
- Drive pawl ②
- Circlip ③

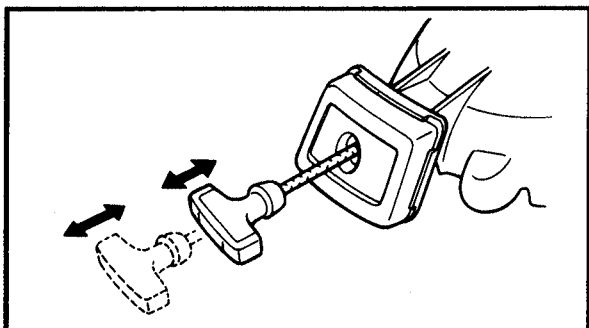
**9. Check:**

- Starter operation  
Rough operation → Repair.

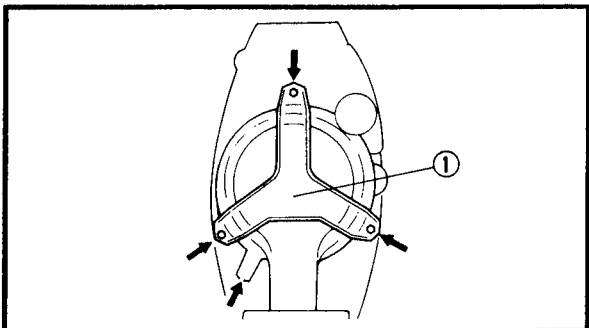
**10. Install:**

- Recoil starter assembly ①
- Bolt
- Start-in-gear protection wire

**11. Adjust:**

- Start-in-gear protection wire  
Refer to page 3-13.

## CHAPTER 6

### LOWER UNIT

<b>LOWER UNIT</b> .....	6-1
<b>PREPARATION FOR REMOVAL</b> .....	6-1
<b>NOTE ON REMOVAL AND REASSEMBLY</b> .....	6-2
<b>REMOVAL POINTS</b> .....	6-3
Shift shaft .....	6-3
Reverse gear complete .....	6-3
Pinion gear .....	6-3
Bushing .....	6-3
Bearing outer race .....	6-4
Reverse gear .....	6-4
Forward gear complete .....	6-5
<b>INSPECTION AND REPAIR</b> .....	6-5
Lower case .....	6-5
Bearing housing .....	6-5
Water pump housing .....	6-6
Impeller .....	6-6
Shift rod.....	6-6
Gear .....	6-6
Bearing .....	6-6
Drive shaft.....	6-7
Propeller shaft.....	6-7
Dog clutch .....	6-7
Sleeve.....	6-7
Propeller/Anode.....	6-7
<b>ASSEMBLY AND INSTALLATION</b> .....	6-8
Forward gear.....	6-8
Propeller shaft.....	6-8
Reverse gear .....	6-8
Oil seal housing .....	6-9
Lower case .....	6-10
Backlash measurement.....	6-11
Water pump .....	6-16
Lower unit .....	6-17
Propeller .....	6-17



**LOWER UNIT  
PREPARATION FOR REMOVAL**

- Drain the gear oil.

A	10 Nm (1.0 m • kg, 7.2 ft • lb)
B	11 Nm (1.1 m • kg, 8.0 ft • lb)
C	17 Nm (1.7 m • kg, 12 ft • lb)

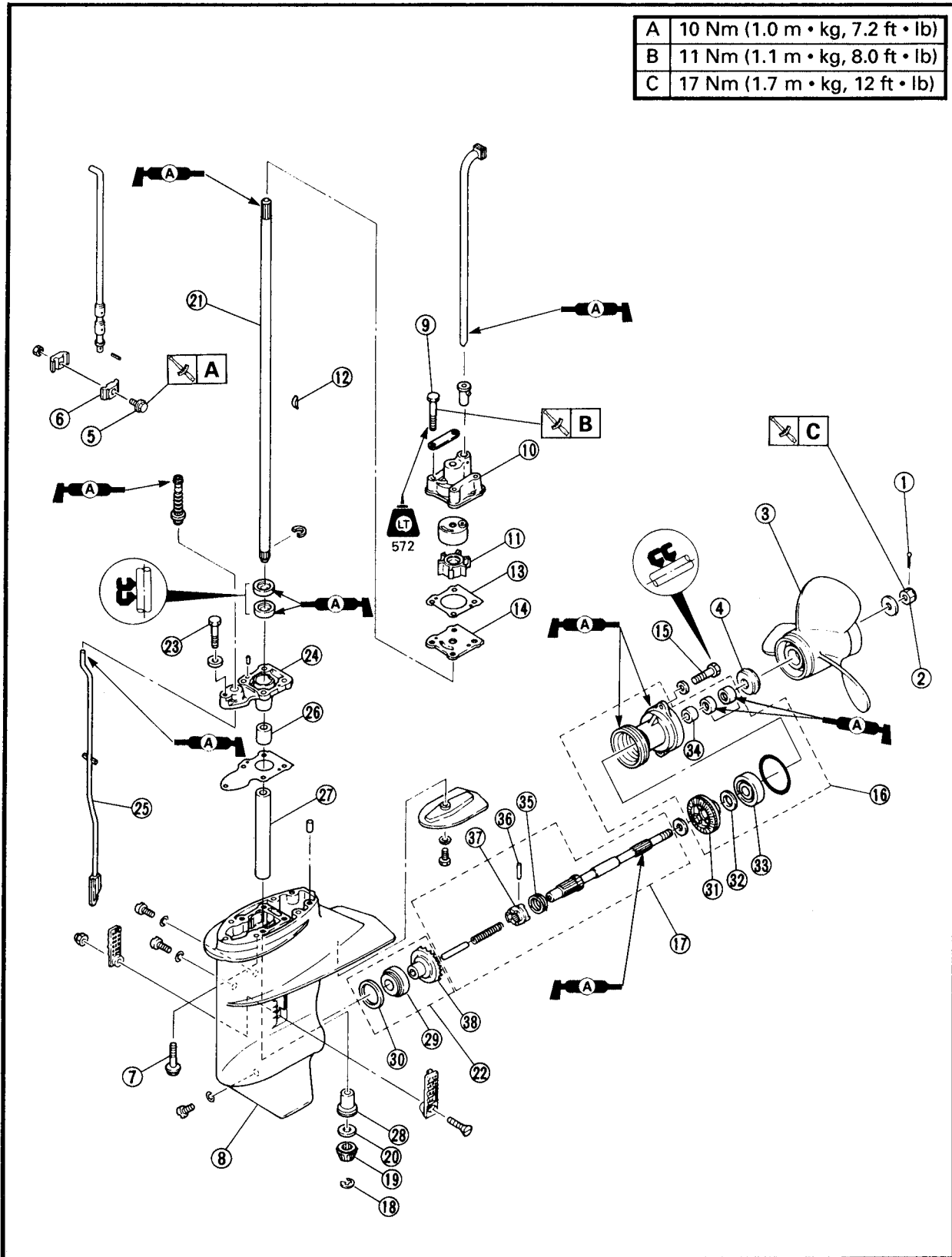



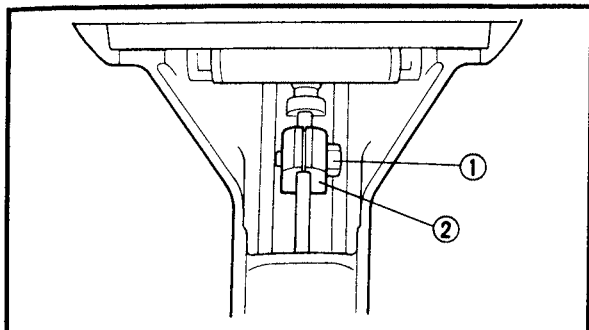

**REMOVAL POINTS**

**Shift shaft**

1. Remove:
  - Bolt ①
  - Shift rod connector ②

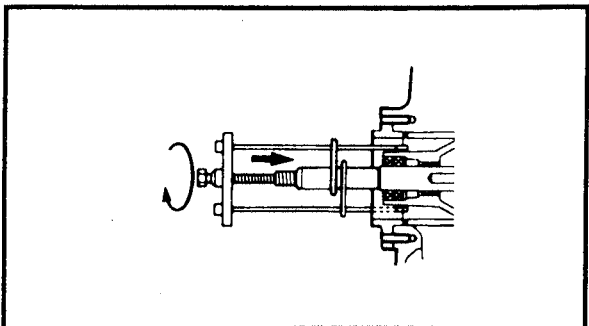

**Reverse gear complete**

1. Remove:
  - Reverse gear complete



**Bearing housing puller:**  
**YB-6234**  
**Universal puller:**  
**YB-6117**

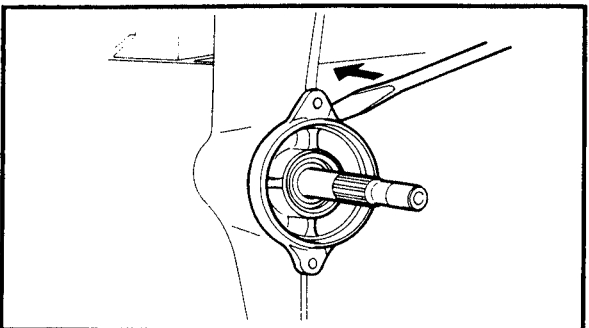

**NOTE:**

Fit a flat-head screwdriver into one of the two notches in the bearing housing flange, and pry the housing off slightly.

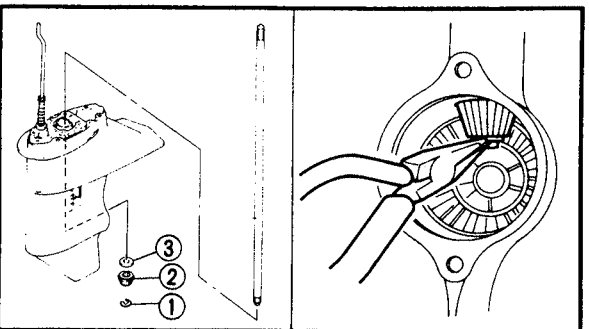

**Pinion gear**

1. Remove:
  - Circlip ①
  - Pinion gear ②
  - Pinion gear shim ③

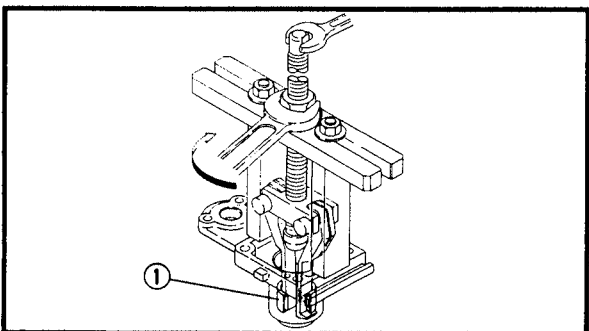

**Bushing**

1. Remove:
  - Bushing ① (oil seal housing)



**Stopper guide plate:**  
**90890-06501**  
**Bearing puller:**  
**90890-06535**  
**Stopper guide stand:**  
**90890-06538**

**LOWR**  **LOWER UNIT**

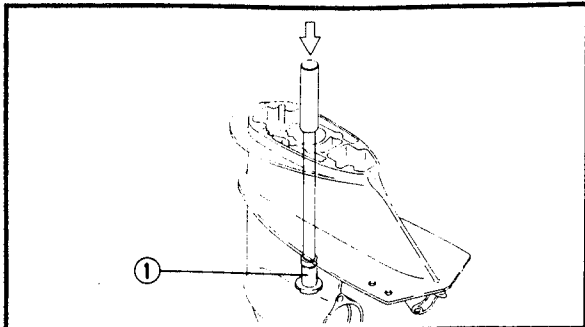

2. Remove:
- Bushing ① (pinion gear)

 **Drive rod:**  
**YB-6229/90890-06652**  
**Bushing attachment:**  
**YB-6028/90890-06650**

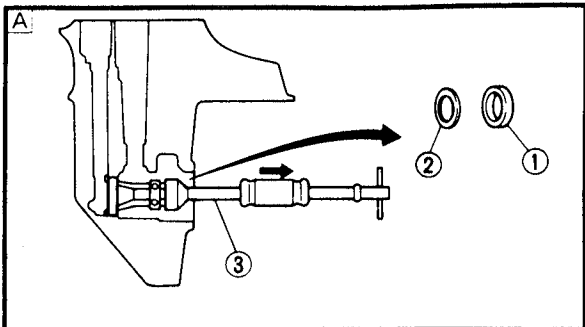

- Bearing outer race**
1. Remove:
- Bearing outer race ①
  - Forward gear shim ②

 **Slide hammer set:**  
**YB-6096** ..... ③  
**Stopper guide plate:**  
**90890-06501** ..... ④  
**Bearing puller:**  
**90890-06535** ..... ⑤  
**Stopper guide stand:**  
**90890-06538** ..... ⑥

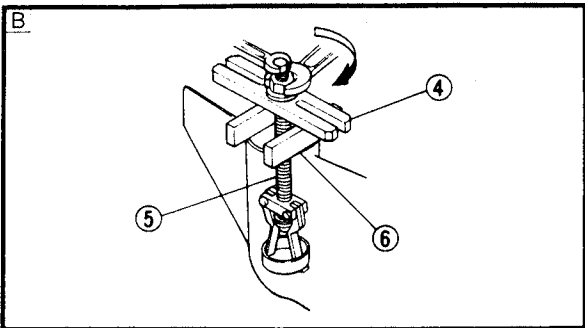

- A** For USA and CANADA  
**B** Except for USA and CANADA

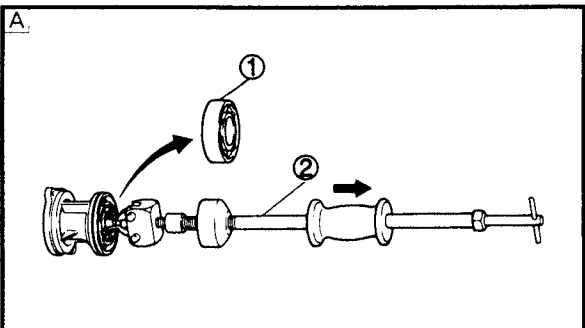

- Reverse gear**
1. Remove:
- Ball bearing ①

 **Slide hammer set:**  
**YB-6096** ..... ②  
**Stopper guide plate:**  
**90890-06501** ..... ③  
**Bearing puller:**  
**90890-06535** ..... ④  
**Stopper guide stand:**  
**90890-06538** ..... ⑤

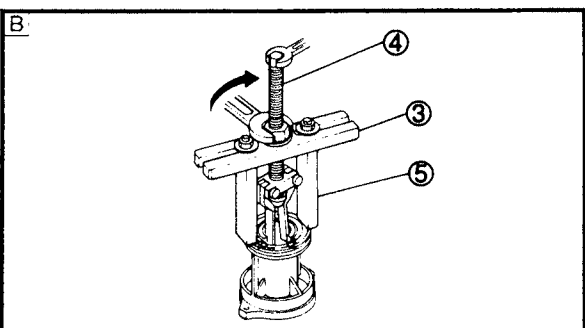

- A** For USA and CANADA  
**B** Except for USA and CANADA

**LOWR**



**LOWER UNIT**

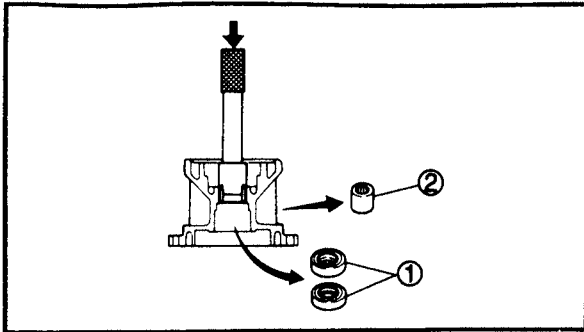

2. Remove:

- Oil seal ①
- Bushing ②



**Drive rod:**

**/90890-06652**

**Bushing attachment:**

**/90890-06649**

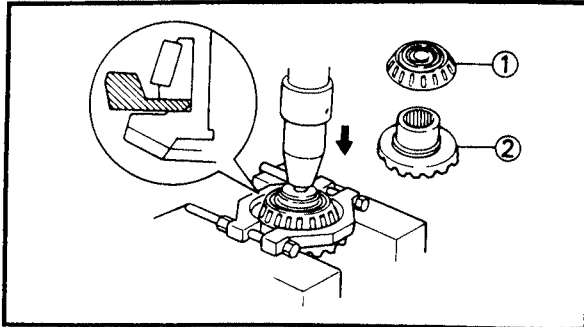

**Forward gear complete**

1. Remove:

- Taper roller bearing ①
- Forward gear ②



**Bearing separator:**

**YB-6219/90890-06534**

## **INSPECTION AND REPAIR**

### **Lower case**

1. Clean:

- Gear case  
Use a soft brush and solvent.

2. Inspect:

- Water passage  
Mineral deposits/Corrosion → Clean.

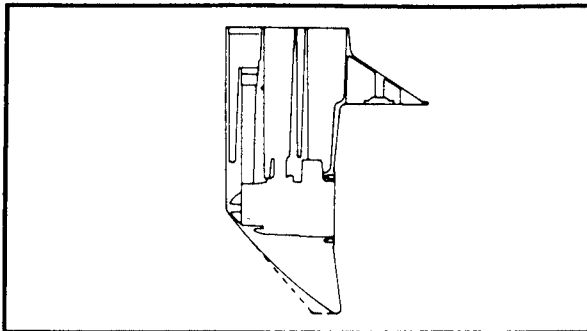

3. Inspect:

- Lower case  
Crack/Damage → Replace.

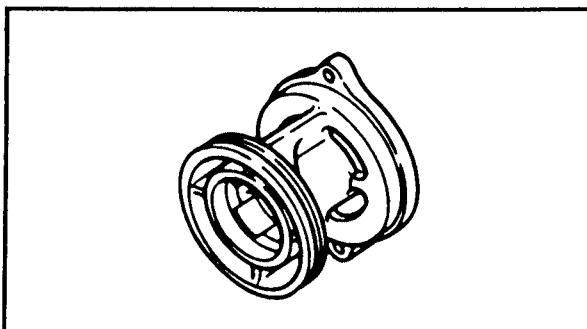

### **Bearing housing**

1. Clean:

- Bearing housing  
Use a soft brush and solvent.

2. Inspect:

- Bearing housing  
Crack/Damage → Replace.

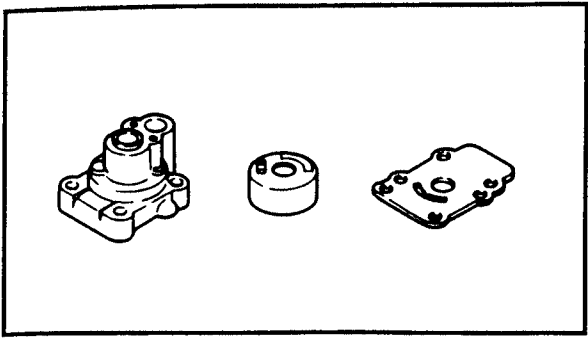

**Water pump housing**

- 1. Inspect:
  - Water pump housing  
Crack/Damage → Replace.

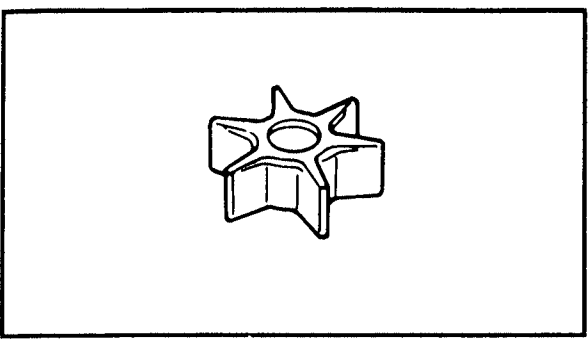

**Impeller**

- 1. Inspect:
  - Impeller  
Crack/Damage → Replace.

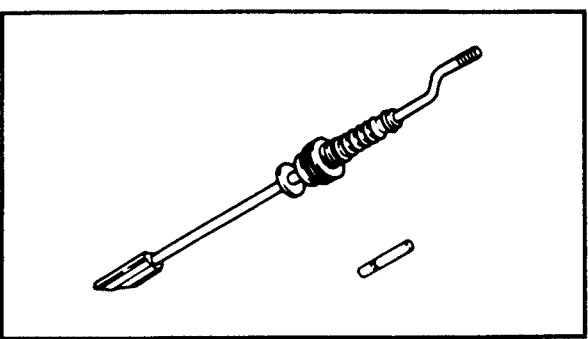

**Shift rod**

- 1. Inspect:
  - Shift plunger  
Wear/Damage → Replace.
- 2. Inspect:
  - Boot  
Break/Damage → Replace.

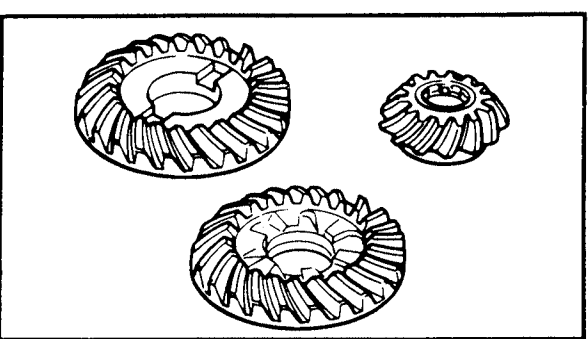

**Gear**

- 1. Inspect:
  - Teeth
  - Dogs  
Wear/Damage → Replace.

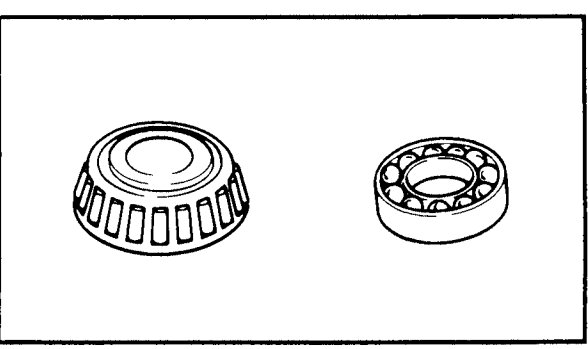

**Bearing**

- 1. Inspect:
  - Bearing  
Pitting/Rumbling → Replace.

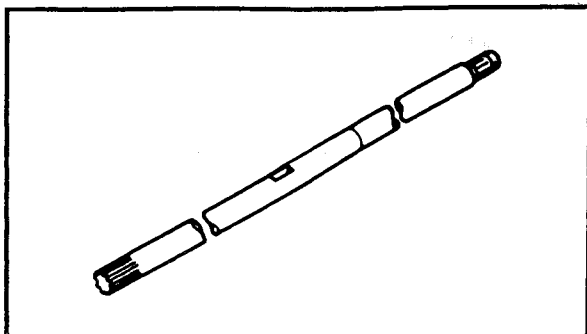
**Drive shaft**

## 1. Inspect:

- Drive shaft  
Wear/Damage → Replace.

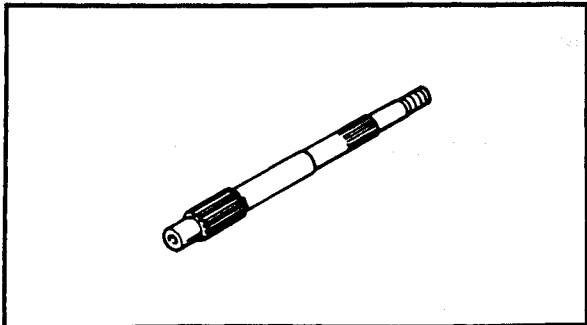
**Propeller shaft**

## 1. Inspect:

- Propeller shaft  
Wear/Damage → Replace.

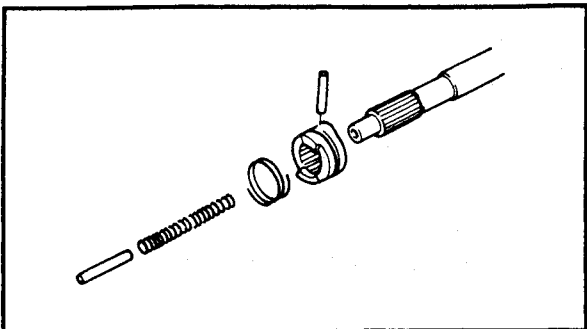
**Dog clutch**

## 1. Inspect:

- Dog clutch  
Wear/Damage → Replace.

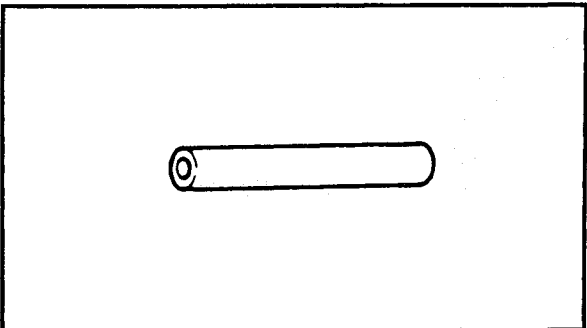
**Sleeve**

## 1. Inspect:

- Sleeve  
Wear/Damage → Replace.

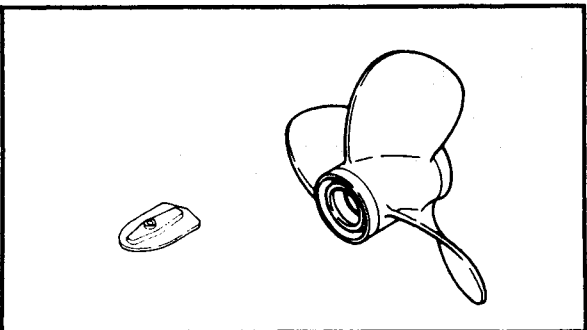
**Propeller/Anode**

Refer to page 3-8.

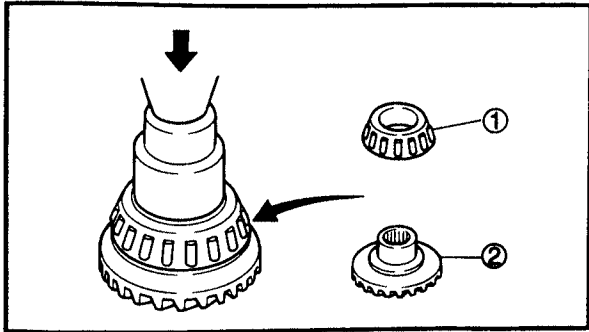

**ASSEMBLY AND INSTALLATION**

**Forward gear**

1. Install:
- Taper roller bearing ①
  - Forward gear ②

	<b>Bearing inner race attachment:</b> <b>/90890-06645</b>
--	--

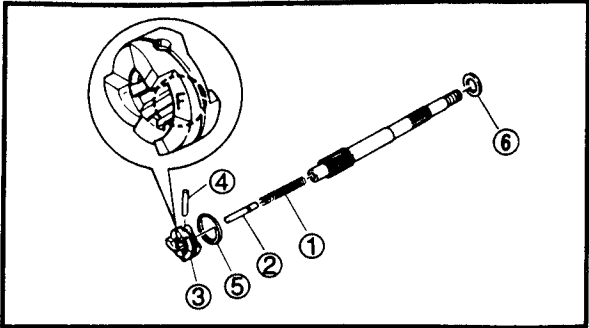

**Propeller shaft**

1. Install:
- Spring ①
  - Plunger ②
  - Dog clutch ③
  - Cross pin ④
  - Cross pin ring ⑤
  - Washer ⑥

**NOTE:** \_\_\_\_\_  
Install the clutch with "F" mark toward the forward gear side.  
\_\_\_\_\_

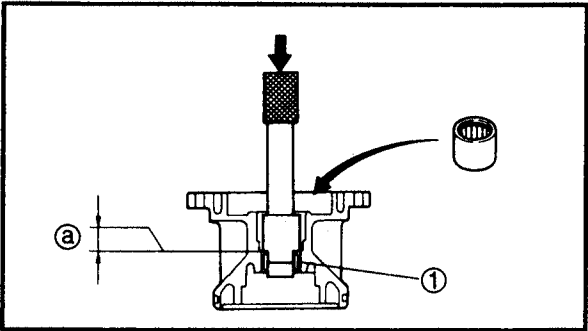

**Reverse gear**

1. Install:
- Bushing ①

	<b>Drive rod:</b> <b>/90890-06652</b>
	<b>Bushing attachment:</b> <b>/90890-06649</b>

	<b>Depth @:</b> <b>0 mm (0 in)</b>
--	---------------------------------------



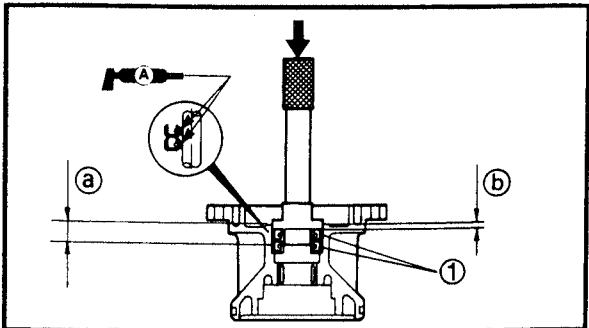

2. Install:

- Oil seal ①



**Oil seal installer:**  
YB-6021  
**Drive rod:**  
YB-6229



**Depth a):**  
10.0 ~ 10.5 mm (0.39 ~ 0.41 in)  
**Depth b):**  
3.0 ~ 3.5 mm (0.12 ~ 0.14 in)

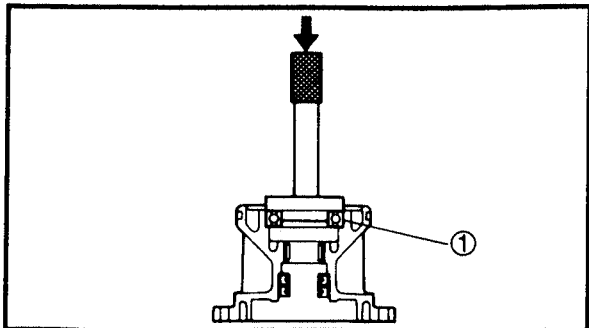

3. Install:

- Ball bearing ①



**Bearing installer:**  
YB-6015/90890-06634  
**Drive rod:**  
YB-6071/90890-06606

**NOTE:**

Install the bearing with its manufacturer's marks or numbers facing outward.

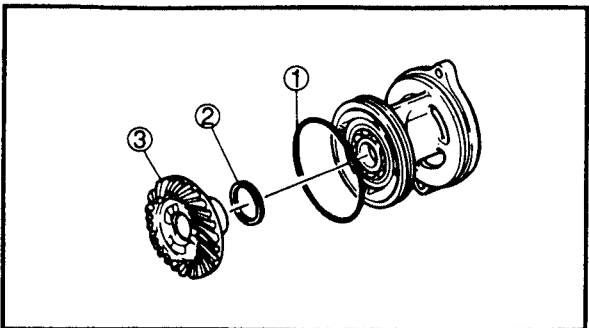

4. Install:

- O-ring ①
- Reverse gear shim ②
- Reverse gear ③

**Oil seal housing**

1. Install:

- Bushing ①



**Bushing attachment:**  
YB-6028/90890-06650  
**Drive rod:**  
YB-6229/90890-06652



**Depth a):**  
5 mm (0.20 in)

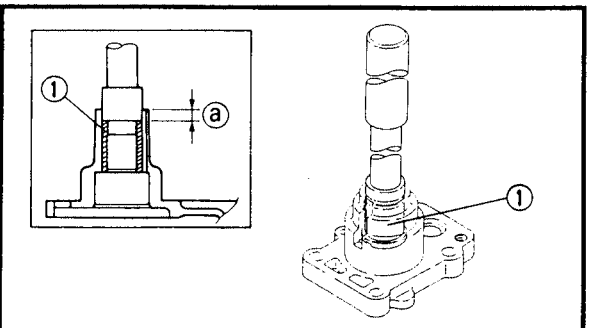

2. Install:

- Oil seal ①



**Depth a):**  
3.0 ~ 3.5 mm (0.12 ~ 0.14 in)

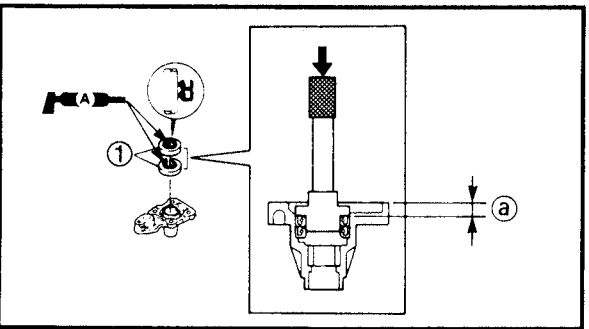

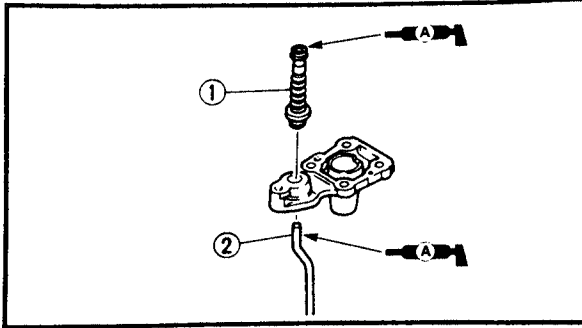

**3. Install:**

- Boot ①
- Shift shaft ②

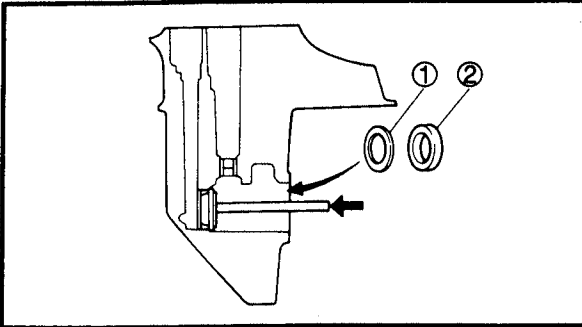

**Lower case**

**1. Install:**

- Forward gear shim ①
- Bearing outer race ②



**Bearing installer:**  
**YB-6167/90890-06628**  
**Drive rod:**  
**YB-6071/90890-06605**

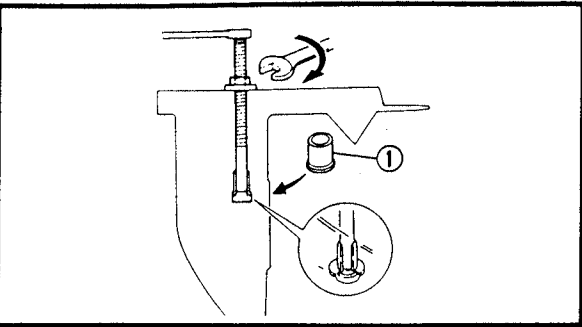

**2. Install:**

- Bushing ①



**Bushing installer:**  
**YB-6029/90890-06601**  
**Needle bearing installer:**  
**YB-6169**  
**Bushing attachment:**  
**YB-6028/90890-06650**

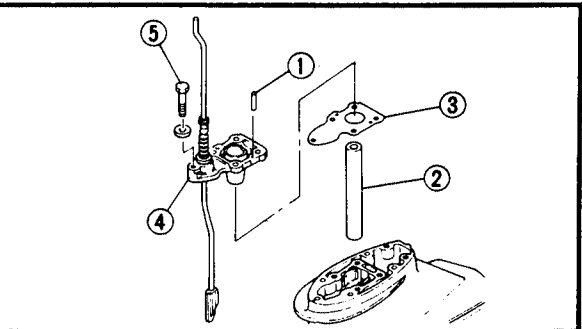

**3. Install:**

- Dowel pin ①
- Sleeve ②
- Gasket ③
- Oil seal housing ④
- Bolt ⑤

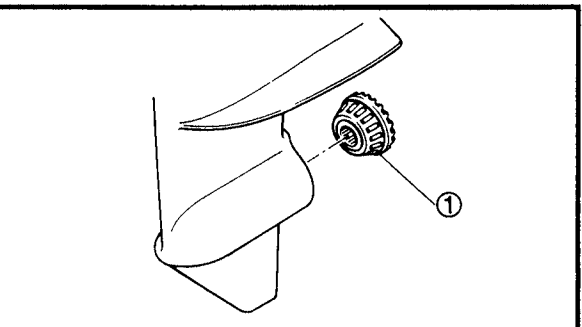

**4. Install:**

- Forward gear complete ①

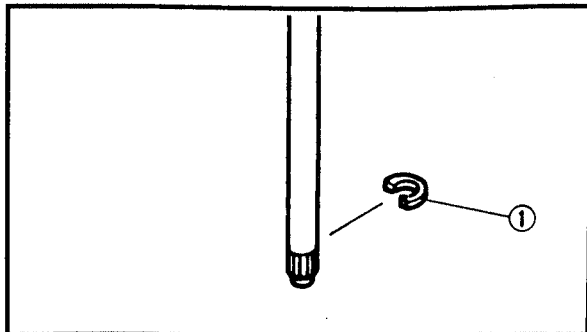

5. Install:
- Crip ①

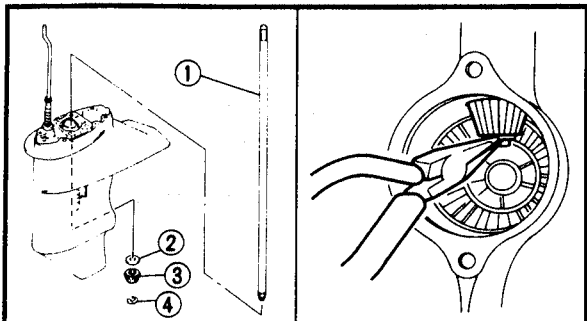

6. Install:
- Drive shaft ①
  - Pinion gear shim ②
  - Pinion gear ③
  - Circlip ④

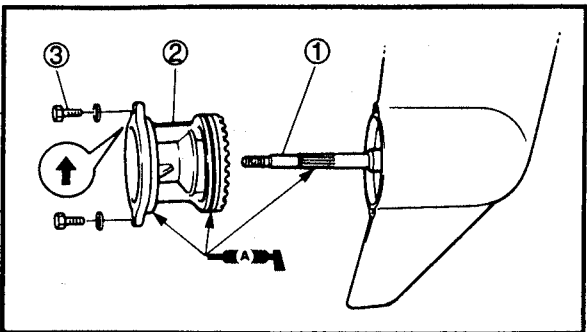

7. Install:
- Propeller shaft complete ①
  - Reverse gear complete ②
  - Bolt ③

**NOTE:** \_\_\_\_\_  
Face the arrow mark "↑" upward.

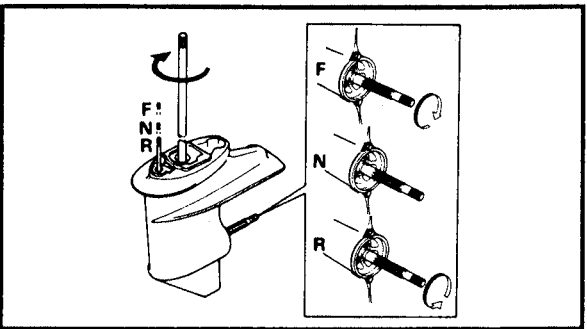

8. Check:
- Shift cam operation
- Rough operation → Repair.

**NOTE:** \_\_\_\_\_  
Check that the dog clutch shifts to "Forward", "Neutral" and "Reverse" correctly.

**Backlash measurement**

- NOTE:** \_\_\_\_\_
- Both forward and reverse gear backlash should be measured.
  - If both the forward and reverse gear backlash are larger than specified, the pinion may be too high.

- If both the forward and reverse gear backlash are smaller than specified, the pinion may be too low.
- If either of these conditions exists, then check the pinion shim selection.

1. Measure:

- Forward gear backlash  
Out of specification → Adjust.

	<p><b>Backlash:</b> 0.25 ~ 0.75 mm</p>
--	--

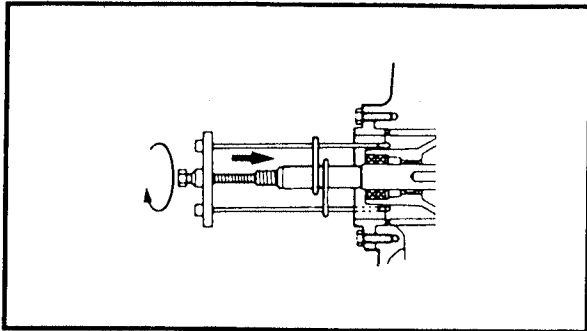

**Measuring steps:**

- Place the shift shaft in neutral.
- Load the forward gear with the bearing housing puller on the propeller shaft.

**NOTE:**



Lightly tighten by hand until the pressure of the propeller shaft on the forward gear restricts movement enough to allow backlash measurement.

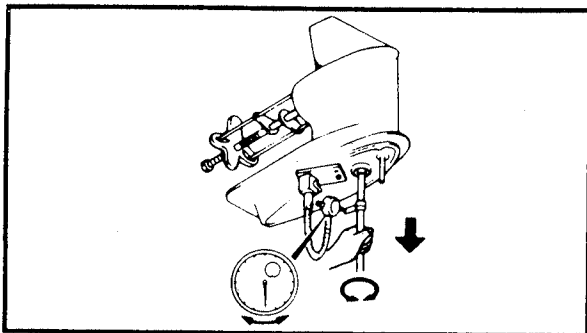

**Bearing housing puller:**  
YB-6234  
**Universal puller:**  
YB-6117



- Set the lower unit upside down.
- Attach the backlash indicator on the drive shaft.
- Attach the dial gauge on the gear case, and make the dial gauge stem contact the mark on the indicator.

	<b>Dial gauge:</b> YU-3097/90890-01252 <b>Magnet base:</b> YU-34481/90890-06705 <b>Backlash indicator:</b> YB-6265/90890-06265
<ul style="list-style-type: none"> <li>● While pulling the drive shaft downward, slowly turn the drive shaft clockwise and counterclockwise then measure the backlash when the drive shaft stops at each direction.</li> <li>● Determine the shims to be added or removed according to the specified.</li> </ul>	
Less than 0.25 mm	To be decreased by $\frac{(0.50 - \text{measurement})}{1.6}$
More than 0.75 mm	To be increased by $\frac{(\text{measurement} - 0.50)}{1.6}$
<p><b>Example:</b></p> If measurement = 0.20 mm Decrease shim thickness by $= (0.50 - 0.20)/1.6$ $= 0.30/1.6 = 0.18 \text{ mm}$ If measurement = 0.82 mm Increase shim thickness by $= (0.82 - 0.50)/1.6$ $= 0.32/1.6 = 0.20 \text{ mm}$	
	<b>Available shim thickness:</b> 0.10, 0.12, 0.15, 0.18, 0.30, 0.40 and 0.50 mm

**NOTE:** \_\_\_\_\_  
 Since the smallest shim available is 0.10 mm, if the measurement is between 0.25 and 0.75 mm do not change the shim.

**LOWR**  **LOWER UNIT**

2. Measure:

- Reverse gear backlash  
Out of specification → Adjust.

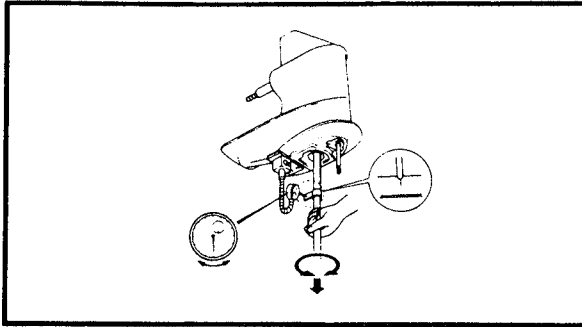
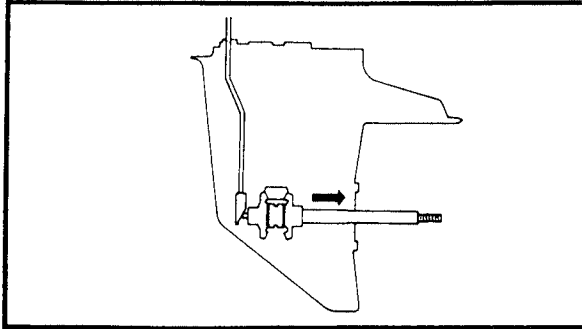

**Backlash:**  
0.25 ~ 0.75 mm

**Measuring steps:**

- Place the shift shaft in neutral.
- Set the lower unit upside down.
- Attach the backlash indicator on the drive shaft.
- Attach the dial gauge on the gear case, and make the dial gauge stem contact the mark on the indicator.



**Dial gauge:**  
YU-3097/90890-01252  
**Magnet base:**  
YU-34481/90890-06705  
**Backlash indicator:**  
YB-6265/90890-06265

- While pulling the drive shaft downward, slowly turn the drive shaft clockwise and counterclockwise then measure the backlash when the drive shaft stops at each direction.
- Determine the shims to be added or removed according to the specified.

Less than  
0.25 mm

To be decreased by  
(0.50 – measurement)  
1.6

More than  
0.75 mm

To be increased by  
(measurement – 0.50)  
1.6

**Example:**

If measurement = 0.15 mm  
Increase shim thickness by

$$= (0.50 - 0.15)/1.6$$

$$= 0.35/1.6 = 0.22 \approx 0.20 \text{ mm}$$

If measurement = 0.85 mm  
Decrease shim thickness by

$$= (0.85 - 0.50)/1.6$$

$$= 0.35/1.6 = 0.22 \approx 0.20 \text{ mm}$$



## LOWER UNIT

---



**Available shim thickness:  
0.10 mm**

**NOTE:** \_\_\_\_\_  
Since the smallest shim available is 0.10 mm, if the measurement is between 0.25 and 0.75 mm do not change the shim.

---

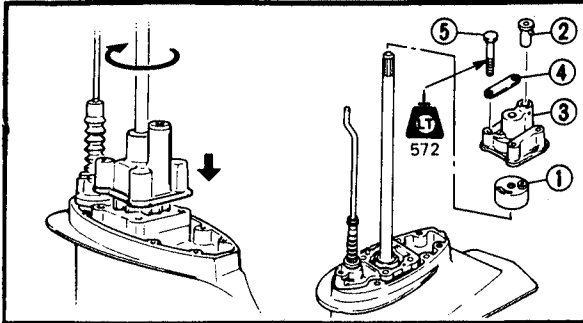
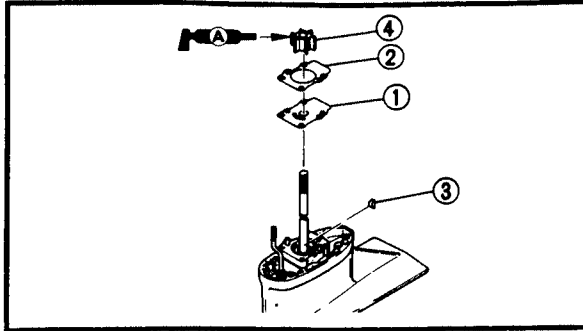

**Water pump**

**1. Install:**

- Outer plate ①
- Gasket ②
- Woodruff key ③
- Impeller ④

**2. Install:**

- Insert cartridge ①
- Bushing ②
- Water pump housing ③
- Plate ④
- Bolt ⑤

**NOTE:**

- Apply the impeller with water resistant grease.
- Align the hole in the water pump housing with the projection in the insert cartridge, when assembling them.
- Turn the drive shaft clockwise, when installing the water pump housing.
- Apply Loctite (572) to the bolts.

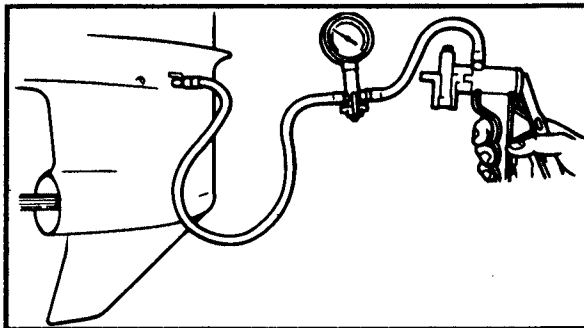

**Bolt:**  
11 Nm (1.1 m · kg, 8.0 ft · lb)

**3. Check:**

- Leakage  
Leak → Reinstall.

**Checking steps:**

- Attach the Mity Vac to the oil level hole.



**Mity Vac:**  
YB-35956/90890-06756

- Apply the specified pressure.



**Specified pressure:**  
100 kpa (1.0 kg/cm<sup>2</sup>, 14.2 psi)

- Check that the pressure is held for 10 seconds.



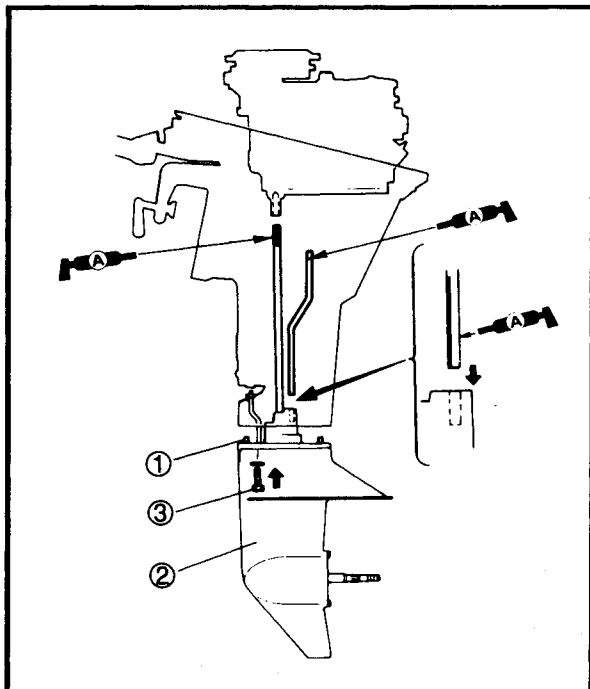

**Lower unit**

**1. Install:**

- Dowel pin ①
- Lower unit ②
- Bolt ③

**NOTE:**

- Shift the gear in reverse.
- Insert the drive shaft into the crankshaft, insert the water tube into the water seal, and insert the shift rod into the upper casing.

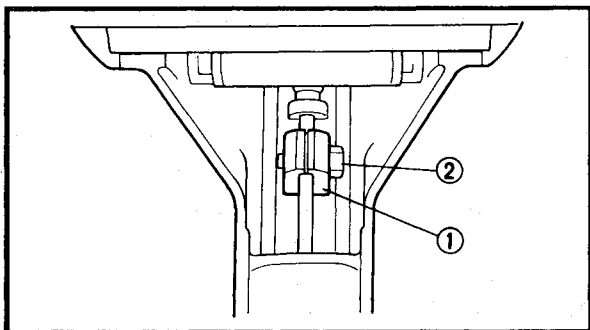

**2. Install:**

- Shift rod connector ①
- Bolt ②



**Bolt:**  
10 Nm (1.0 m • kg, 7.2 ft • lb)

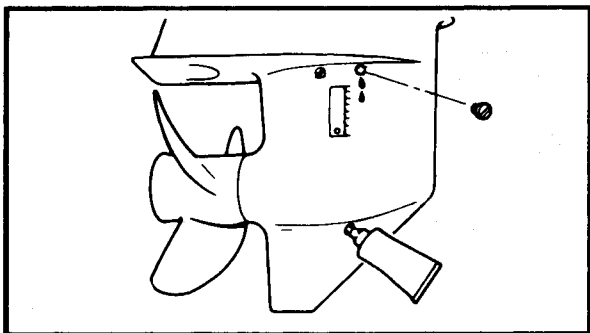

**3. Apply:**

- Gear oil
- Refer to page 3-10.

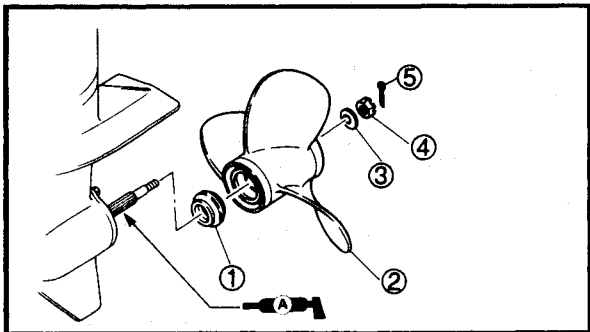

**Propeller**

**1. Install:**

- Spacer ①
- Propeller ②
- Washer ③
- Nut ④
- Cotter pin ⑤



**Nut:**  
17 Nm (1.7 m • kg, 12 ft • lb)

## CHAPTER 7 BRACKET UNIT

<b>UPPER CASING AND BOTTOM COWLING .....</b>	<b>7-1</b>
<b>PREPARATION FOR REMOVAL .....</b>	<b>7-1</b>
<b>INSPECTION AND REPAIR .....</b>	<b>7-2</b>
Shift mechanism.....	7-2
Bottom cowling .....	7-2
Clamp lever.....	7-3
Sealing parts.....	7-3
Mount rubber.....	7-3
Upper casing.....	7-3
<b>ASSEMBLY AND INSTALLATION.....</b>	<b>7-4</b>
Upper casing.....	7-4
Bottom cowling .....	7-5
<b>BRACKET UNIT .....</b>	<b>7-7</b>
<b>PREPARATION FOR REMOVAL .....</b>	<b>7-7</b>
<b>INSPECTION .....</b>	<b>7-8</b>
Steering bracket and pivot shaft .....	7-8
Clamp and swivel bracket.....	7-8
Tilt plate.....	7-9
<b>ASSEMBLY AND INSTALLATION.....</b>	<b>7-9</b>
<b>STEERING HANDLE.....</b>	<b>7-11</b>
<b>PREPARATION FOR REMOVAL .....</b>	<b>7-11</b>
<b>INSPECTION .....</b>	<b>7-12</b>
Throttle shaft.....	7-12
Bushing .....	7-12
Friction piece.....	7-12
Steering handle .....	7-12
<b>ASSEMBLY AND INSTALLATION.....</b>	<b>7-13</b>
Steering handle .....	7-13

**UPPER CASING AND BOTTOM COWLING  
PREPARATION FOR REMOVAL**

- Remove the power unit.
- Remove the lower unit.

A	3 Nm (0.3 m • kg, 2.2 ft • lb)
B	4 Nm (0.4 m • kg, 2.9 ft • lb)
C	6 Nm (0.6 m • kg, 4.3 ft • lb)
D	10 Nm (1.0 m • kg, 7.2 ft • lb)

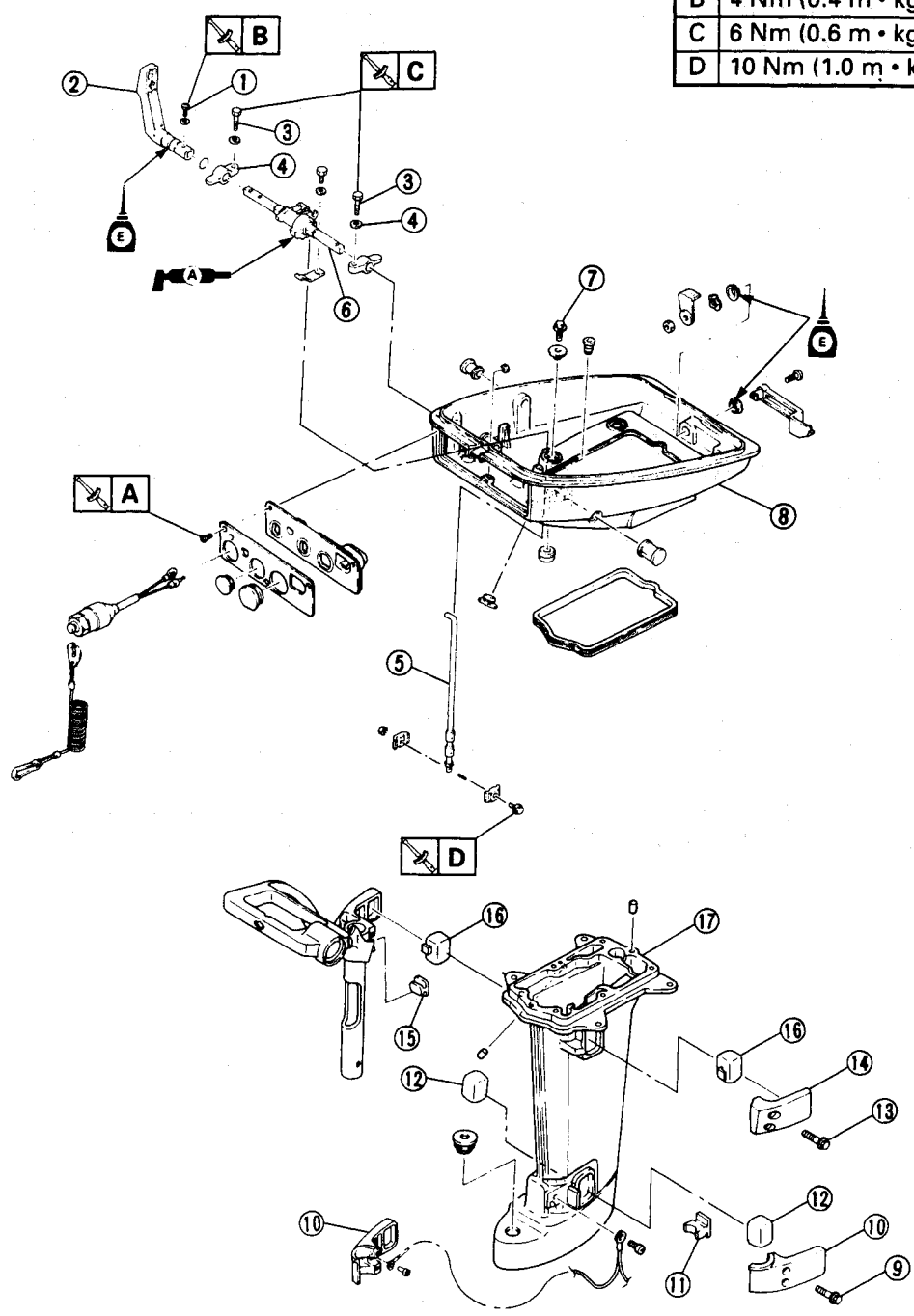

Extent of removal: ① Bottom cowling removal      ② Mount rubber removal  
 ③ Upper casing disassembly

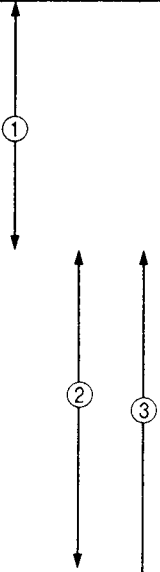
Extent of removal	Order	Part name	Q'ty	Remarks
	1	Screw	1	
	2	Shift handle	1	
	3	Bolt	2	
	4	Bracket	2	
	5	Shift rod	1	
	6	Shift rod lever	1	
	7	Bolt	4	
	8	Bottom cowling	1	
	9	Bolt	2	
	10	Lower mount rubber housing	2	
	11	Lower front mount rubber	1	
	12	Lower side mount rubber	2	
	13	Bolt	2	
	14	Upper mount rubber housing	1	
	15	Upper front mount rubber	1	
	16	Upper side mount rubber	2	
	17	Upper casing	1	

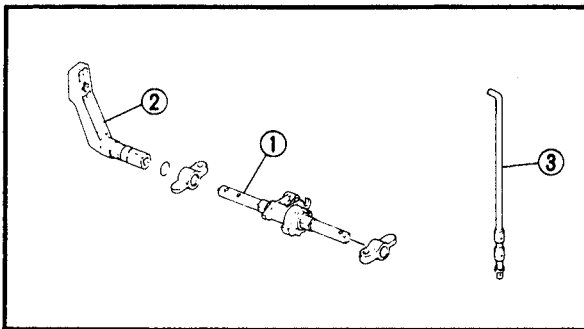

**INSPECTION AND REPAIR**

**Shift mechanism**

1. Inspect:

- Shift rod lever ①
- Shift handle ②
- Shift rod ③

Wear/Bend/Damage → Replace.

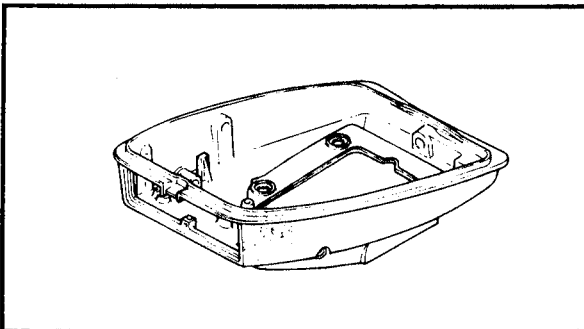

**Bottom cowling**

1. Inspect:

- Bottom cowling

Crack/Damage → Replace.

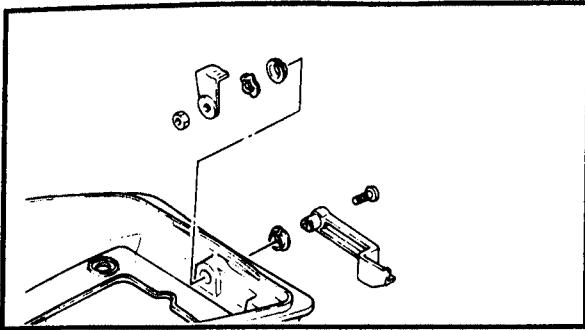
**Clamp lever**

## 1. Inspect:

- Clamp lever  
Wear/Damage → Replace.

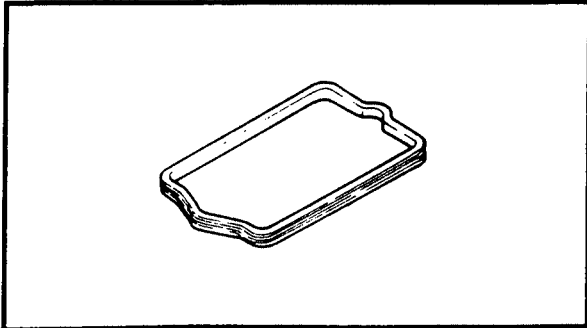
**Sealing parts**

## 1. Inspect:

- Rubber seal  
Crack/Damage → Replace.

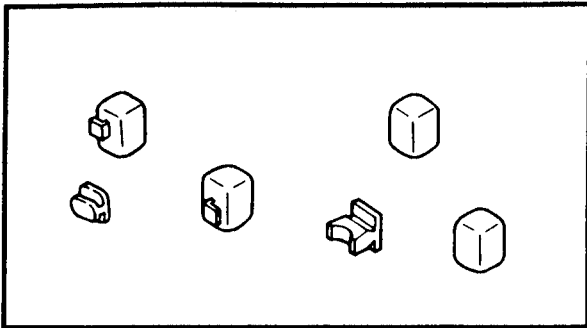
**Mount rubber**

## 1. Inspect:

- Mount rubber  
Wear/Damage → Replace.

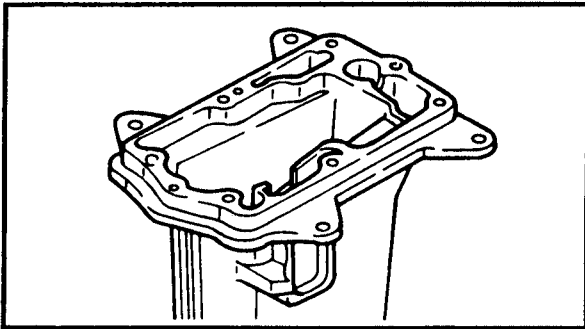
**Upper casing**

## 1. Inspect:

- Upper casing  
Crack/Damage → Replace.

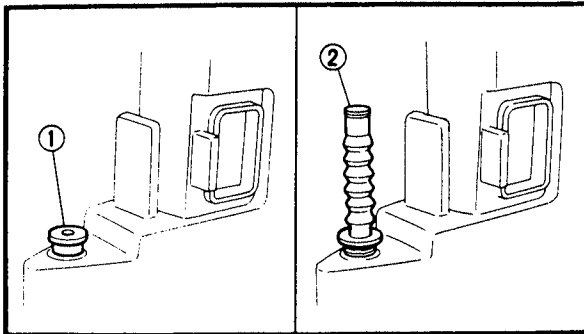
**ASSEMBLY AND INSTALLATION****Upper casing****1. Install:**

- Grommet ① (short transom model)
- Boot ② (long transom model)

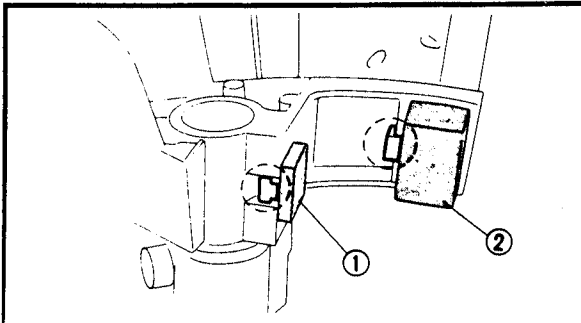
**2. Install:**

- Upper front mount rubber ①
- Upper side mount rubber ②

**NOTE:** \_\_\_\_\_

Hook the upper side mount rubber on to the housing rib.

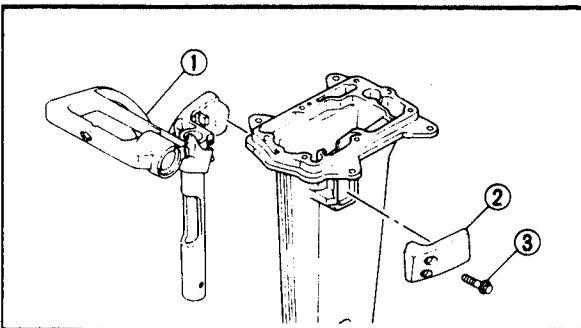
**3. Install:**

- Steering bracket ①
- Upper mount rubber housing ②
- Bolt ③

**NOTE:** \_\_\_\_\_

On the long transom model, the upper casing boot should be fit over the pivot shaft.

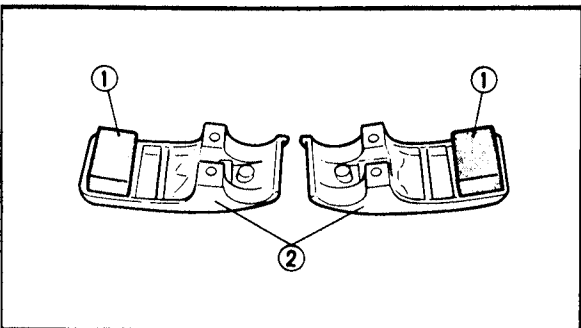
**4. Install:**

- Lower side mount rubber ①
- Lower mount rubber housing ②
- Lower front mount rubber ③

**NOTE:** \_\_\_\_\_

The lower front mount rubber should be set between the two bolts.

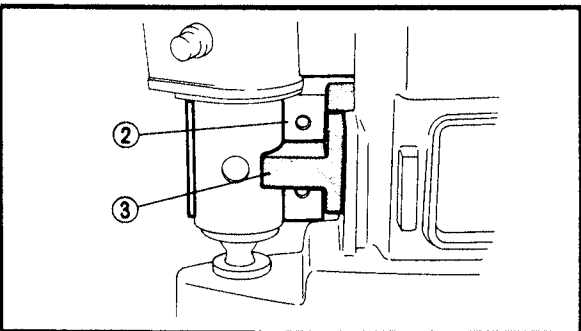

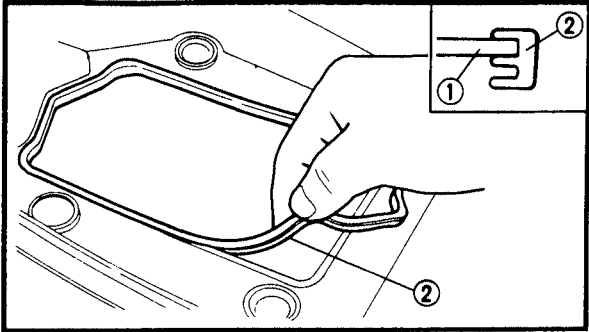

**Bottom cowling**

**1. Install:**

- Bottom cowling ①
- Seal rubber ②

**NOTE:**

The rubber seal should be so installed that its lip faces downward.

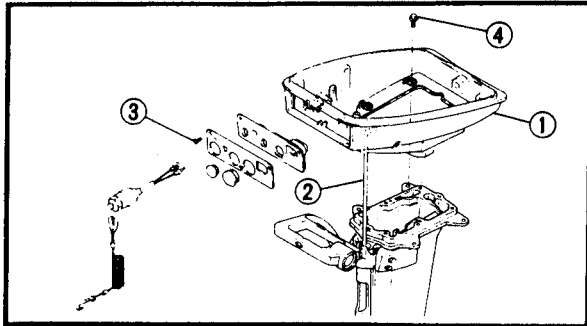

**2. Install:**

- Bottom cowling ①
- Shift rod ②
- Screw ③
- Bolt ④



**Screw:**

**3 Nm (0.3 m · kg, 2.2 ft · lb)**

**NOTE:**

When placing the bottom cowling on the upper casing, use care so that the rubber seal does not come off the bottom cowling.

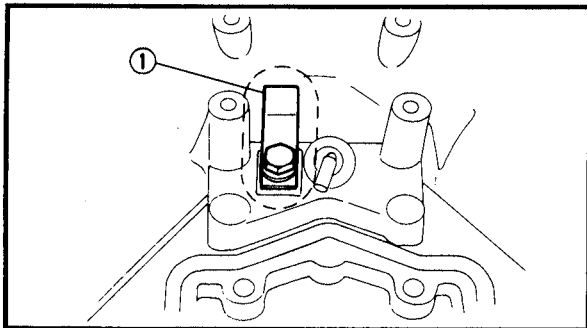

**3. Install:**

- Shift spring ①

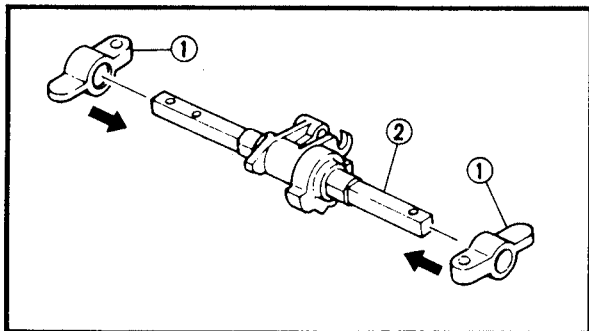

**4. Install:**

- Bracket ①
- Shift rod lever ②

**NOTE:**

The brackets should be so positioned that their round corner sides face outward.

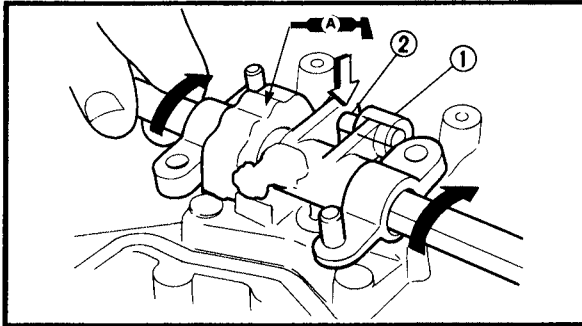

## 5. Install:

- Shift rod lever ①
- Shift rod ②
- Bolt ③

## NOTE:

- Insert the shift rod into the hole in the other arm.
- Turn the shift rod lever 180° backward.

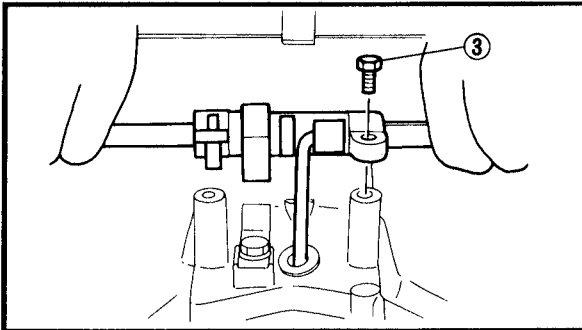
**Bolt:**

**6 Nm (0.6 m · kg, 4.3 ft · lb)**

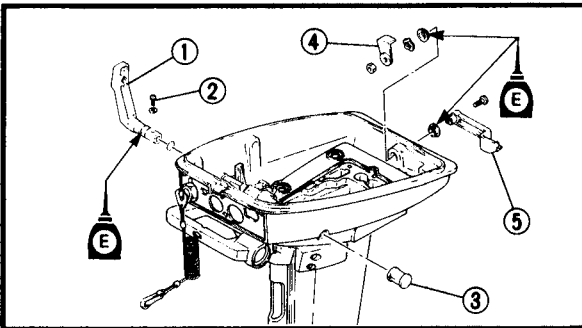

## 6. Install:

- Shift handle ①
- Screw ②
- Grommet ③
- Clamp hook ④
- Clamp lever ⑤

**Screw:**

**4 Nm (0.4 m · kg, 2.9 ft · lb)**



**BRACKET UNIT****PREPARATION FOR REMOVAL**

- Remove the power unit.
- Remove the upper casing and bottom cowling.

A	5 Nm (0.5 m • kg, 3.6 ft • lb)
B	7 Nm (0.7 m • kg, 5.1 ft • lb)

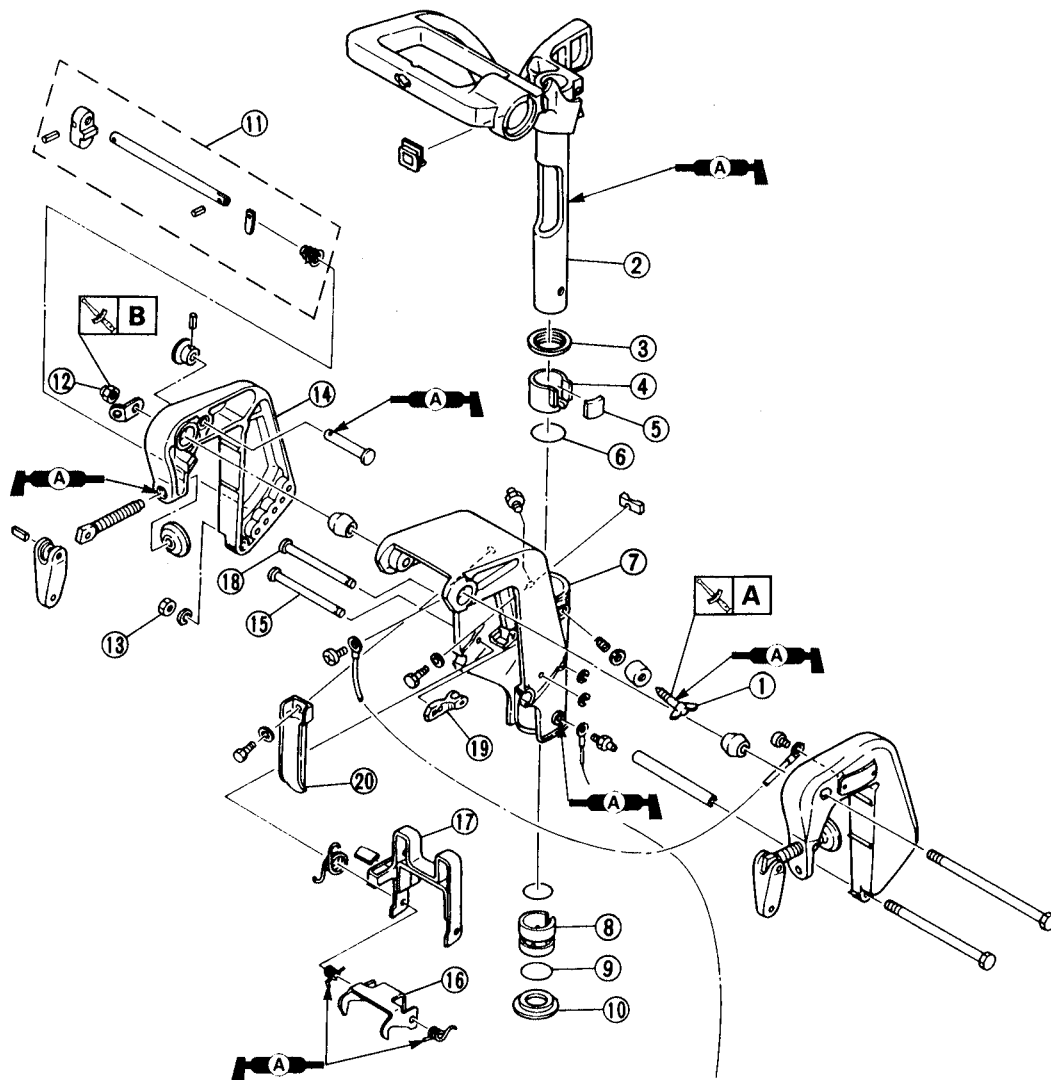



# BRACKET UNIT

Extent of removal: ① Swivel bracket removal ② Clamp bracket removal  
③ Swivel bracket disassembly

Extent of removal	Order	Part name	Q'ty	Remarks	
	1	Bolt	1		
	2	Steering bracket	1		
	3	Washer	1		
	4	Bushing	1		
	5	Friction plate	1		
		6	O-ring	1	
		7	Swivel bracket	1	
		8	Bushing	1	
		9	O-ring	1	
		10	Bushing	1	
	11	Tilt pin	1		
	12	Nut	1		
	13	Nut	1		
	14	Clamp bracket	2		
	15	Pin	1		
	16	Tilt plate (inner)	1		
	17	Tilt plate (outer)	1		
	18	Pin	1		
	19	Drive lever	1		
	20	Carrying handle	1		

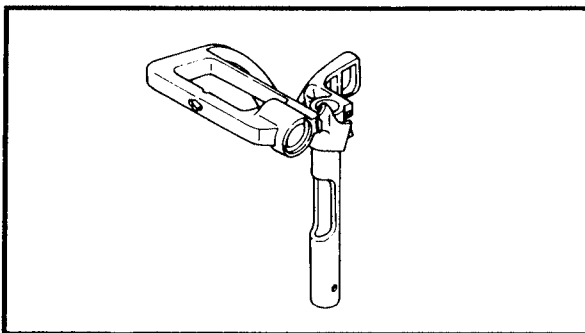

## INSPECTION

### Steering bracket and pivot shaft

1. Inspect:

- Steering bracket
  - Pivot shaft
- Crack/Damage → Replace.

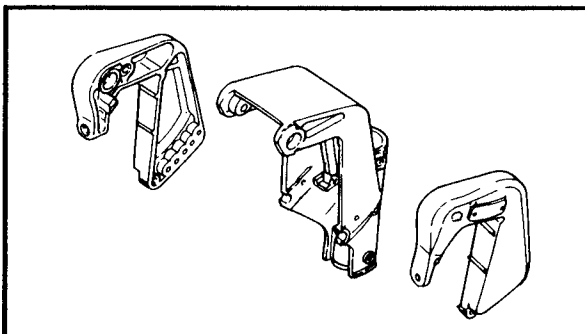

### Clamp and swivel bracket

1. Inspect:

- Clamp bracket
  - Swivel bracket
- Crack/Damage → Replace.

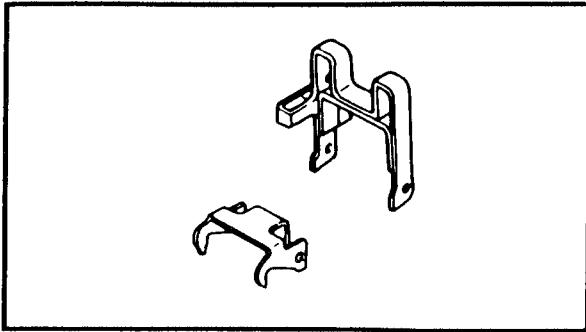
**Tilt plate****1. Inspect:**

- Tilt plate
- Crack/Damage → Replace.

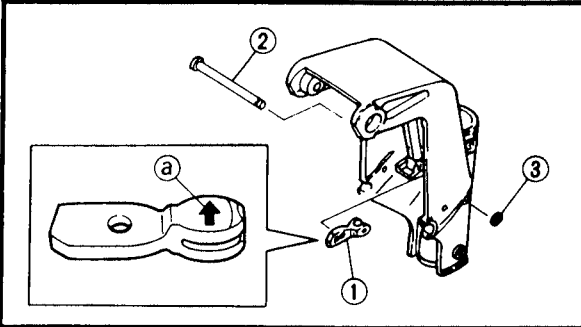
**ASSEMBLY AND INSTALLATION****1. Install:**

- Drive lever ①
- Pin ②
- Crip ③

**NOTE:**

Face the arrow mark (a) upward.

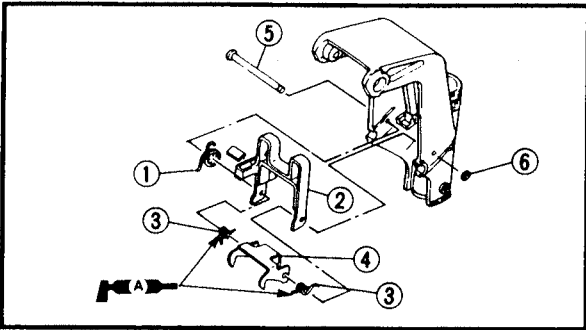
**2. Install:**

- Spring ①
- Tilt plate ② (outer)
- Spring ③
- Tilt plate ④ (inner)
- Pin ⑤
- Crip ⑥

**NOTE:**

Align the holes of the tilt plate (inner) and (outer), after installing the pin.

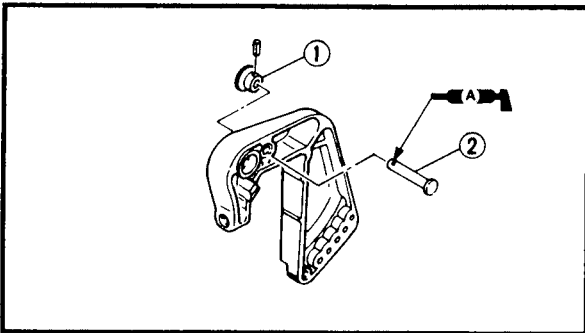
**3. Install:**

- Bushing ①
- Pin ②

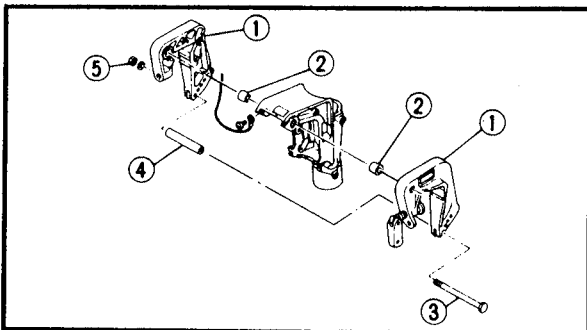
**4. Install:**

- Clamp bracket ①
- Friction piece ②
- Bolt ③
- Collar ④
- Nut ⑤

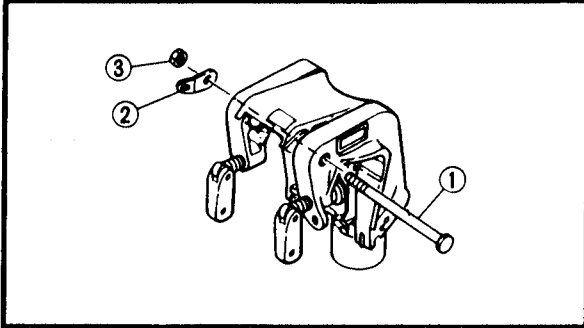

**5. Install:**

- Bolt ①
- Plate ②
- Nut ③



**Nut:**  
7 Nm (0.7 m · kg, 5.1 ft · lb)

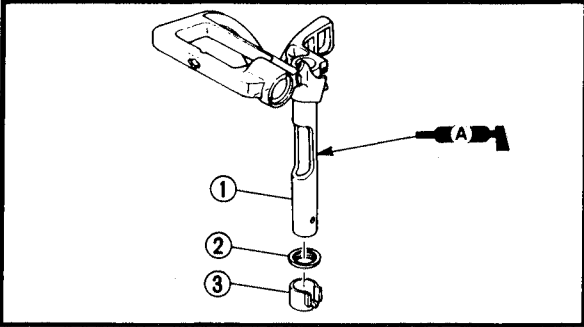

**6. Install:**

- Steering shaft ①
- Washer ②
- Bushing ③

**NOTE:** \_\_\_\_\_  
Apply water resistant grease to steering shaft.

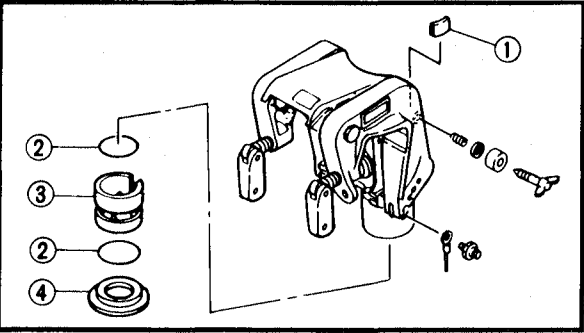

**7. Install:**

- Friction piece ①
- O-ring ②
- Bushing ③
- Bushing ④

**STEERING HANDLE  
PREPARATION FOR REMOVAL**

- Remove the carburetor.

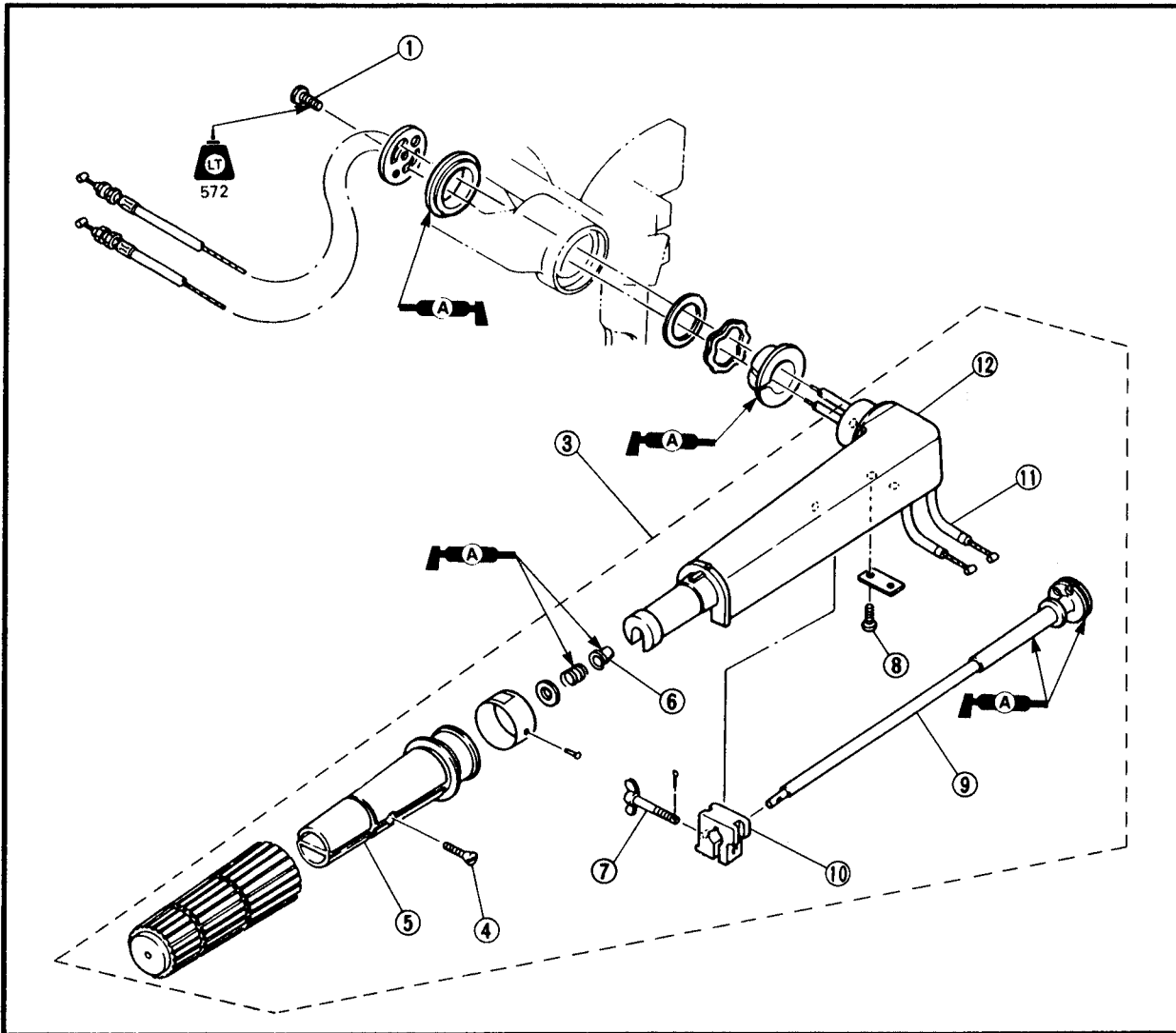

Extent of removal:    ① Steering handle removal            ② Steering handle disassembly

Extent of removal	Order	Part name	Q'ty	Remarks
<div style="display: flex; align-items: center;"> <div style="margin-right: 20px;"> <p>①</p> <p>↑</p> <p>↓</p> </div> <div style="margin-right: 20px;"> <p>②</p> <p>↑</p> <p>↓</p> </div> </div>	1	Bolt	1	
	2	Bushing	1	
	3	Steering handle assembly	1	
	4	Screw	1	
	5	Steering grip	1	
	6	Bushing	1	
	7	Screw	1	
	8	Screw	2	
	9	Throttle shaft	1	
	10	Friction piece	1	
	11	Throttle cable	2	
	12	Steering handle	1	

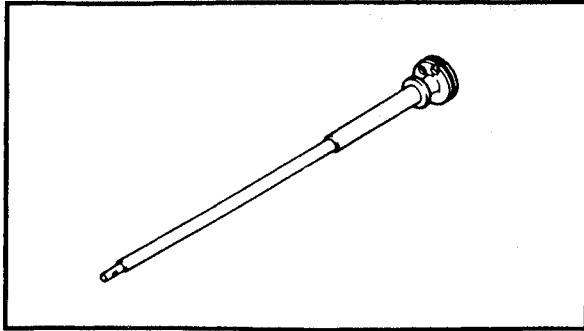

**INSPECTION**

**Throttle shaft**

1. Inspect:
- Throttle shaft  
Wear/Crack/Damage → Replace.

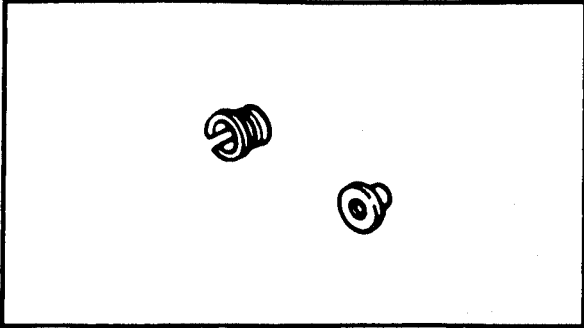

**Bushing**

1. Inspect:
- Bushing  
Wear/Crack/Damage → Replace.

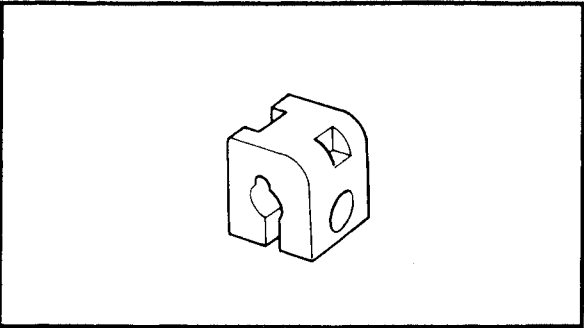

**Friction piece**

1. Inspect:
- Friction piece  
Wear/Crack/Damage → Replace.

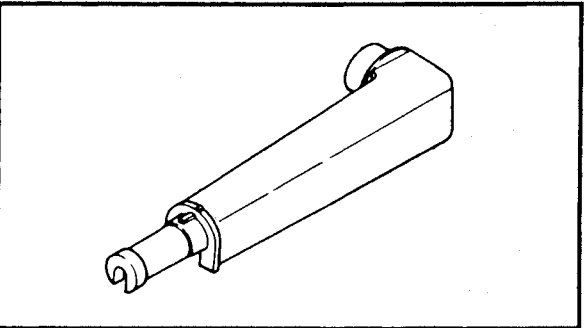

**Steering handle**

1. Inspect:
- Steering handle  
Wear/Crack/Damage → Replace.

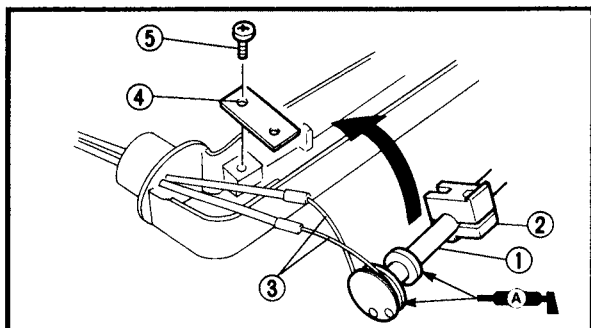

## ASSEMBLY AND INSTALLATION

### Steering handle

#### 1. Install:

- Throttle shaft ①
- Friction ②
- Throttle wire ③
- Plate ④
- Screw ⑤

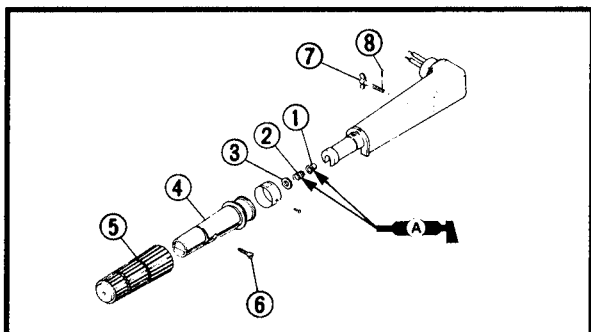

#### 2. Install:

- Bushing ①
- Spring ②
- Washer ③
- Steering grip ④
- Handle grip ⑤
- Screw ⑥
- Screw ⑦
- Pin ⑧

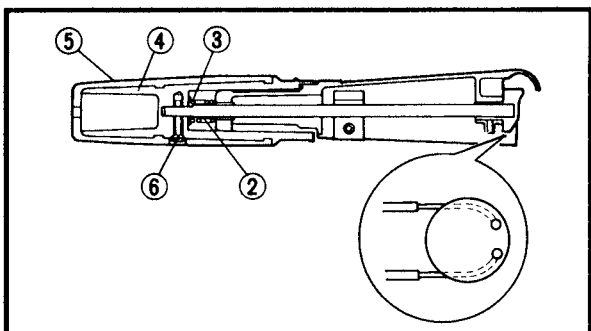

#### 3. Install:

- Bushing ①
- Steering handle assembly ②
- Plate ③
- Wave washer ④
- Bushing ⑤
- Cover ⑥
- Bolt ⑦

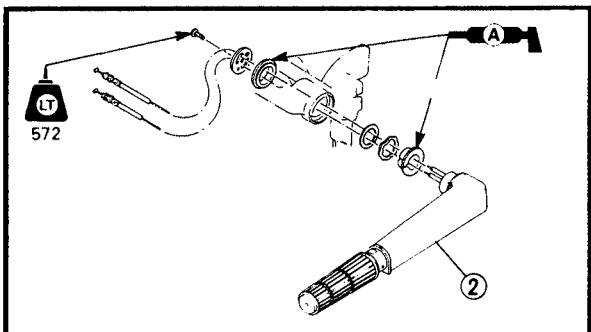

#### 4. Check:

- Steering handle operation
- Rough operation → Repair.

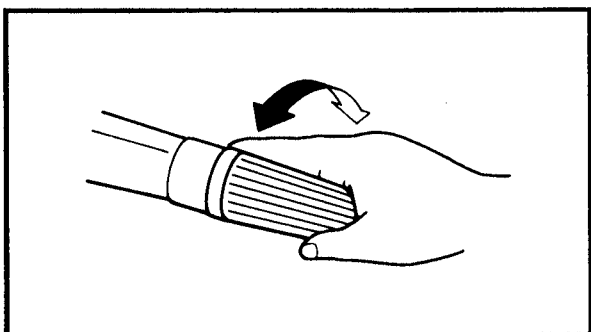

## CHAPTER 8

### ELECTRICAL SYSTEM

<b>ELECTRICAL COMPONENTS .....</b>	<b>8-1</b>
<b>WIRING DIAGRAM .....</b>	<b>8-3</b>
<b>INSPECTION.....</b>	<b>8-5</b>
<b>IGNITION SYSTEM .....</b>	<b>8-5</b>
Spark plug .....	8-5
Spark plug cap .....	8-5
Ignition coil .....	8-6
Engine stop switch .....	8-7
Stop switch .....	8-7
Ignition spark gap.....	8-8
Charge coil .....	8-9
Pulser coil.....	8-9
C.D.I. unit.....	8-9
C.D.I. system .....	8-10
<b>LIGHTING SYSTEM.....</b>	<b>8-14</b>
Lighting coil .....	8-14
Rectifier regulator.....	8-14
Rectifier .....	8-15
<b>ELECTRIC STARTING SYSTEM.....</b>	<b>8-15</b>
Fuse .....	8-15
Starter relay .....	8-15
Starter switch.....	8-16
Neutral switch.....	8-16
<b>STARTER MOTOR .....</b>	<b>8-17</b>
<b>PREPARATION FOR REMOVAL .....</b>	<b>8-17</b>
<b>REMOVAL POINTS.....</b>	<b>8-18</b>
Pinion.....	8-18
<b>INSPECTION .....</b>	<b>8-18</b>
Pinion.....	8-18
Brush .....	8-18
Brush holder .....	8-18
Armature .....	8-19
<b>ASSEMBLY .....</b>	<b>8-20</b>
<b>WIRING INSPECTION .....</b>	<b>8-21</b>
Wiring harness.....	8-21
Wiring connection .....	8-21



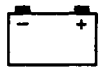

**ELECTRICAL COMPONENTS**

6CM	✓	6CEM	
8CM	✓	8CEM	

- ① C.D.I. magneto
- ② Rectifier regulator\*<sup>1</sup>
- ③ Stop switch\*<sup>2</sup>
- ④ Engine stop switch
- ⑤ 2P connector\*<sup>1</sup>
- ⑥ Ignition coil

- ⑦ C.D.I. unit
- ⑧ Charge coil
- ⑨ Pulser coil
- ⑩ Lighting coil
- \*<sup>1</sup> For Europe model only
- \*<sup>2</sup> It differs on specification.

A	4 Nm (0.4 m • kg, 2.9 ft • lb)
B	5 Nm (0.5 m • kg, 3.6 ft • lb)
C	7 Nm (0.7 m • kg, 5.1 ft • lb)

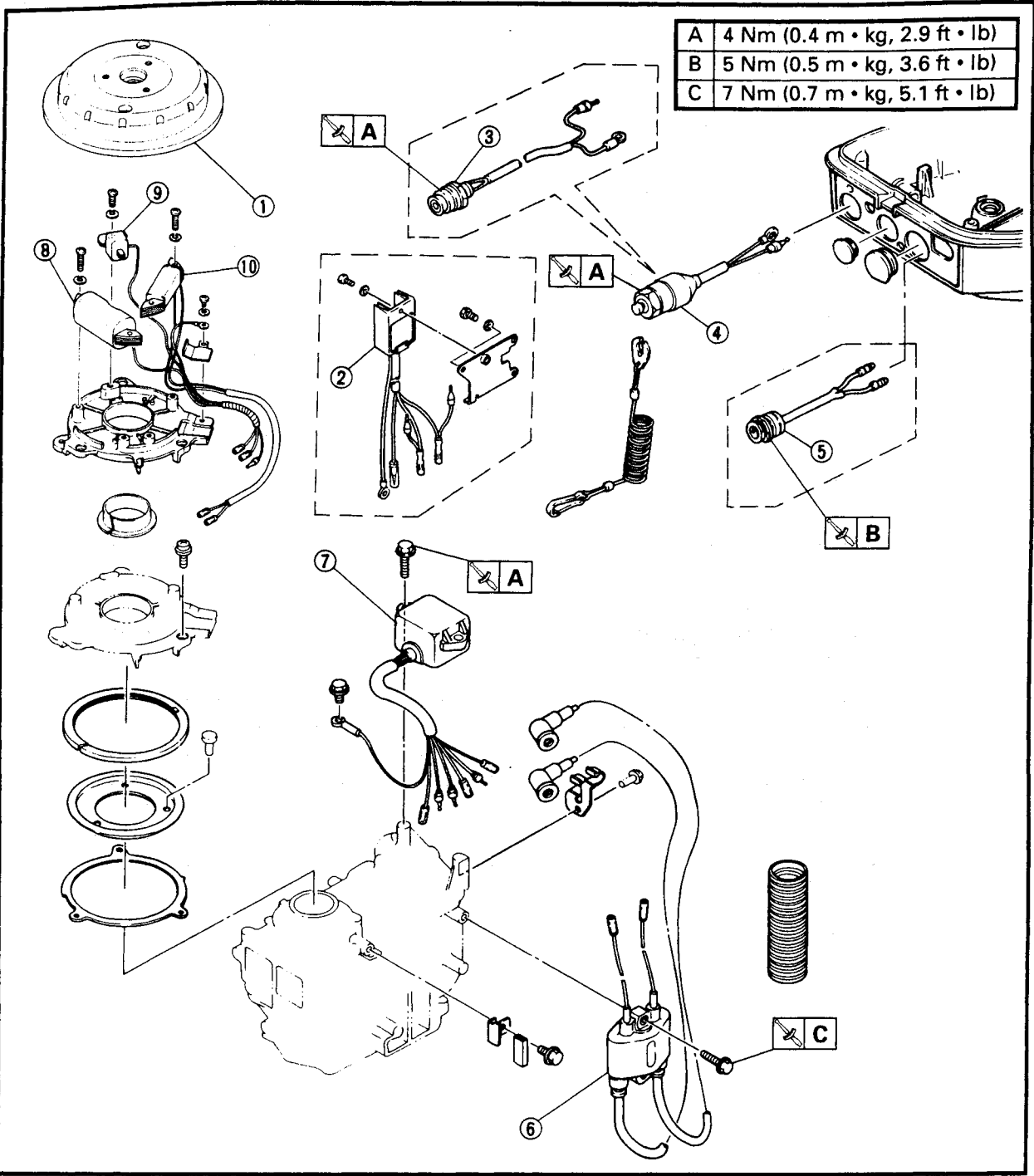

# ELEC

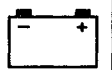

# ELECTRICAL COMPONENTS

6CM	6CEM	✓
8CM	8CEM	✓

- |                  |                      |                 |
|------------------|----------------------|-----------------|
| ① C.D.I. magneto | ⑥ Engine stop switch | ⑪ Charge coil   |
| ② Starting motor | ⑦ Starter switch     | ⑫ Pulsar coil   |
| ③ Starter relay  | ⑧ Ignition coil      | ⑬ Lighting coil |
| ④ Neutral switch | ⑨ C.D.I. unit        |                 |
| ⑤ Rectifier      | ⑩ Fuse               |                 |

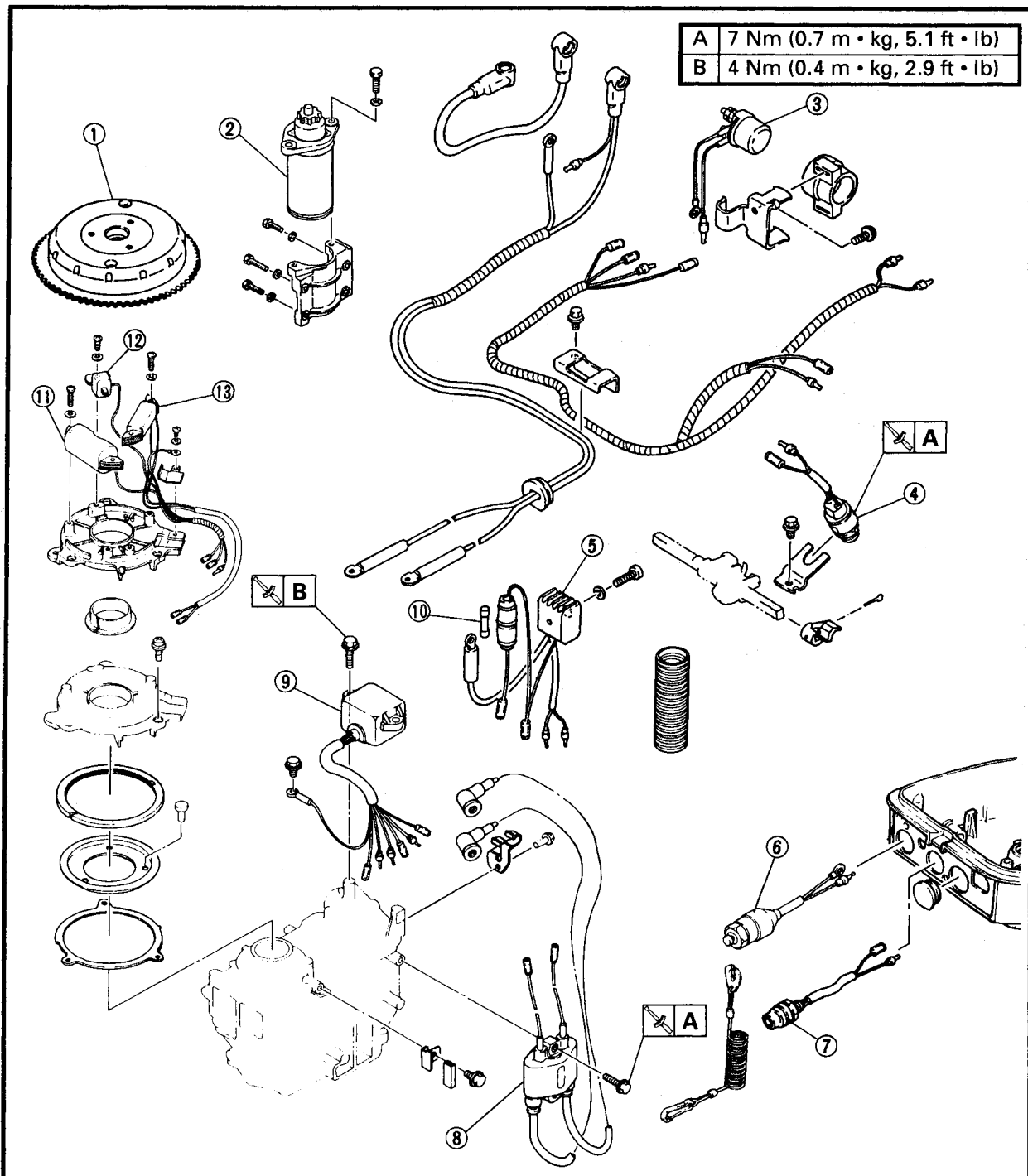



**WIRING DIAGRAM**

6CM	✓	6CEM	
8CM	✓	8CEM	

- ① C.D.I. unit
- ② Charge coil
- ③ Pulser coil
- ④ Lighting coil
- ⑤ Engine stop switch/  
Stop switch

- ⑥ 2P connector\*
- ⑦ Rectifier regulator\*
- ⑧ Ignition coil
- \* For Europe model

- B : Black
- Br : Brown
- G : Green
- G/W : Green/White
- O : Orange
- R : Red
- W : White
- W/R : White/Red

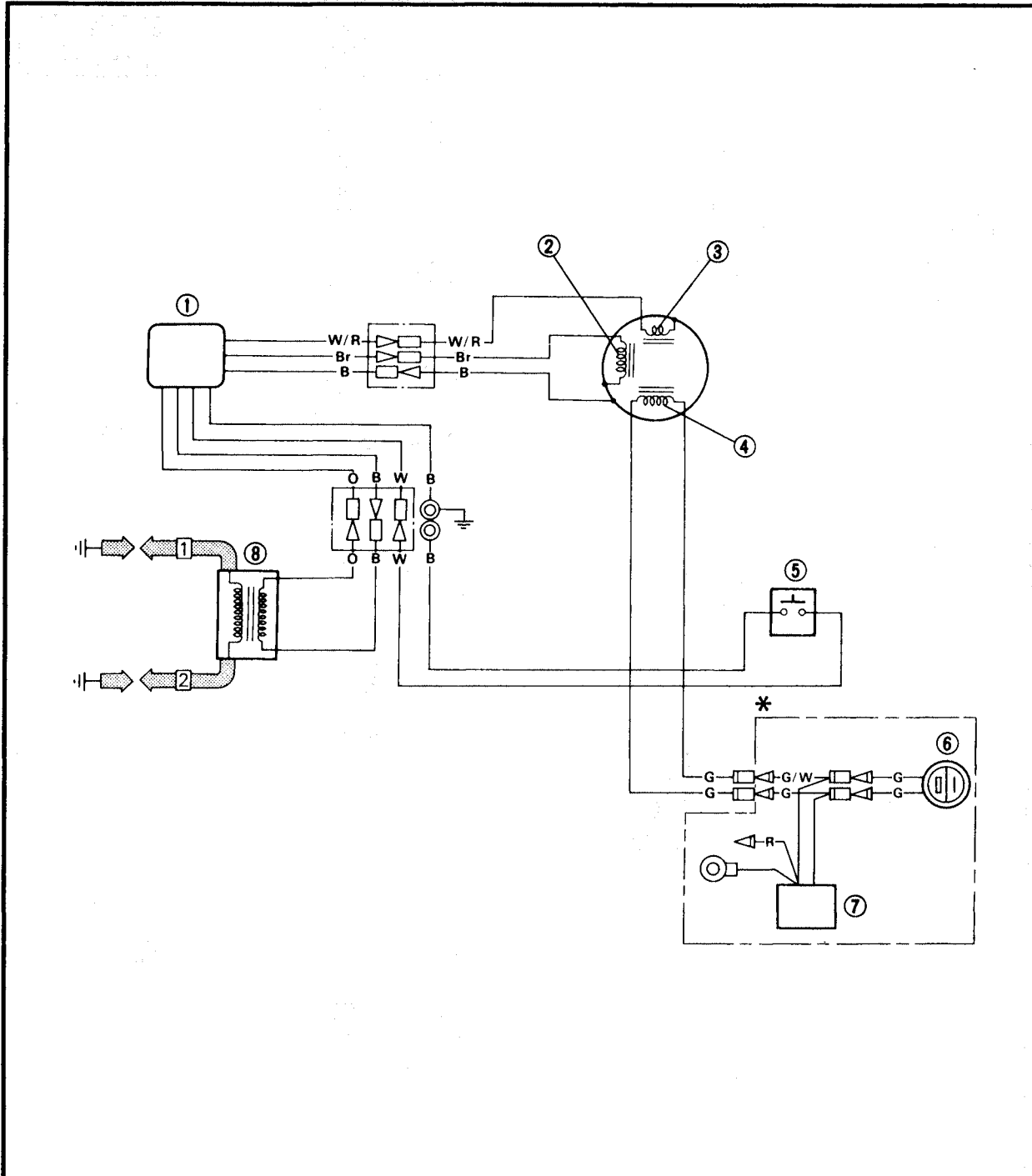

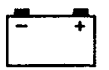

6CM	6CEM	✓
8CM	8CEM	✓

- ① C.D.I. unit
- ② Charge coil
- ③ Pulser coil
- ④ Lighting coil
- ⑤ Engine stop switch
- ⑥ Starter switch
- ⑦ Battery

- ⑧ Neutral switch
- ⑨ Starter motor
- ⑩ Starter relay
- ⑪ Fuse
- ⑫ Rectifier
- ⑬ Ignition coil

- B : Black
- Br : Brown
- G : Green
- G/W : Green/White
- O : Orange
- R : Red
- W : White
- W/R : White/Red

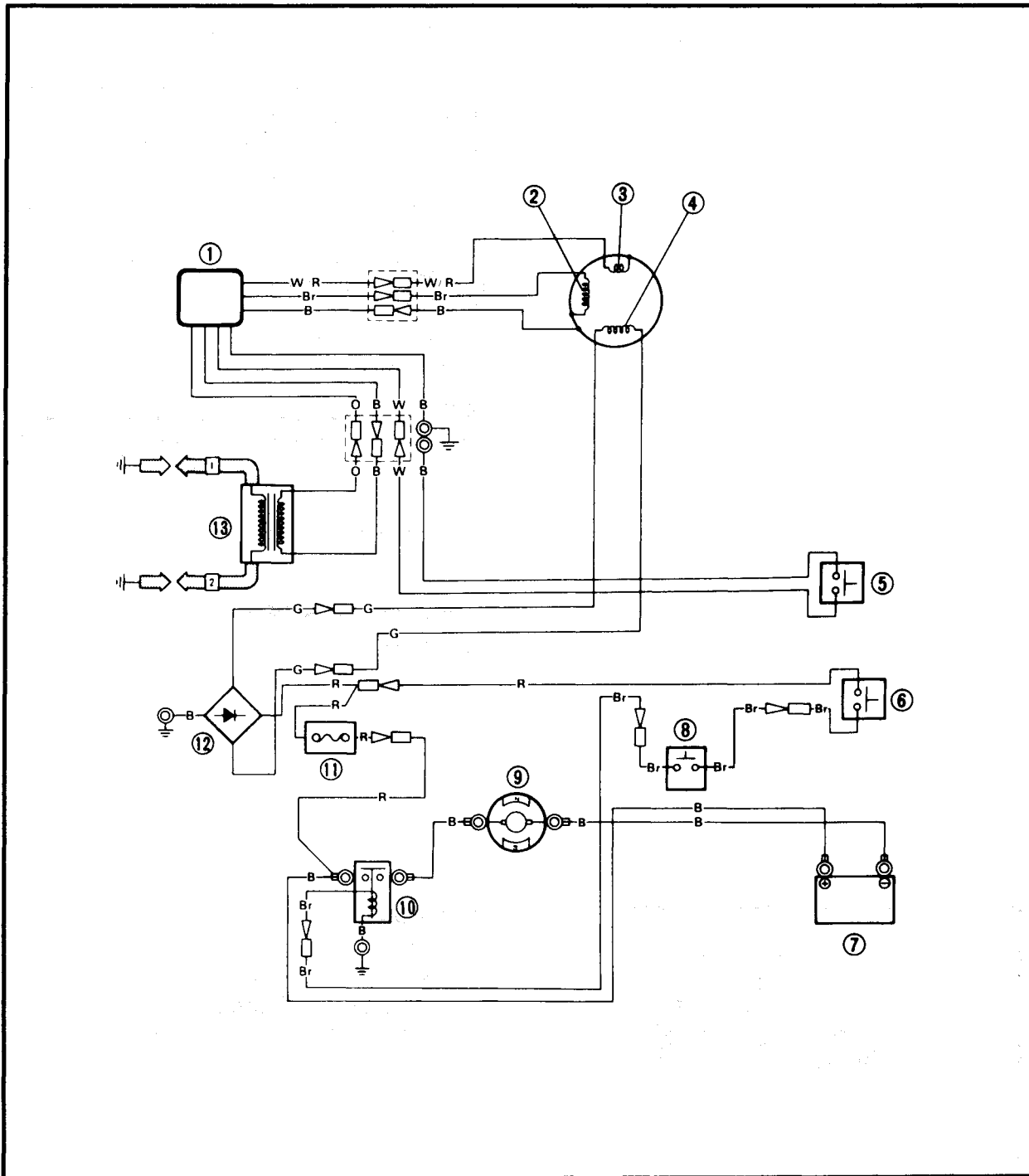

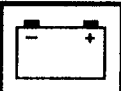

## INSPECTION

### CAUTION:

All measuring instruments should be handled with special care, or the correct measurement is impossible.

On an instrument powered by dry batteries, they should be checked for voltage periodically and replaced, if necessary.

### Low resistance measurement

When measuring the resistance of  $10\ \Omega$  or less using the digital tester, the correct measurement cannot be obtained because of the tester's internal resistance.

To obtain the correct value, subtract this internal resistance from the displayed measurement.



**Correct value =  
Displayed measurement – Internal resistance**

### NOTE:

The internal resistance of the tester can be obtained by connecting both of its terminals.

## IGNITION SYSTEM

### Spark plug

Refer to page 3-11.

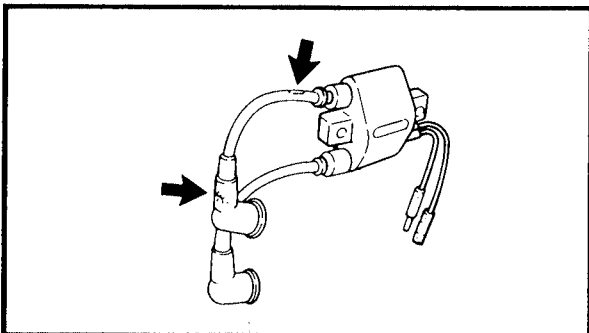

### Spark plug cap

#### 1. Inspect:

- Spark plug cap
- Loosen → Tighten.
- Crack/Damage → Replace.

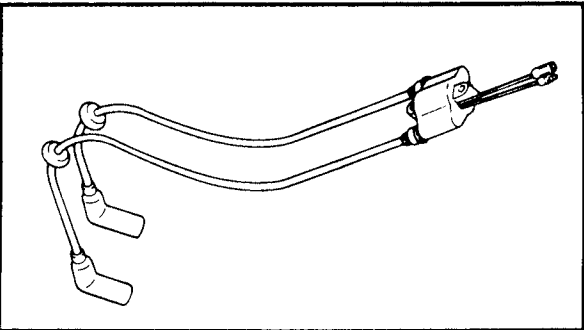
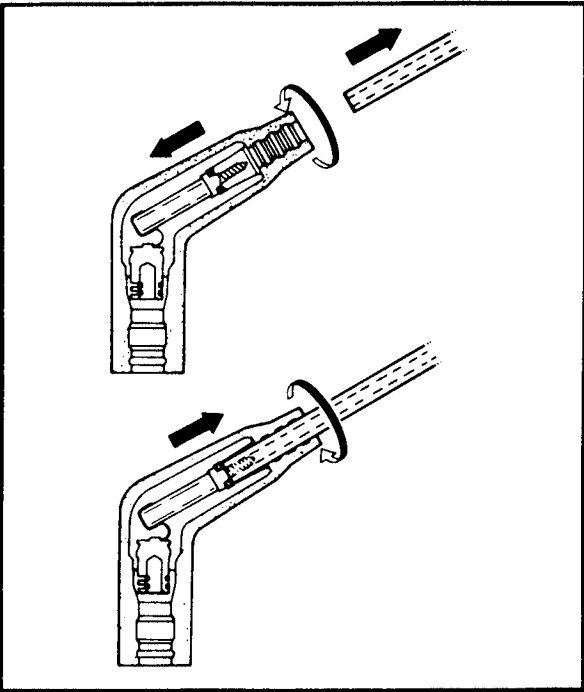
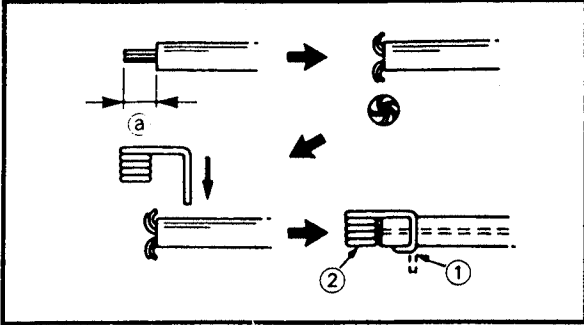
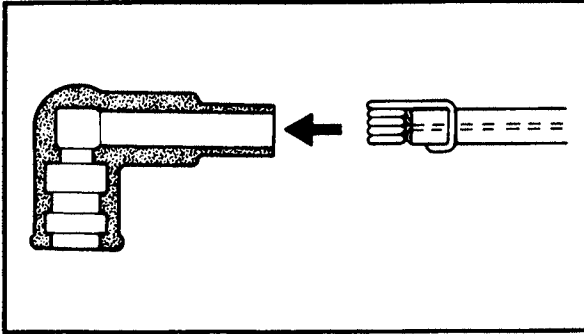

**Replacement steps:**  
(Except for Canada and Europe)

- Remove the spark-plug cap by pulling the cap, and remove the plug-cap spring from the high-tension cable.
- Cut about distance ① off the end of the high-tension cable.



**Distance ①:**  
5 mm (0.2 in)

- Referring to the diagram, strip about 5 mm (0.2 in) of the insulation off the end of the high-tension cable, and fit the plug cap spring.
- Push the cap spring into the plug cap.

- ① Bend
- ② Contact

**Replacement steps:**  
(For Canada and Europe)

- Remove the spark-plug cap by turning the cap counterclockwise.

**NOTE:** \_\_\_\_\_  
Avoid removing the plug cap by pulling the wire hard. Remove it by turning in and out.

- Install the plug cap by turning the cap clockwise until it stops.

**Ignition coil**

1. Inspect:

- High tension cord  
Crack/Damage → Replace.

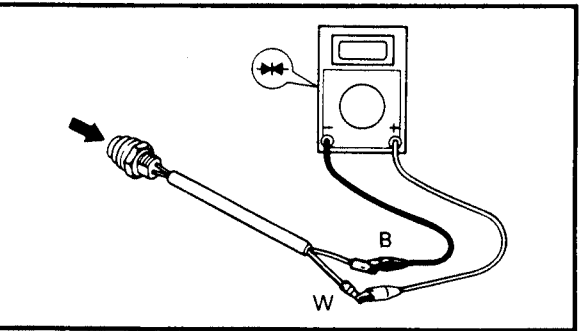
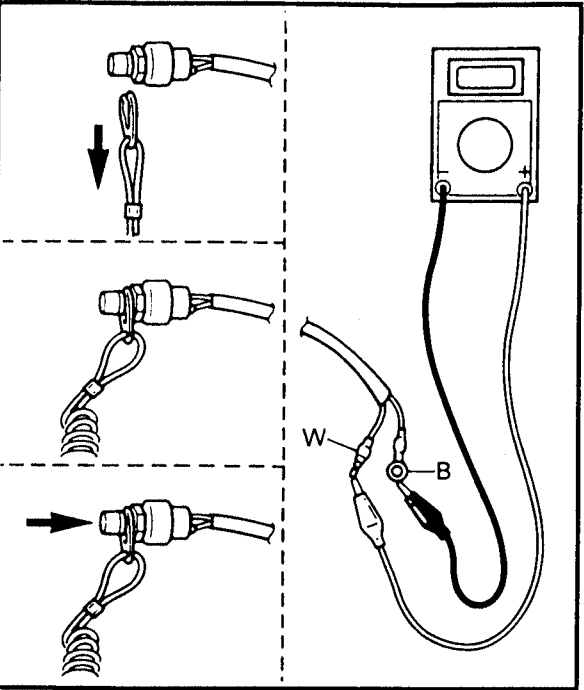
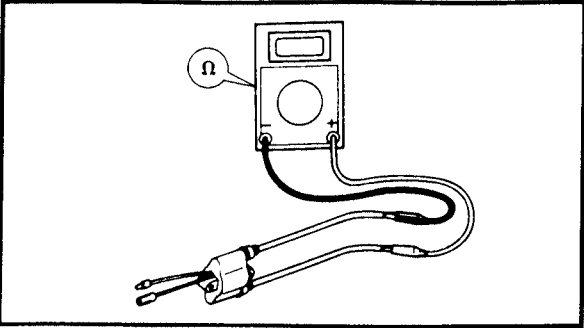
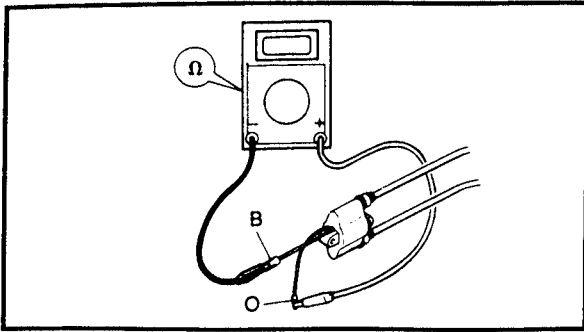

**2. Measure:**

- Primary coil resistance  
Out of specification → Replace.

	<b>Primary coil resistance:</b>
	<b>Orange (O) - Black (B)</b>
	<b>0.25 ~ 0.35 Ω at 20°C (68° F)</b>

**NOTE:**

When measuring the resistance of 10 Ω or less using the digital tester, the correct measurement cannot be obtained. Refer to "Lower resistance measurement".

**3. Measure:**

- Secondary coil resistance  
Out of specification → Replace.

	<b>Secondary coil resistance:</b>
	<b>High tension cord</b>
	<b>6.8 ~ 10.2 kΩ at 20° C (68° F)</b>

**Engine stop switch**

**1. Check:**

- Continuity  
Out of specification → Replace.

		<b>Color:</b> <b>White - Black</b>
	<b>Remove the lock-plate</b>	<b>Continuity</b>
	<b>Install the lock-plate</b>	<b>Discontinuity</b>
	<b>Push the button</b>	<b>Continuity</b>

**Stop switch**

**1. Inspect:**

- Continuity  
Out of specification → Replace.

		<b>Color:</b> <b>White - Black</b>
	<b>Free</b>	<b>Discontinuity</b>
	<b>Push the button</b>	<b>Continuity</b>

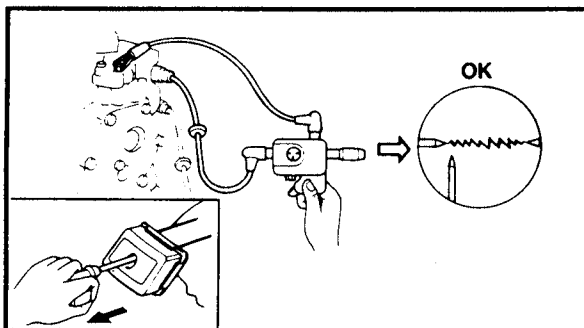
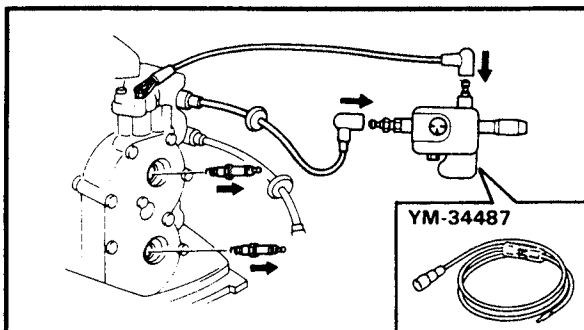
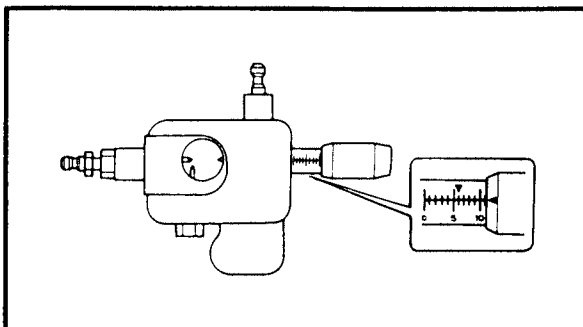
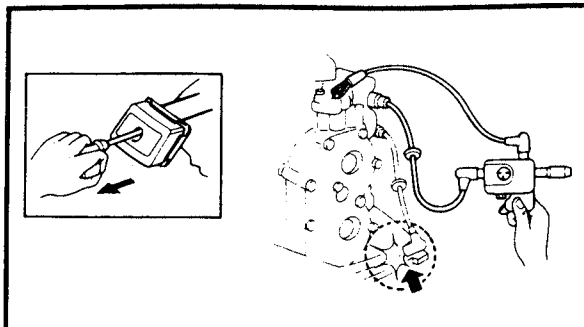
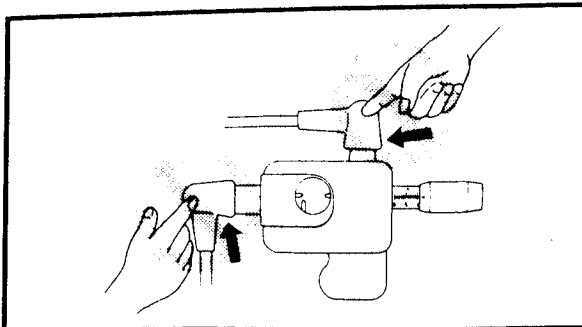
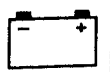

Ignition spark gap

**⚠ WARNING**

- While taking spark check be careful not to touch any connection of lead wires of the "Ignition spark gap tester".
- When doing the spark test, take special care not to allow leakage from the removed plug cap.
- This check is likely to produce sparks, so be sure that no flammable gas or fluid is in the vicinity.

1. Check:

- Ignition spark gap  
Out of specification → Replace.

**Checking steps:**

- Adjust the spark gap to the specified by turning the adjust knob.



**Spark gap tester:**  
YM-34487/90890-06754



**Spark gap:**  
9 mm (0.35 in)

- Connect the spark-plug cap to the spark gap tester.
- Remove the spark plugs from the engine.
- Cranking the engine and check sparks of ignition system seen through discharge window.



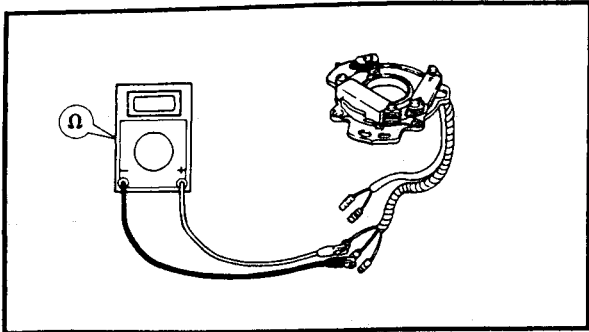

**Charge coil**

1. Measure:

- Charge coil resistance  
Out of specification → Replace.



**Charge coil resistance:**  
Brown (Br) - Black (B)  
81 ~ 99 Ω at 20° C (68° F)

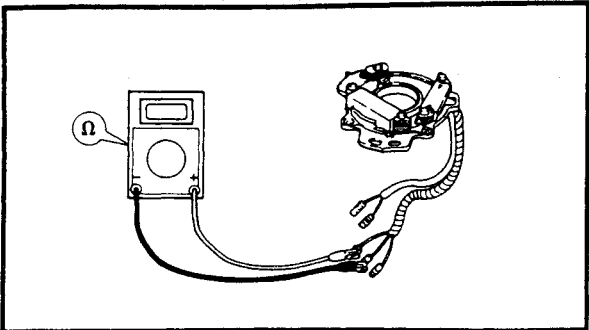

**Pulser coil**

1. Measure:

- Pulser coil resistance  
Out of specification → Replace.



**Pulser coil resistance:**  
White/Red (W/R) - Black (B)  
92 ~ 112 Ω at 20° C (68° F)

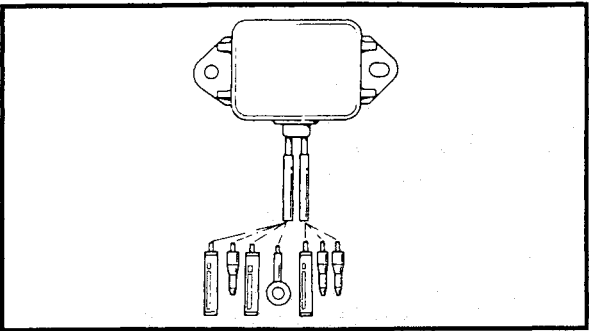

**C.D.I. unit**

1. Measure:

- C.D.I. unit resistance  
Out of specification → Replace.

**NOTE:**

- Digital tester can not be used for this inspection. Use analogue tester.
- C.D.I. resistance values will vary from meter to meter, especially with electronic digital meters. For some testers, polarity of leads is reversed.

- B : Black
- Br : Brown
- G : Green
- O : Orange
- W : White
- W/R : White/Red

Unit: KΩ

⊖	⊕	W	B	Br	W/R	O
W		∞	∞	∞	∞	∞
B		∞		7.5 ~ 11.3	∞	•
Br		∞	63.2 ~ 94.8		∞	•
W/R		8.8 ~ 13.2	14.4 ~ 21.6	30.4 ~ 45.6		•
O		∞	∞	∞	∞	

- : Needle swings once and returns to home position.
- ∞ : Discontinuity

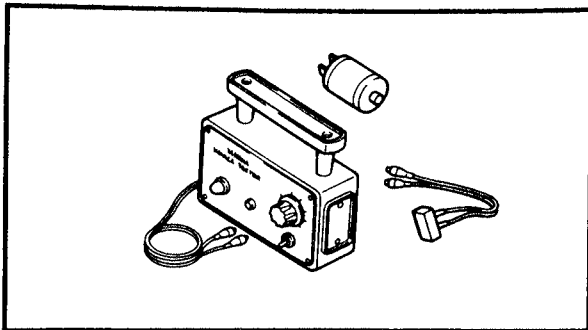
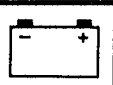

### C.D.I. system

#### NOTE:

- If there is no spark, or the spark is weak, continue with the C.D.I. test.
- If a good spark is obtained, the problem is not with the C.D.I. system, but possibly the spark plug or other component is defective.
- Use the following special tool in this inspection.



**C.D.I. tester:  
YU-91022-B**

- If lamp dose not light, check tester batteries. If they are installed correctly and are good, check the clip leads for faulty connections. If no fault can be found, refer to the warranty statement for instructions for sending the tester back to Electro-Specialities, inc.

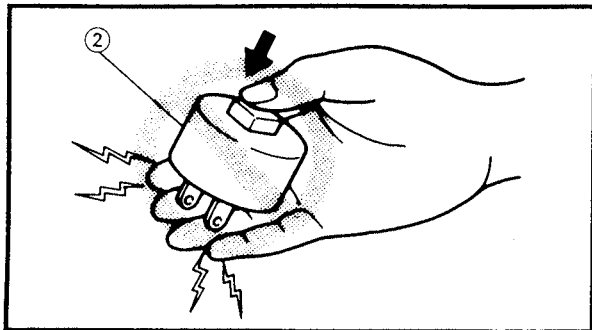
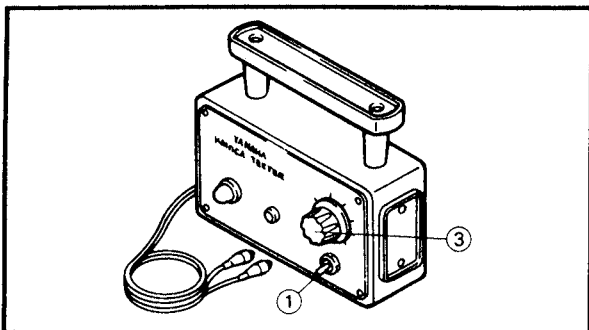

#### **⚠ WARNING**

While taking C.D.I. unit check be careful not to touch any connection of lead wires of the "C.D.I. tester".

#### 1. Check:

- C.D.I. tester for high scale
- No indication → Replace the tester.

#### Checking steps:

- Place switch ① in HIGH position.
- Plug the capacitive clip ② into an electric outlet. (117 VAC for ten seconds)

#### **⚠ WARNING**

Do not touch the plug pins on the capacitive clip while plugging it and depressing the button. An electric shock will result.

- Remove the capacitive clip from the outlet.
- Set the tester dial ③ to 50, or below.
- Connect the capacitive clip



**Yellow (Y) lead → Capacitive clip N terminal.**  
**Red (R) lead → Capacitive clip P terminal.**

- Depress the button on the capacitive clip.
- The indicator lamp on the tester should light

2. Check:

- C.D.I. tester for low scale
- No indication → Replace the tester.

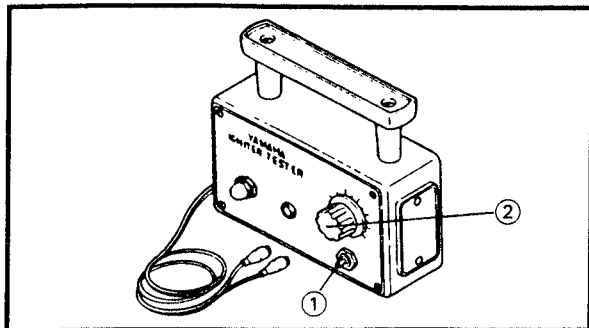

**Checking steps:**

- Place switch ① in LOW position.
- Set the tester dial ② to 50, or below.
- Connect the 12 V battery.

**Red (R) lead → Positive terminal.**  
**Yellow (Y) lead → Negative terminal.**

- The indicator lamp on the tester should light.

3. Check:

- C.D.I. unit output (test #1)
- No indication → Replace.

**Checking steps:**

- Disconnect the Black (B) and Orange (O) leads from the ignition coil.
- Remove the spark plugs.
- Connect the C.D.I. tester ① and load coil ② to C.D.I. unit ③ as shown.



**C.D.I. tester:**  
**YU-91022-1**  
**Load coil:**  
**YU-91022-3**

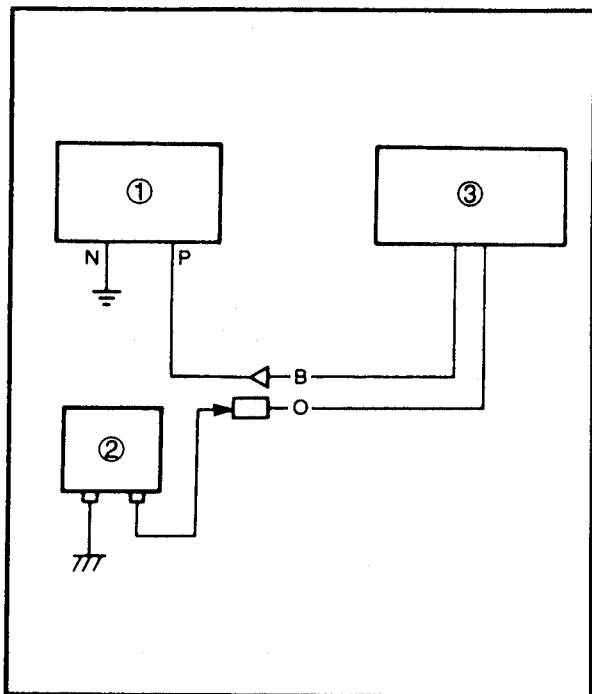

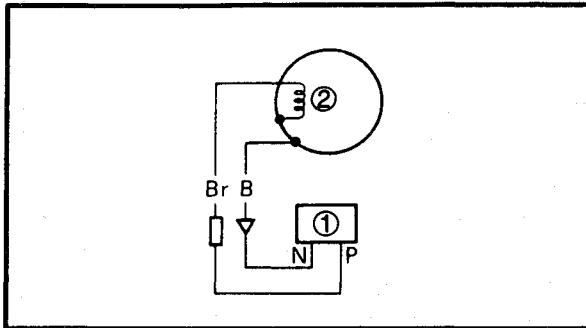

**NOTE:** \_\_\_\_\_  
 In this test, connect the load coil, provided along with the tester, between the C.D.I. unit output and the ground.

- Set the tester switch and dial to specified.

	<b>Range switch:</b>	<b>Dial setting:</b>
	H	75

- Cranking the engine.

**NOTE:** \_\_\_\_\_  
 ● The coil output varies greatly cranking speed.  
 ● Cranking the cold engine with the plugs in and a weak battery cannot be found proper readings.

4. Check:

- Charge coil output (test #2)  
 No indication → Replace.

**Checking steps:**  
 ● Disconnect the Brown (Br) and Black (B) leads from the charge coil.  
 ● Remove the spark plugs.  
 ● Connect the C.D.I. tester ① to charge coil ② as shown.

	<b>C.D.I. tester:</b> YU-91022-1
---	-------------------------------------

- Set the tester switch and dial to specified.

	<b>Range switch:</b>	<b>Dial setting:</b>
	H	80

- Cranking the engine.

**NOTE:** \_\_\_\_\_  
 ● The coil output varies greatly cranking speed.  
 ● Cranking the cold engine with the plugs in and a weak battery can not be found proper readings.

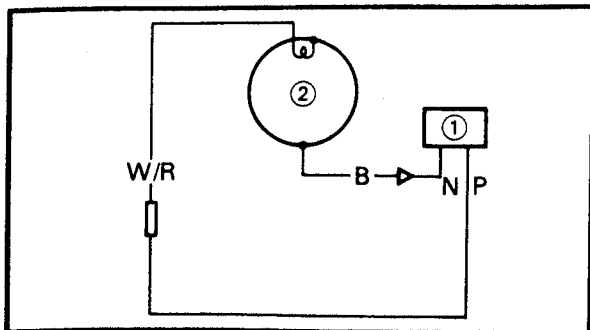
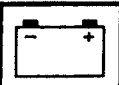

**5. Check:**

- Pulser coil output (test #3)
- No indication → Replace.

**Checking steps:**

- Disconnect the White/Red (W/R) and Black (B) leads from the pulser coil.
  - Remove the spark plugs.
- Connect the C.D.I. tester ① to pulser coil ② as shown.



**C.D.I. tester:**  
YU-91022-1

- Set the tester switch and dial to specified.



**Range switch:**

**Dial setting:**

**L**

**80**

- Cranking the engine.

**NOTE:** \_\_\_\_\_

- The coil output varies greatly cranking speed.
- Cranking the cold engine with the plugs in and a weak battery can not be found proper readings.

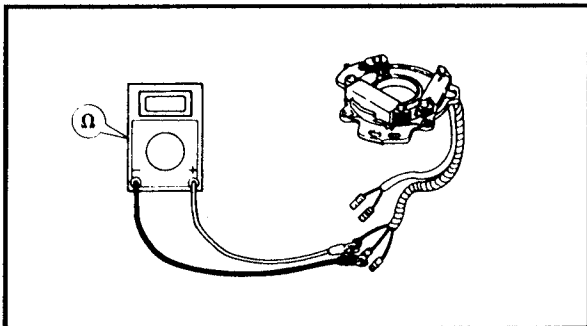
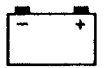

**LIGHTING SYSTEM**

**Lighting coil**

1. Measure:
  - Lighting coil resistance
 Out of specification → Replace.



**Lighting coil resistance:**  
**Green (G) - Green (G)**  
 0.36 ~ 0.44 Ω at 20 °C (68°F)

**NOTE:**

When measuring the resistance of 10 Ω or less using the digital tester, the correct measurement cannot be obtained. Refer to "Lower resistance measurement".

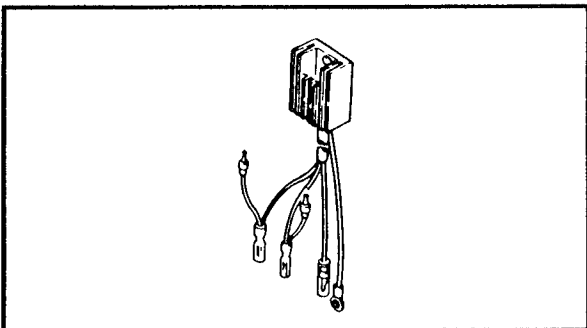

**Rectifier regulator**

6CM	✓	6CEM		(For Europe model)
8CM	✓	8CEM		

1. Check:
  - Continuity
 Out of specification → Replace.

**NOTE:**

Digital tester can not be used for this inspection. Use the analogue tester.

- B :Black
- G :Green
- G/W :Green/White
- R :Red

⊖	⊕	R	G	G/W	B
	R	∞	∞	∞	∞
	G	○	∞	∞	∞
	G/W	○	∞	∞	∞
	B	○	○	○	○

- : Continuity
- ∞ : Discontinuity

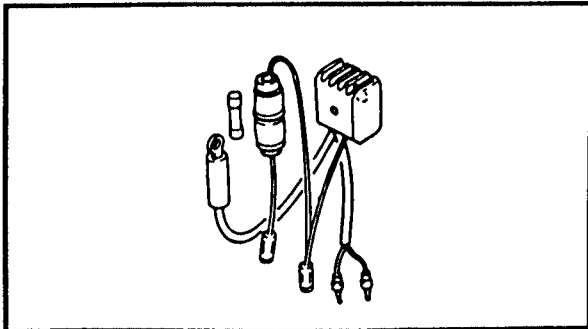

**Rectifier**

6CM	6CEM	✓
8CM	8CEM	✓

1. Check:

- Continuity  
Out of specification → Replace.

**NOTE:** \_\_\_\_\_  
Digital tester can not be used for this inspection. Use the analogue tester.  
\_\_\_\_\_

B :Black  
G1,2 :Green  
R :Red

⊖	⊕	R	G1	G2	B
	R		∞	∞	∞
	G1	○		∞	∞
	G2	○	∞		∞
	B	○	○	○	

○ : Continuity  
∞ : Discontinuity

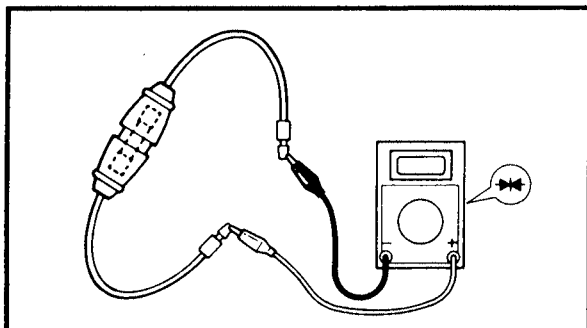

**ELECTRIC STARTING SYSTEM**

6CM	6CEM	✓
8CM	8CEM	✓

**Fuse**

1. Check:

- Fuse  
Blown → Replace.

	<b>Fuse rating:</b> 10 A
--	-----------------------------

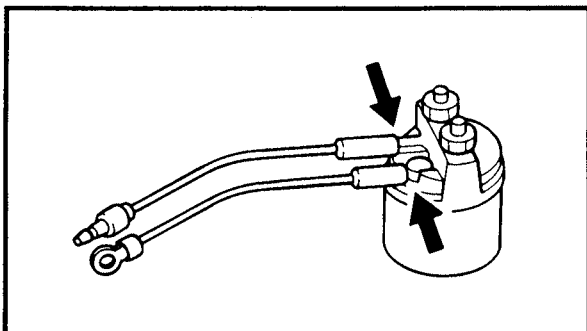

**Starter relay**

1. Inspect:

- Brown lead terminal
- Black lead terminal  
Loose → Tighten.

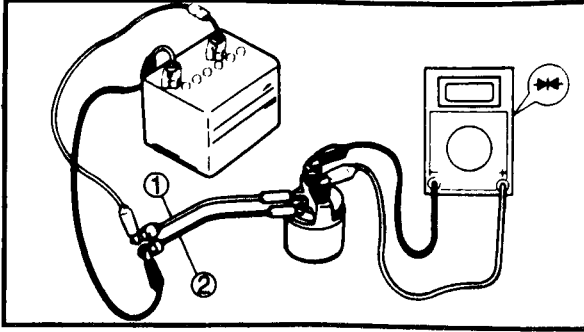

**2. Check:**

- Relay operation
- Does not function → Replace.

**Checking steps:**

- Connect a tester ( $\Omega \times 1$ ) between the terminals of the starter relay as shown.
- Connect a 12 V battery.

- ① **Brown lead** → **Positive terminal**
- ② **Black lead** → **Negative terminal**

- Check that there is continuity between the starter relay terminals.

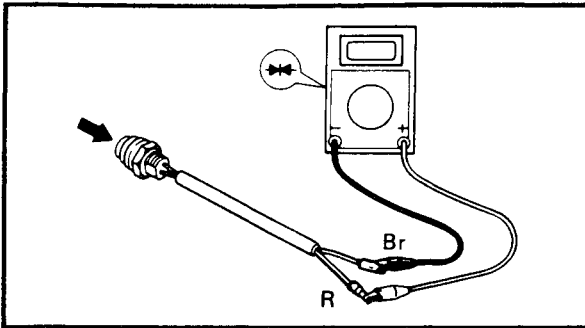

**Starter switch**

**1. Inspect:**

- Continuity
- Out of specification → Replace.

		<b>Color:</b> <b>Red - Brown</b>
	<b>Free</b>	<b>Discontinuity</b>
	<b>Push the button</b>	<b>Continuity</b>

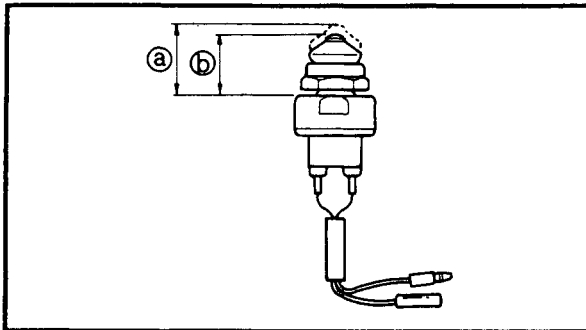

**Neutral switch**

**1. Inspect:**

- Continuity
- Out of specification → Replace.

	<b>Distance</b>	<b>Color:</b> <b>Brown - Brown</b>
<b>Free</b> ①	<b>19.6 ~ 20.5 mm</b> <b>(0.77 ~ 0.81 in)</b>	<b>Discontinuity</b>
<b>Push</b> ②	<b>18.5 ~ 19.5 mm</b> <b>(0.73 ~ 0.77 in)</b>	<b>Continuity</b>



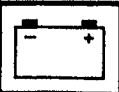

STARTER MOTOR

6CM	6CEM	✓
8CM	8CEM	✓

PREPARATION FOR REMOVAL

- Disconnect the battery cables.

**⚠ WARNING**

To avoid dangers of an electric shock, be sure to disconnect the battery cables from the battery before removing the starter motor.

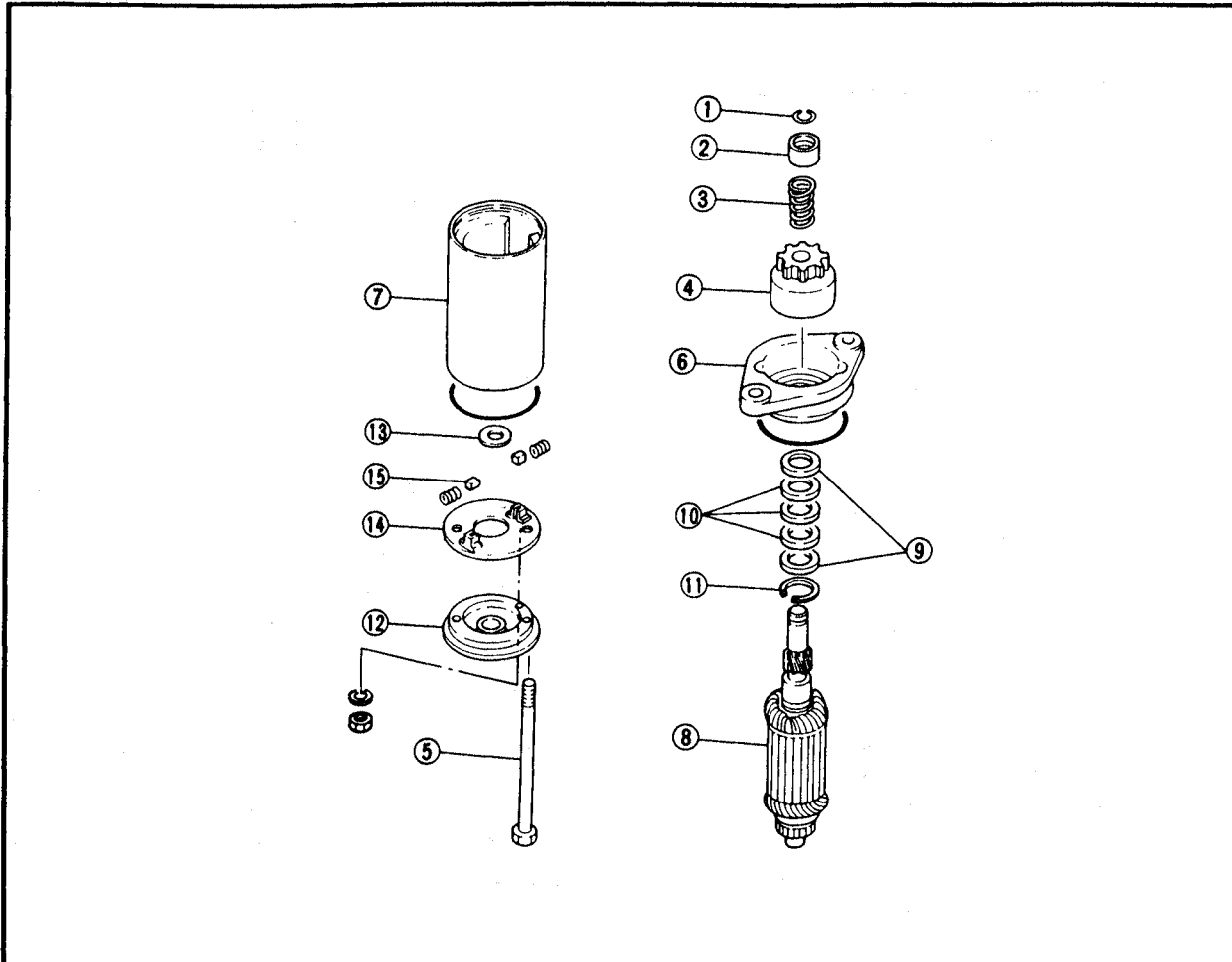

Extent of removal: ① Starter motor disassembly

Extent of removal	Order	Part name	Q'ty	Remarks
① 	1	Clip	1	Refer to "REMOVAL POINTS".
	2	Pinion stopper	1	
	3	Spring	1	
	4	Pinion	1	
	5	Through bolt	2	
	6	Front cover	1	
	7	Stator	1	
	8	Armature assembly	1	
	9	Washer	2	t=0.5 mm
	10	Washer	3	t=0.25 mm
	11	Ring	1	t=1.0 mm
	12	Rear cover	1	
	13	Washer	1	
	14	Brush holder	2	
	15	Brush	2	

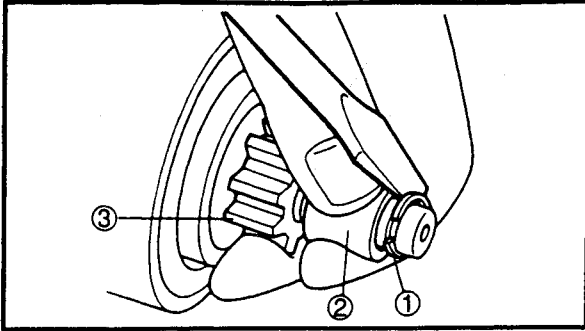
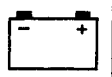

**REMOVAL POINTS**

**Pinion**

1. Remove:
  - Clip ①
  - Pinion stopper ②
  - Pinion ③

**NOTE:**

Using a screw-driver, pry off the clip.

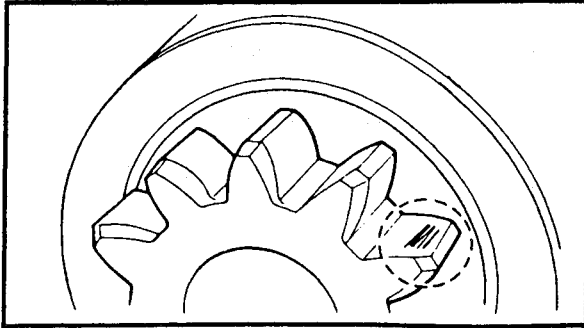

**INSPECTION**

**Pinion**

1. Inspect:
  - Pinion teeth  
Wear/Damage → Replace.

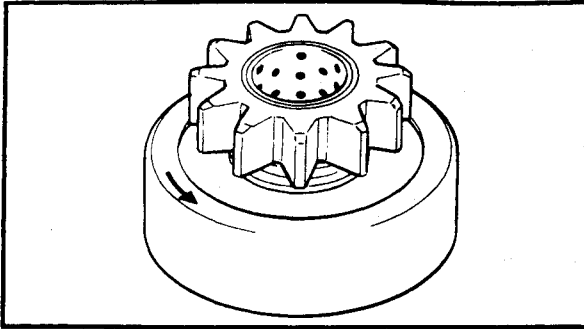

2. Check:

- Clutch movement  
Damage → Replace.

**NOTE:**

Rotate the pinion clockwise, and check that it freely. Also try to rotate the pinion counterclockwise and confirm that it locks.

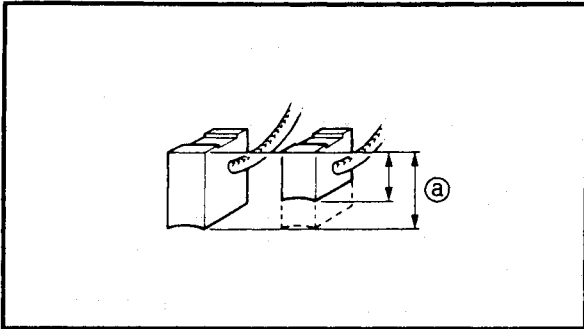

**Brush**

1. Measure:

- Brush length ①  
Out of specification → Replace brush holder assembly.

	<p><b>Brush length:</b> 4.5 ~ 7.5 mm (0.18 ~ 0.30 in)</p>
--	---

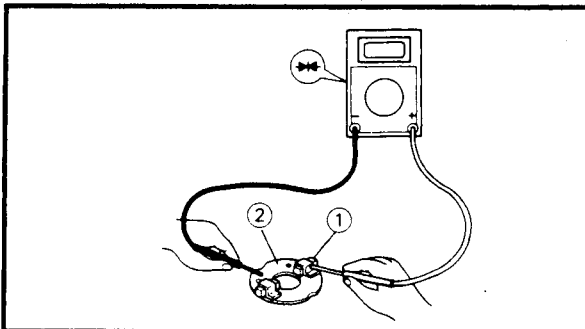

**Brush holder**

1. Check:

- Brush holder continuity  
Out of specification → Replace.

	<b>Brush holder continuity:</b>	
Positive brush holder - Earth ①	Discontinuity	
		②

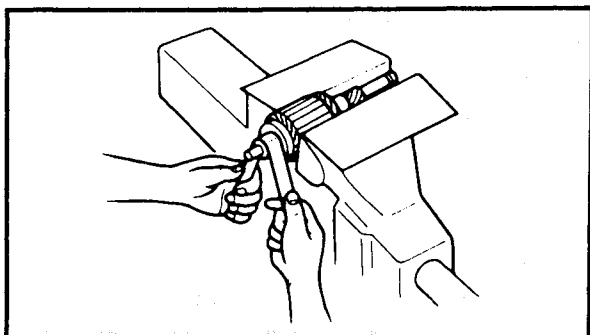

**Armature**

1. Inspect:

- Commutator surface  
Dirt/Burnt → Clean with #600 grit wet-or-dry sandpaper.

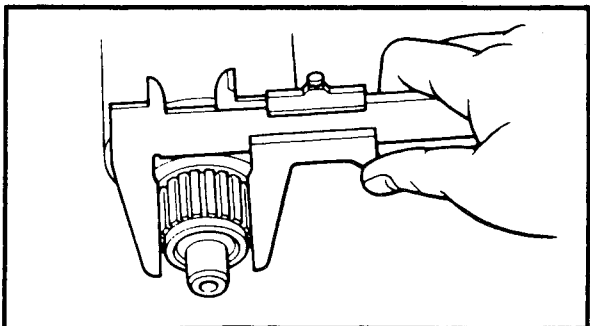

2. Measure:

- Commutator diameter  
Out of specification → Replace.

	<p><b>Commutator diameter:</b> 19.4 ~ 20.0 mm (0.76 ~ 0.79 in)</p>
--	--

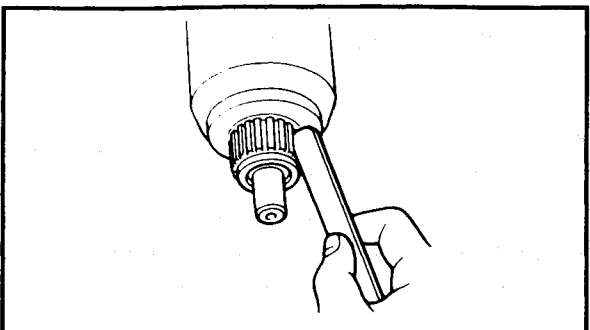

3. Check:

- Mica undercut  
Clog/Dirt → Clean.

**NOTE:**

Remove all particles of mica and metal by compressed air.

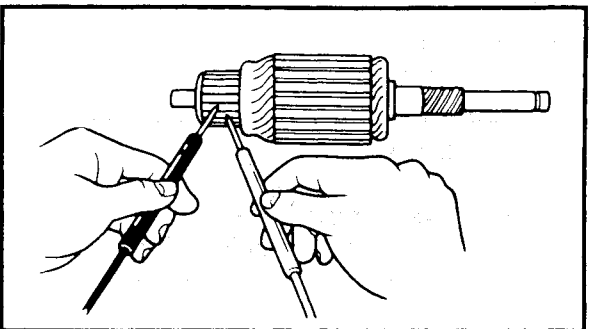

4. Check:

- Armature coil continuity  
Out of specification → Replace.

<b>Armature coil continuity:</b>	
<b>Commutator segments</b>	<b>Continuity</b>
<b>Segment - Laminations</b>	<b>Discontinuity</b>
<b>Segment - Shaft</b>	<b>Discontinuity</b>

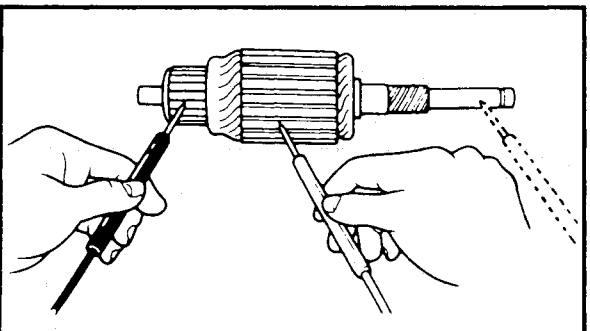

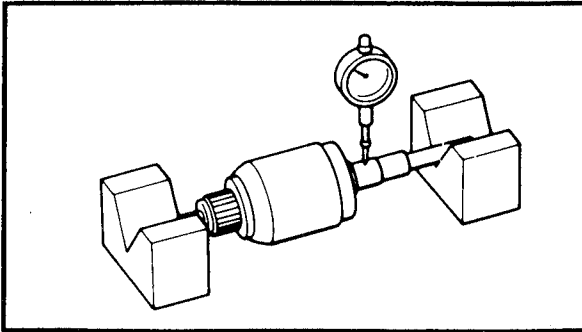

**5. Measure:**

- Commutator deflection
- Use a dial-gauge and block.
- Out of specification → Replace.



**Deflection limit:**  
0.05 mm (0.002 in)

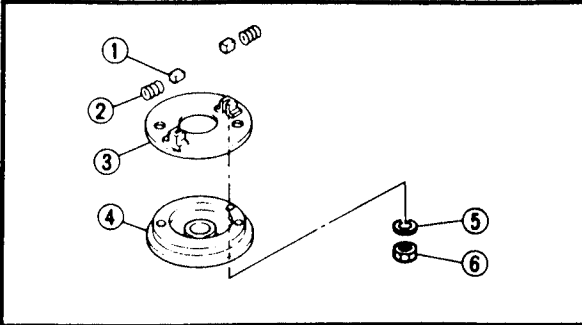

**ASSEMBLY**

**1. Install:**

- Brush ①
- Brush spring ②
- Brush holder ③
- Rear cover ④
- Washer ⑤ (spring)
- Nut ⑥

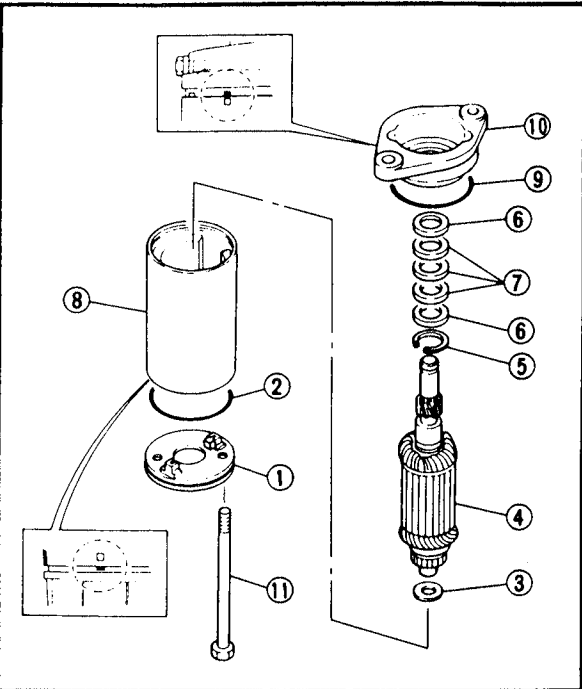

**2. Install:**

- Rear cover ①
- O-ring ②
- Washer (t=1.0 mm) ③
- Armature ④
- Ring ⑤
- Washer (t=0.5 mm) ⑥
- Washer (t=0.25 mm) ⑦
- Stator ⑧
- O-ring ⑨
- Front cover ⑩
- Through bolt ⑪

**NOTE:**

Align the cut in the cover with the projection on the stator.

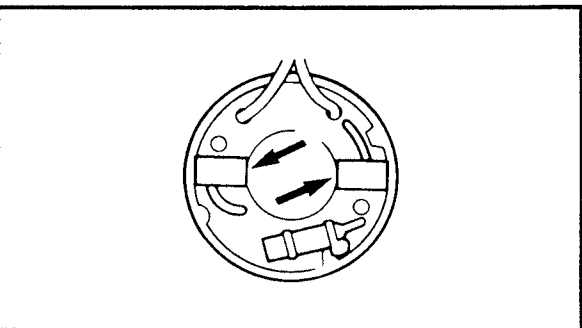

**CAUTION:**

Do not scratch the brushes when installing the armature on the rear cover.

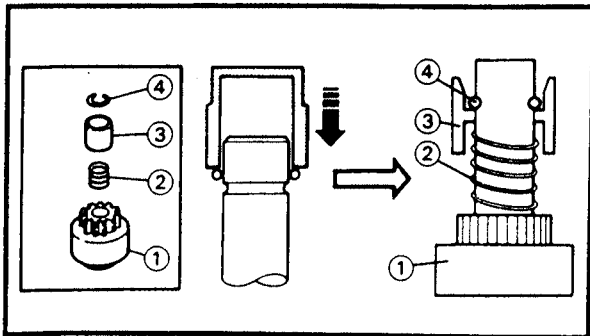

## 3. Install:

- Pinion ①
- Spring ②
- Pinion stopper ③
- Clip ④

**NOTE:**

Make sure the clip tightly fits in the pinion stopper.

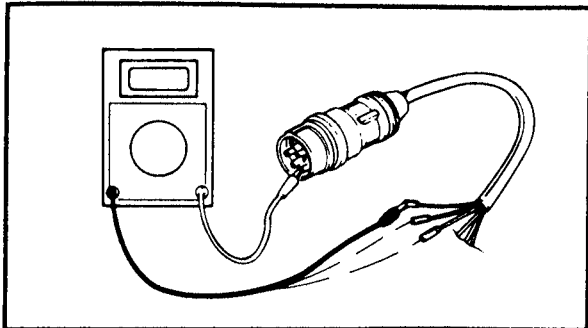
**WIRING INSPECTION****Wiring harness**

## 1. Check:

- Continuity
- Out of specification → Replace.

**Checking steps:**

- Check the continuity between the terminal side and each connector. Cores and pins of identical colors must be connected or a continuity test can not be made.
- If any of the cores are open-circuit, replace the wiring harness.

**Wiring connection**

## 1. Check:

- Wiring connection
- Poor connection → Correct.

---

**CHAPTER 9**  
**TROUBLESHOOTING**

**ENGINE AND RELATED PARTS**..... 9-1  
ENGINE DOES NOT START/ENGINE TURNS OVER BUT STALLS/  
ENGINE RUNS IRREGULARLY, STOPS OR IDLES ROUGHLY..... 9-1  
POWER LOSS ..... 9-3  
ENGINE MISFIRES ..... 9-6

**GEAR SHIFTING**..... 9-8  
GEAR SHIFTING IS IMPOSSIBLE..... 9-8

**ELECTRICAL SYSTEM (ELECTRIC STARTER MODEL)** ..... 9-9  
BATTERY IS NOT CHARGED..... 9-9

**ENGINE AND RELATED PARTS**

**ENGINE DOES NOT START/ENGINE TURNS OVER BUT STALLS/  
ENGINE RUNS IRREGULARLY, STOPS OR IDLES ROUGHLY**

Check:

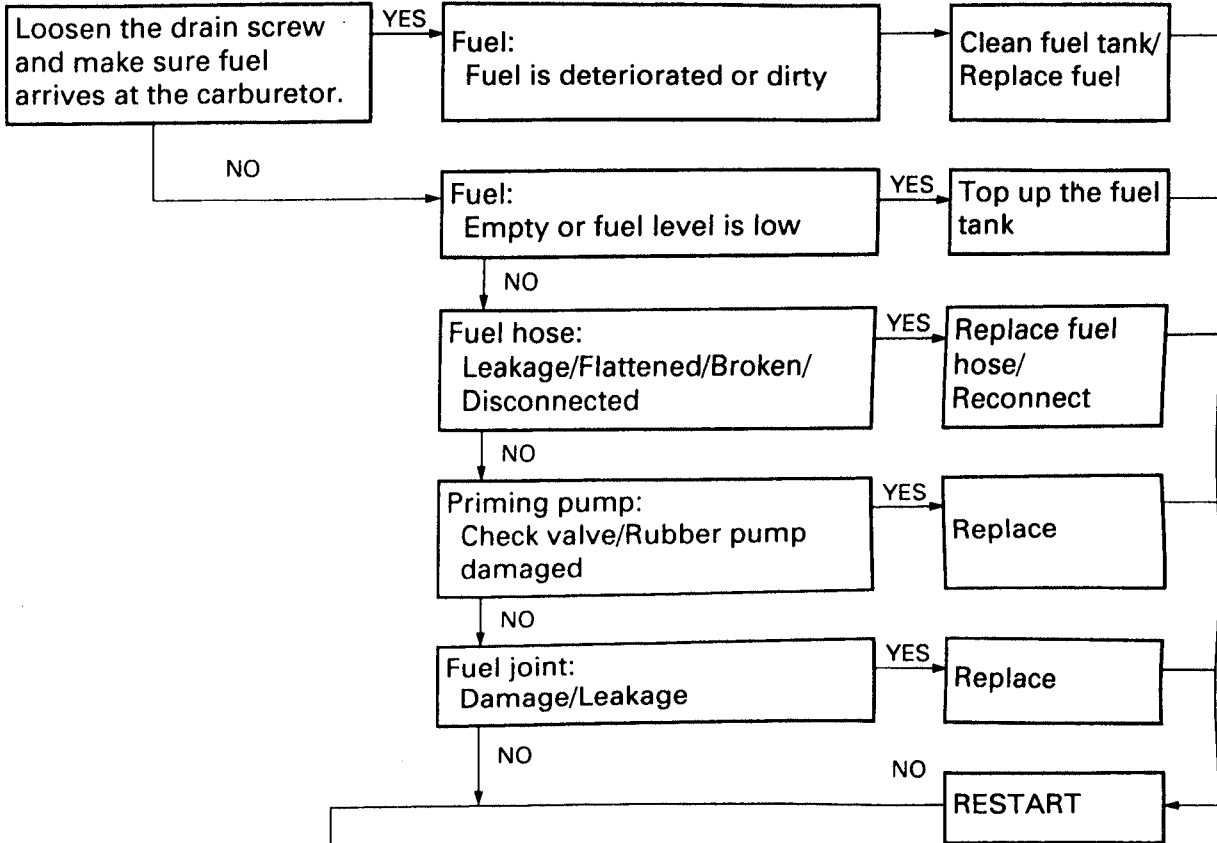

Check:

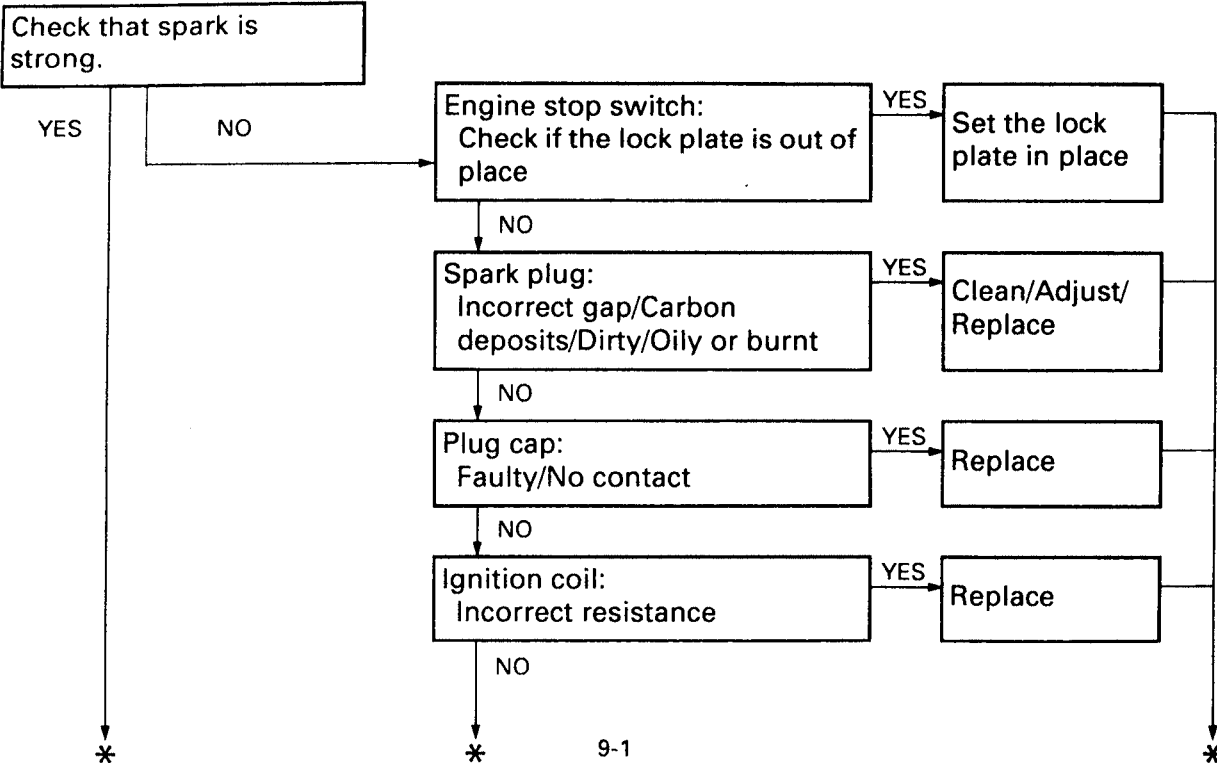

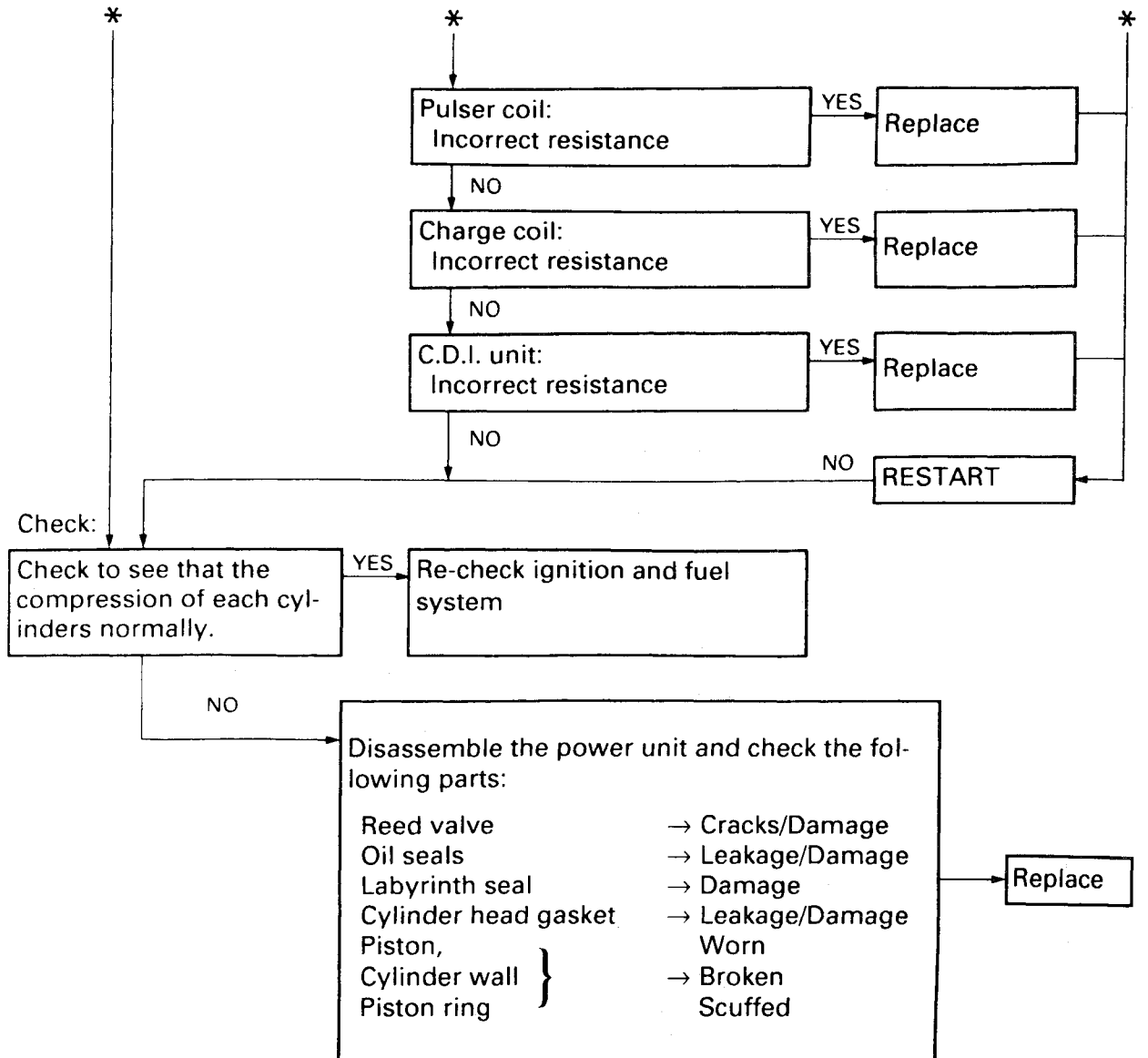



**POWER LOSS**

Check:

Boat is loaded properly.

YES

NO

Check the distribution of the load on the boat:  
Improper load distribution,  
Overload

YES

Propeller load distribution

NO

Boat hull:  
Fouled with seaweeds and shells

YES

Clean boat hull

NO

Trim angle:  
Improper

YES

Adjust

NO

Transom height:  
Too lower or higher/Air draw/  
Cavitation

YES

Adjust

NO

NO

CRUISING

Check:

Irregularities of the lower unit.

NO

YES

Propeller selection:  
Make sure the engine runs at  
4,500 ~ 5,500 rpm with wide-  
open throttle

NO

Reselection

YES

Propeller:  
Bent/Broken/Loosely fit

YES

Replace

NO

Water inlet:  
Clogged

YES

Clean

NO

Water pump:  
Worn/Broken

YES

Replace

NO

NO

CRUISING

\*

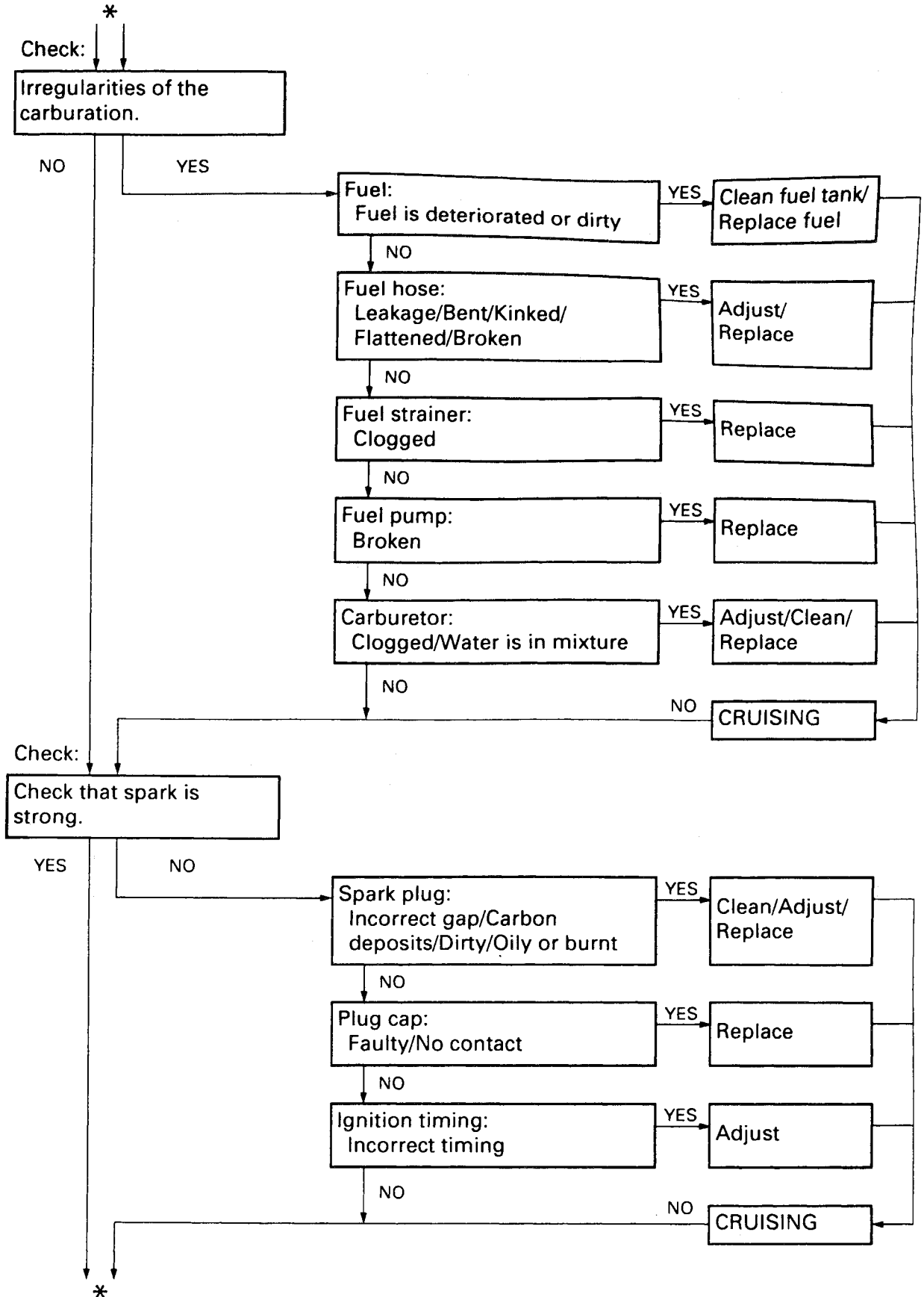

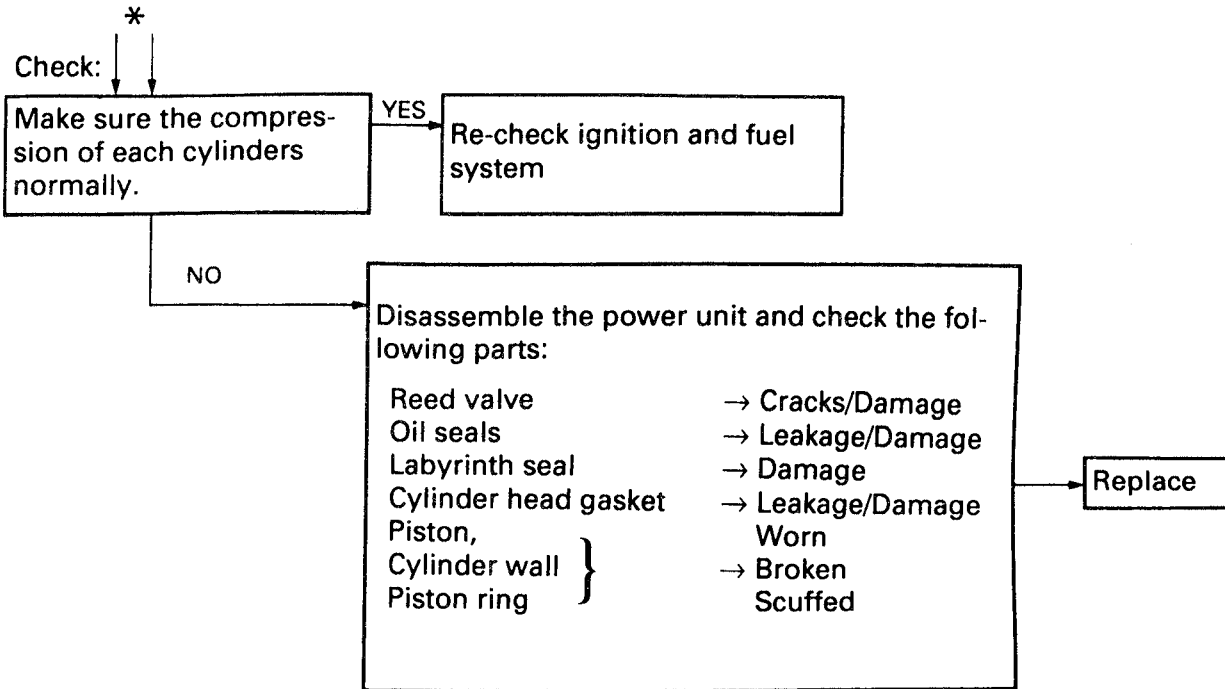

**ENGINE MISFIRES**

[First check for spark to find cause.]

Check:

Irregularities of the carburation.

NO

YES

Fuel:  
Fuel is deteriorated or dirty

YES

Clean fuel tank/  
Replace fuel

NO

Fuel strainer:  
Clogged

YES

Replace

NO

Carburetor:  
Clogged

YES

Clean

NO

NO

RESTART

Check:

Check that spark is strong.

YES

NO

Spark plug:  
Incorrect gap/Carbon deposits/Dirty/Oily or burned

YES

Clean/Adjust/  
Replace

NO

Plug cap:  
Broken or not tightly fitted

YES

Replace

NO

Ignition coil:  
Defective, check resistance  
→ out of specification

YES

Replace

NO

Pulser coil:  
Incorrect resistance

YES

Replace

NO

Charge coil:  
Incorrect resistance

YES

Replace

NO

Ignition timing:  
Incorrect timing

YES

Adjust

NO

\*

\*

\*

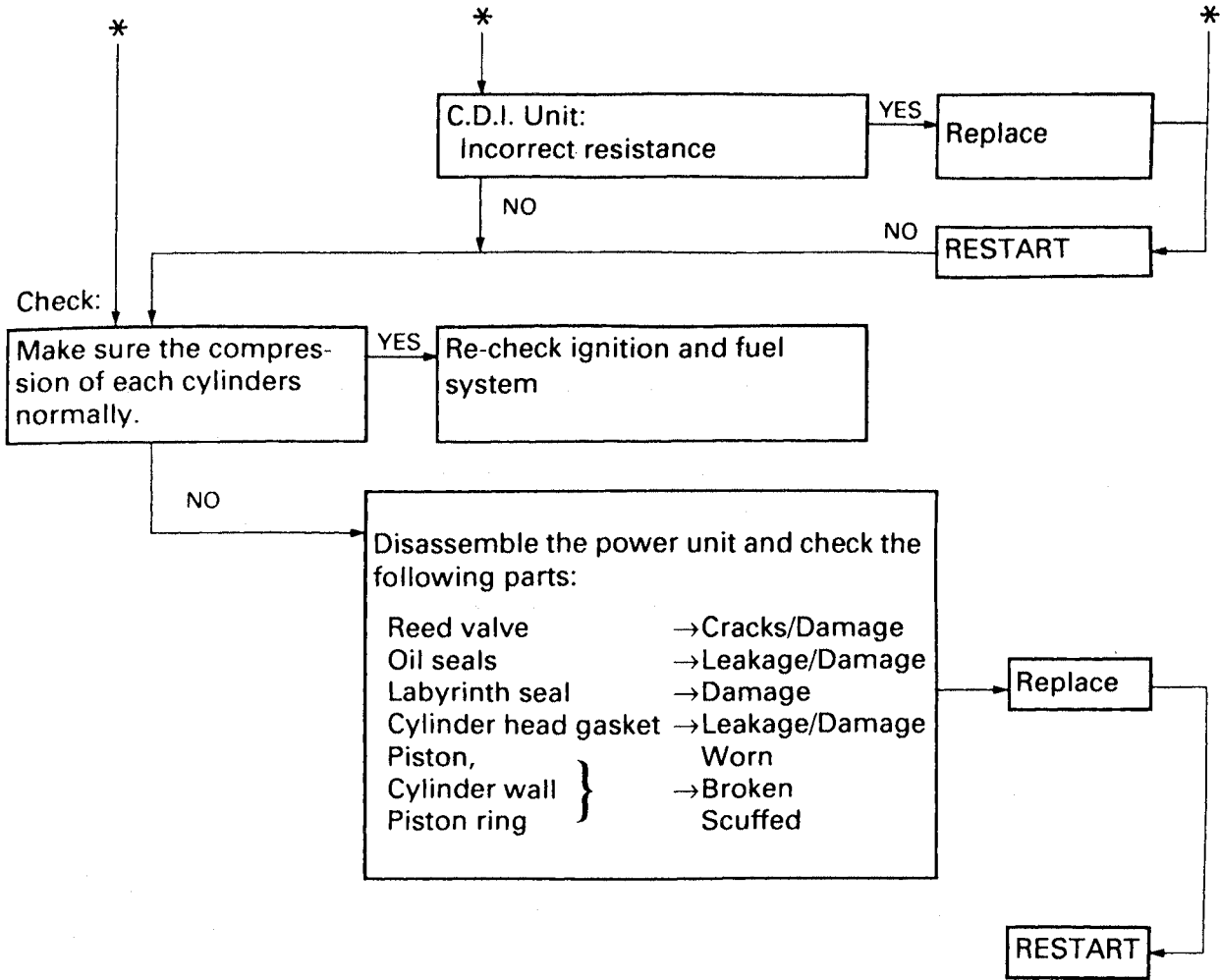

**GEAR SHIFTING  
GEAR SHIFTING IS IMPOSSIBLE**

**⚠ WARNING**

**Do not start engine during this inspection.**

**Manual handle model**

Move shift handle to "Neutral", "Forward" and "Reverse".  
Turn propeller and check that gears are in "Neutral", "Forward" and "Reverse".

Check:

Irregularities of the shifting system.

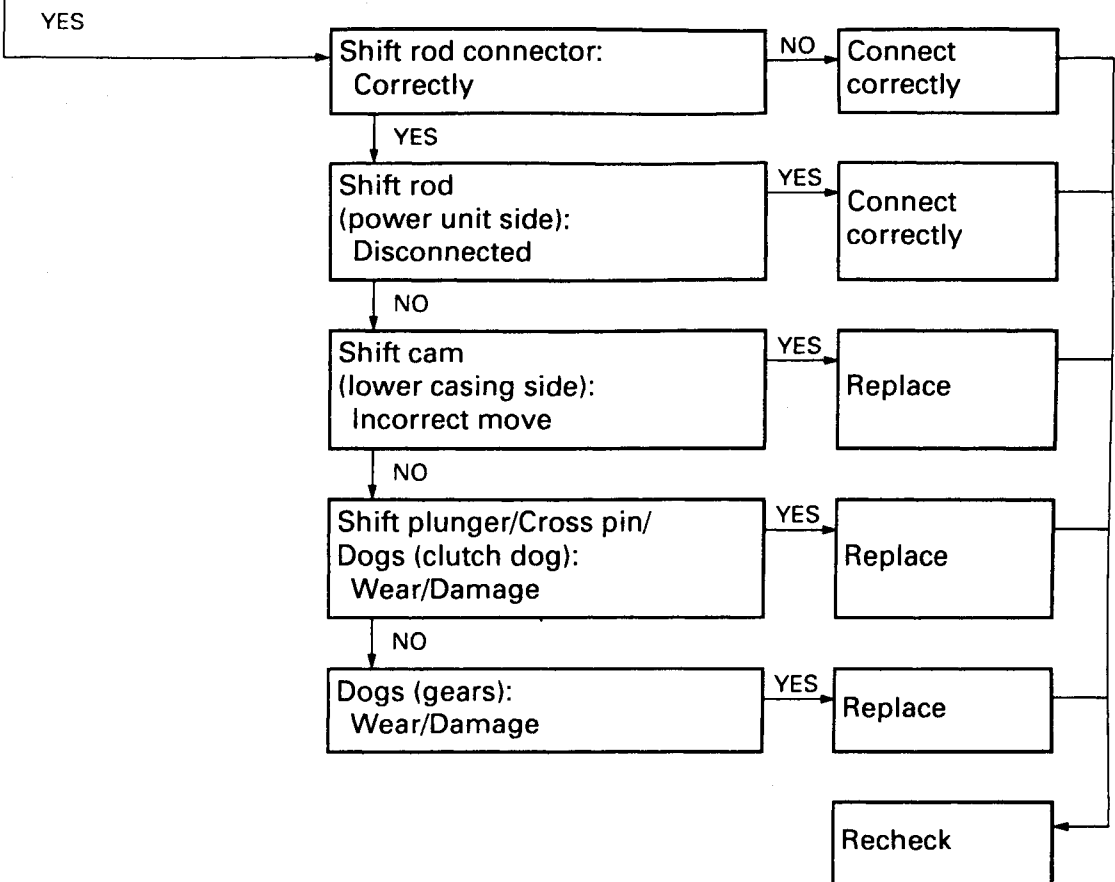

ELECTRICAL SYSTEM (ELECTRIC STARTER MODEL)

BATTERY IS NOT CHARGED

Check:

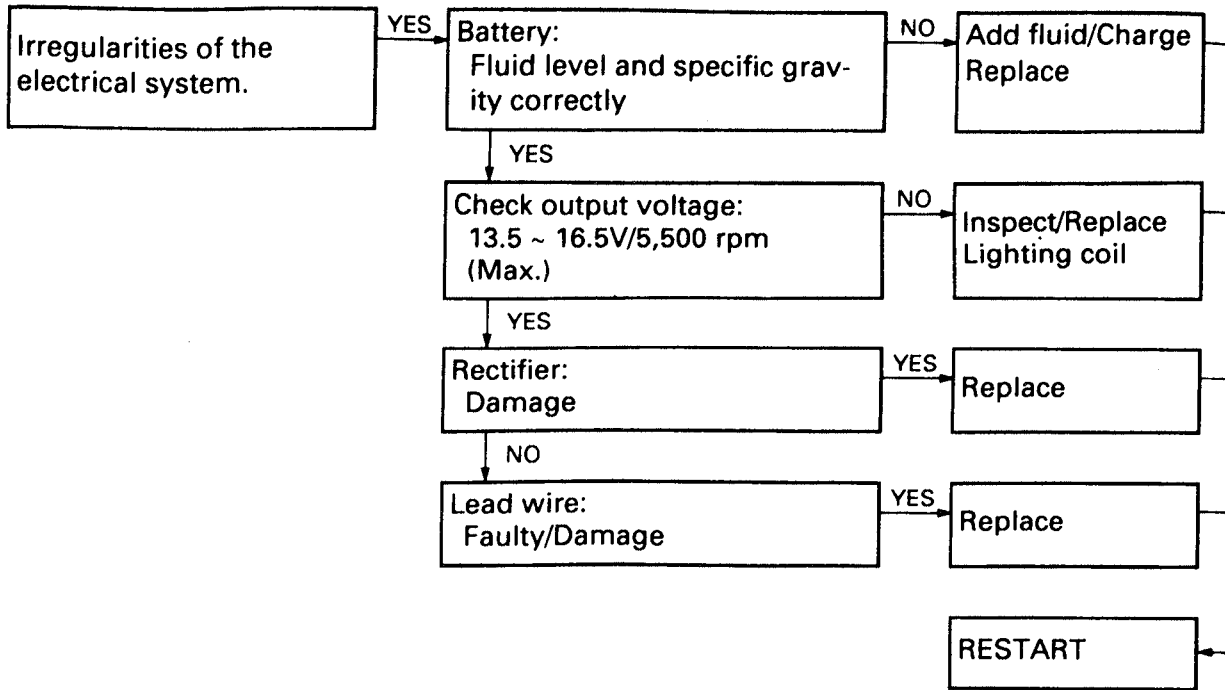

LIBRARY COPY 5/1/2000

**DO NOT REMOVE THIS ITEM FROM  
THE YAMAHA LIBRARY!**

**LIT-18616-01-64**

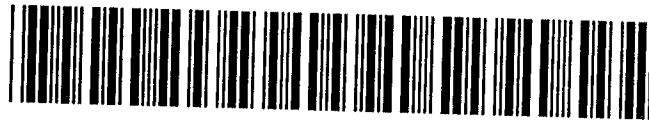

**6V, 8V 1997 Service Manual**

1 PC.

**LIT186160164**

